



Office of Education  
and Data Management

Fall 2017  
Career Development

November

## Testing and Inspection of Plumbing and Mechanical Systems

John Tye, B.O., OSBI, DAS

Use of Office of Education and Data Management (OEDM) training materials must be approved in writing by the State of Connecticut, Department of Administrative Services' Office of Communications.

## “Inspection Procedures”

**The following presentation provides specific information to aide in Plumbing, Mechanical and Gas inspections and testing.**

**The presentation will include structures and systems regulated by the International Residential Code for One and Two Family Homes, International Plumbing Code, International Mechanical Code and National Fuel Gas Code.**

## Inspection Procedures continued

- The intent of the program is to make local Building Officials and Fire Marshals and their employees aware of mandatory code inspection requirements. The hope is that we can get everyone on the same page.
- The following program will reference some of the dos and don'ts when it comes to not only performing the tests correctly but also performing the inspection correctly.

## Inspection Procedures continued

- The following program will also identify some of the tricks portrayed by some of the more questionable contractors and installers. A good contractor who is knowledgeable in his or her field will usually try and perform the installation correctly. He or she may make a mistake (which is why we perform thorough inspections) but basically performs the installation correctly and to code. A contractor who is trying to cut corners will get away with whatever **you allow!** Code requirements are **"MINIMUM"** requirements and **anything less is unacceptable!**

## Inspection Procedures continued

- **The adopted code requires that a list of mandatory inspections be posted in the building department.**
- **International Residential Code Section 109.1.7**
- **International Plumbing Code Section 107.2.6**
- **International Mechanical Code Section 107.2.6**
- **This list should be visible to permit applicants. The more information given to the permit applicant related to required inspections will hopefully eliminate future problems and misunderstandings.**

## Inspection Procedures continued

- **In addition to the list of required inspections the handout may want to include specific testing requirements and prohibited methods of testing such as air testing of plastic and cast iron piping.**
- **All ductwork must be inspected before the installation of duct insulation.**
- **A description of gauge requirements for pressure testing will eliminate problems such as someone using a 100psi gauge for a 5psi test.**
- **A common complaint we receive at OSBI is that the permit applicant was not aware of the required inspections and necessary equipment to perform the inspection.**

### “Submitted plans and specifications”

- The International Residential Code for One and Two Family Dwellings pertains to residential installations. Plans and specifications for electrical, plumbing, hvac, and gas are rarely submitted for residential installations.
- The International Plumbing Code (IPC), International Mechanical Code (IMC), and the National Fuel Gas Code (NFPA 54) pertain to commercial installations. **A good place to start with the inspection and testing requirements is with the approved plans and specifications.** Many times the referenced testing is more stringent than the code required minimum and usually located in the specific piping sections of the approved specifications.

### “Submitted plans and specifications cont.”

- Plan Review (**Commercial Projects**)
- When a thorough plan review is performed code violations can be identified and corrected before the actual installation.
- Waste and vent piping configurations are easier to correct during the plan review stage rather than at the time of inspection. Many installers perform their installations according to the approved plans and specifications and if a permit is granted with code violations which were not identified on these plans it makes for problems in the field.
- Seismic bracing, (**when required**) must be identified on the plans.
- Pipe anchorage and sway bracing locations(**when required**) should also be identified on the plans. These requirements are rarely addressed or included in the installation.\*\*\*

## “Submitted plans and specifications cont.”

- It's the engineer of records job to provide a code compliant design with all necessary details on the drawings. Many of the submitted plans we at OSBI review are incomplete and incorrect. Please be advised that just because a set of drawings contains the engineer of record's stamp does not mean they are code compliant. Correctly drawn plans with adequate details included, makes our job easier when performing the inspections. \* **Our job is not to design or tell the installer how to perform the installation.** Our job is to make sure the installation is performed according to the approved plans and specifications which are supposed to be code compliant. **The approved plans and specifications are the code!**

## “Inspection Procedures cont.”

Specific code sections related to inspection and testing:  
International Plumbing Code (IPC) and the International  
Mechanical Code (IMC) **(Commercial installations)**

1. Section 107 Inspections and Testing
2. Section 107.1 General
3. Section 107.2 Required inspections and testing
4. Section 107.2.6 Posting of required inspections
5. Section 107.7 Notification of inspection and testing results

## “Plumbing Inspection Procedures”

- **Rough Inspection “Plumbing systems”**
- **Preconcealment - The following parts of the plumbing system require inspections prior to the installation of the actual plumbing fixtures.**
- **Outside the structure**
- **Water service inspection (unless by utility company)\***
- **Building sewer inspection (unless by utility company)\***
- **Storm drainage system (outside structure)**
- **Inside the structure**
- **Drainage waste and vent system (could include acid waste systems etc.)**
- **Storm drainage system**
- **Water distribution inspection**

## “Underground outside plumbing and storm cont.”

- **Outside storm water piping** usually pertains to projects larger than one and two family dwellings.
- The installation requirements are usually specified in the approved plans and specifications. The pipe bedding requirements are usually located in an installation detail.
- The pitch of the outside storm piping is usually specified in the approved plans and specifications.
- Storm piping usually has no test requirements when located **outside** the structure.

**continued**

## “Underground DWV and Storm outside building.”

- **DWV** piping located outside the building contains many of the same requirements as piping installed inside the foundation.
- The code contains bedding requirements and on plan and spec projects requirements are usually located on an installation detail located in the approved construction documents.
- The pitch requirements are also found in the code and also in the approved construction documents.
- When installed with the building water main the installation must comply with IPC Section 603.2 **Separation of water service and building sewer.**

continued

## “Underground DWV pipe outside foundation”

- The materials used for outside the foundation can come from the **IPC Table 702.3 Building Sewer Pipe** which allows such piping as SDR35 (PVC) which is not allowed within the building foundation.
- The materials found in IPC Table **702.2 Underground Building Drainage and Vent Pipe** can be used inside or outside the foundation. If the materials found in Table 702.2 are used clearances to water mains required in IPC Section 603.2 are eliminated and the piping could actually be located in the same trench.
- Unlike the outside storm water piping the outside sewer piping is required to be tested.

## “Rough plumbing underground DWV and Storm piping inside the building foundation.”

- **“Proper pipe bedding”\*\*\***
- Was a plan and set of specifications submitted for the project? If a plan and specification was submitted was an installation detail provided for the installation of underground piping?  
**Details provided are usually very specific and must be followed.**
- All installed piping must be properly supported. The code requires solid and continuous load-bearing support shall be provided. If the observed piping elevation is deep the underground may have to be installed and tested in stages to achieve proper piping support and ultimately code compliance.\*\*\*
- **“Check piping layout”**
- Check for correct material, fittings and piping configurations. IPC Table 706.3 **(Plan Review)** \*
- Some materials are only good for outside the structure such as **SDR35** piping for sewer work which cannot be installed inside the structure or foundation.
- Problems such as flat dry venting below the fixture flood rim, missing code required cleanouts, and exceeding fixture outlet to trap weir distance are often encountered.
- Check for correct method of material joining. IPC Sec. 705

continued

## “Underground inside plumbing and storm cont.”

- Confirm the correct code required pitch. **(based on pipe size) \*\*\***
- Observe “test tees” **(not required by code)** Test tees are usually installed to enable the installer to test the piping in sections but still effectively test all joints. If the installer has not installed test tees have them explain how all joints will be tested. \*
- Once the above items have been confirmed the ten foot head of water test is ready to be observed. It appears many of the installers are performing the ten foot head test incorrectly. The ten foot is measured from the water level being observed down ten feet. Only piping and fittings located below this level are under test. \*
- **THE WATER LEVEL MUST NOT DROP WHILE TEST IS BEING PERFORMED!!! NO EXCEPTIONS!!! \*\*\***



## “Underground plumbing and storm piping cont.”

- **IPC Section 306 Trenching, Excavation and Backfill**
- **306.1 Support of piping** The piping must be supported throughout its entire length!
- **306.2 Trenching and bedding** Solid and load bearing support required. Bell and coupling holes may be provided to accommodate the joining of the pipes. Piping **SHALL NOT** be supported on blocks to grade. A common unacceptable practice is to support piping on small piles of sand etc. \*\*\*

## “Trenching and pipe bedding”



### Specified bedding!



### Incorrect pipe bedding.





### Incorrect pipe bedding.



### Improper pipe bedding!



## Examples of properly bedded piping and test tees.

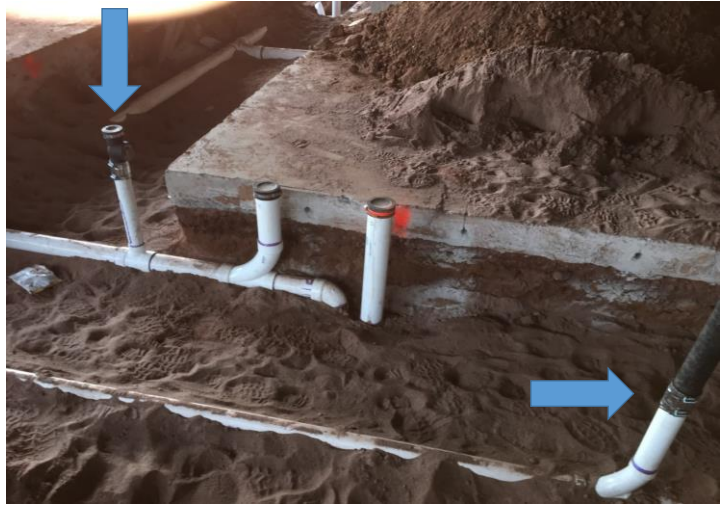

## Improperly bedded piping! Should be two stage!

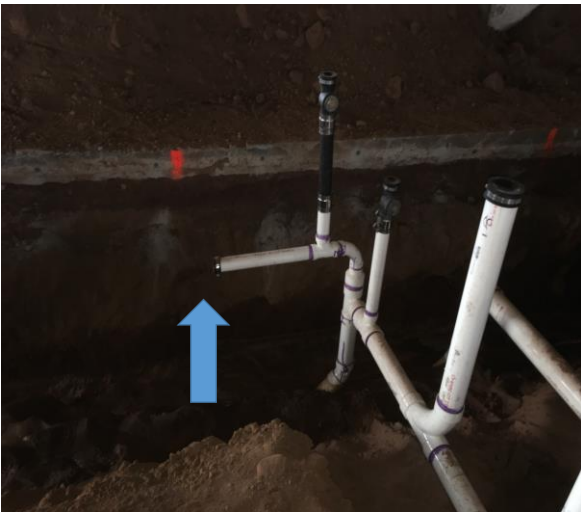



## Improperly bedded piping!



## Improper pipe bedding



## Backfill problems with flowable fill



## Incorrect bedding!





## “Plumbing and storm piping cont.”

- **Section 306.2 continued**
- **Please be advised that in some cases the material manufacturer has more stringent requirements than the code and must be followed. Manufacturers such as Charlotte Pipe have their own piping installation manual which contains many specific requirements which are not addressed in the code. \*\*\***

## “Plumbing and storm inspections cont.”

- **IPC Section 306.2.1 Overexcavation**
- **Overexcavation is a common problem and if not addressed results in serious problems with the finished plumbing system. \*\*\***
- **The code requires the overexcavated part of the trench to be backfilled with sand or fine gravel placed in layers not greater than 6 inches in depth and such backfill shall be compacted after each placement. **Please be advised that it doesn't take much bedding instability to affect minimum piping pitch requirements of 1/8<sup>th</sup> and 1/4 inch per foot.****

## “Plumbing and storm inspections cont.”

- **IPC Section 306.2.2 Rock removal.** Where rock is encountered in the trenching, the rock shall be removed to not less than three inches below the installation level of the bottom of the pipe. The trench shall be backfilled with sand and tamped.
- **IPC Section 306.2.3 Soft load-bearing materials.** Stabilization shall be achieved by overexcavating not less than two pipe diameters and backfilling to installation level of the bottom of the pipe with fine gravel, crushed stone or a concrete foundation.

## “Plumbing and storm piping cont.”

- **IPC Section 306.3 Backfilling**
- **Shall be free from discarded construction materials and debris.** Loose earth free from rocks, broken concrete, and frozen chunks shall be placed in the trench in six inch layers and tamped in place until the crown of the pipe is covered by twelve inches of tamped earth. The backfill under and beside the pipe shall be compacted for pipe support. Backfill shall be brought up evenly on both sides of the pipe so pipe remains aligned. Many times piping manufacturer’s and job specifications have stricter requirements than code minimums.



## “Plumbing and storm piping cont.”

- **“Backfilling continued”**
- **Correct bedding and backfilling are extremely important. If the piping is installed on unstable or unsuitable material the problems will only be compounded when backfilling takes place. As referenced in the previous slide #21 the piping has minimum pitch and it doesn't take much to cause the incorrectly bedded piping to become flat or reverse pitched. If the underground piping is incorrectly installed the whole plumbing system will be compromised.**

## “Plumbing and storm piping cont.”

- **IPC Section 306.4 Tunneling.**
- **Where pipe is to be installed by tunneling, jacking or a combination of both, the pipe shall be protected from damage during installation and from subsequent uneven loading. Where earth tunnels are used, adequate supporting structures shall be provided to prevent future or caving.**

## “Plumbing and storm piping cont.”

- **IPC Section 307 Structural Safety**
- **Section 307.1 General**
- **While performing plumbing installations any part of the building that must be changed or replaced shall be left in a safe structural condition according to the requirements of the International Building Code.**
- **Section 307.2 Cutting, notching or bored holes. \***

## “Plumbing and storm piping cont.”

- **Installations and alterations resulting in additional structural loads to any member (HVAC equipment etc.) shall not be permitted without verification that the truss is capable of supporting the additional load.**
- **A good example would be the addition of an air handler in the attic which is supported from the truss.**

### **“Plumbing and storm piping cont.”**

- **Section 307.3 Penetrations or floor/ceiling assemblies and fire resistant-rated assemblies.**
- **Penetrations of floor/ceiling assemblies and assemblies required to have a fire-resistance rating shall be protected in accordance with the IBC.**
- **Section 307.4 Alterations to trusses.**
- **Truss members and components shall not be cut, drilled, notched, spliced or otherwise altered in any way without written concurrence and approval of a registered design professional. \*\*\***

### **“Plumbing and storm piping cont.”**

- **IPC Section 307.5 Trench location.**
- **Trenches installed parallel to footings shall not extend below the 45 degree bearing plane of the footing or wall.**
- **IPC Section 307.6 Piping materials exposed within plenums.**
- **All piping materials exposed within plenums shall comply with the provisions of the International Mechanical Code.**

## “Plumbing and storm piping cont.”

- **IPC Section 308 Piping Support.**
- **Section 308.1 General.**
- **All plumbing piping shall be supported in accordance with this section.**
- **Section 308.2 Piping seismic supports.**
- **Where earthquake loads are applicable in accordance with the building code, plumbing piping supports shall be designed and installed for the seismic forces in accordance with the International Building Code.**

## “Plumbing and storm piping cont.”

- **Section 308.3 Materials.**
- **Hangers, anchors and supports shall support the piping and the contents of the piping. Hangers and strapping material shall be of approved material that will not promote galvanic action. \*\*\***
- **Section 308.4 Structural attachment.**
- **Hangers and anchors shall be attached to the building construction in an approved manner.**
- **Piping cannot be supported from other piping. \***

## “Plumbing and storm piping cont.”

- **Section 308.5 Interval of support.**
- **Pipe shall be supported in accordance with Table 308.5.**
- **Exception: The interval of support for piping systems designed to provide for expansion/contraction shall conform to the engineered design in accordance with section 316.1.**
- **Many pipe manufacturers have more stringent requirements which govern the installation. In some cases the manufacturers have less stringent requirements such as the maximum distance between hangers. In this case the more stringent requirement (code) would apply.**

## “Plumbing and storm piping cont.”

- **Section 308.6 Sway bracing\*\*\* Usually not addressed by the designer, performed by the installer or identified by the inspector.**
- **Rigid sway bracing shall be provided at changes in direction greater than 45 degrees for pipe sizes 4 inches and larger.**
- **This section contains lateral support requirements for pipe 4” and larger in diameter. The flow of waste in the drainage piping subjects the piping to the forces that result from the momentum of the waste.**
- **These products are a product of the mass and velocity of the flow together with the change in direction of the pipe and can be quite large, especially in piping 4” and larger. Without adequate bracing, the piping could be damaged or joint failure could occur.**

## “Examples of sway bracing and anchorage”

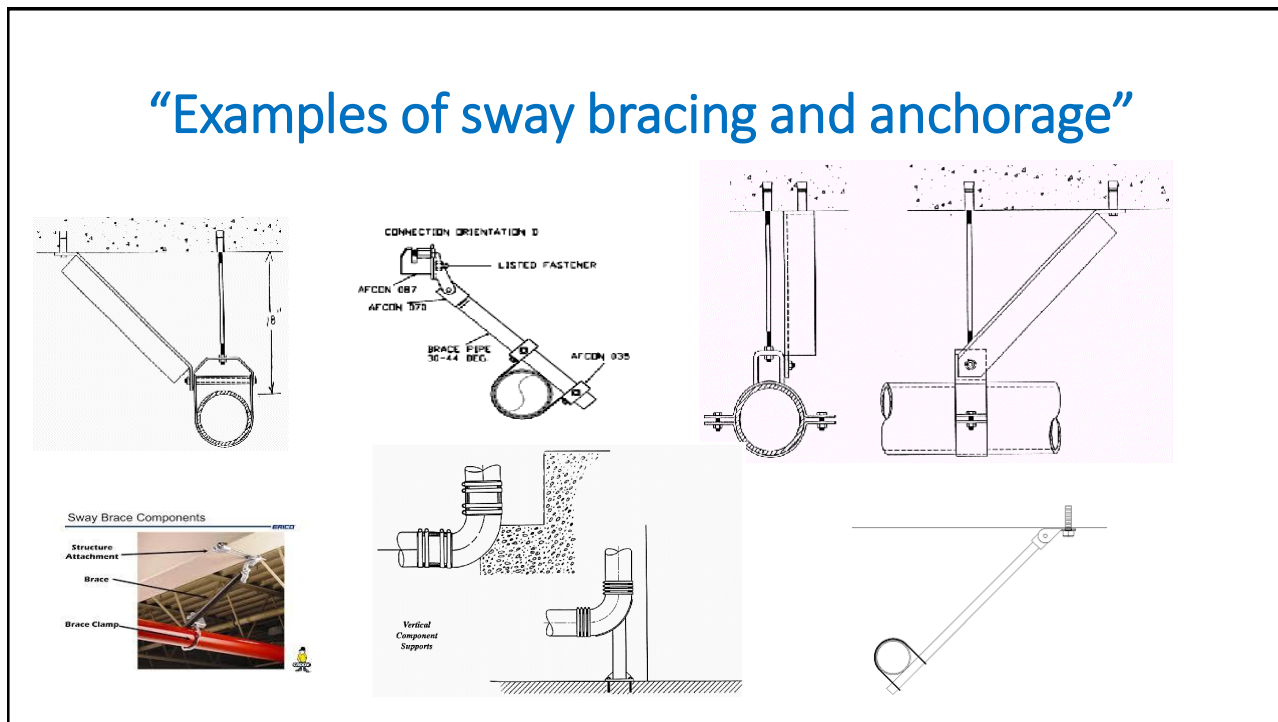

## “Plumbing and storm piping cont.”

- **Section 308.7 Anchorage.**\*\*\* **Same issues as Sway bracing!**
- Anchorage shall be provided to restrain drainage piping from axial movement.
- **Section 308.7.1 Location.**
- **For pipe sizes greater than four inches**, restraints shall be provided for drain pipes at all changes in direction and at all changes in diameter greater than two pipe sizes. Braces, blocks, rodding and other suitable methods as specified by the coupling manufacturer shall be utilized.

# “Examples of sway bracing and anchorage”

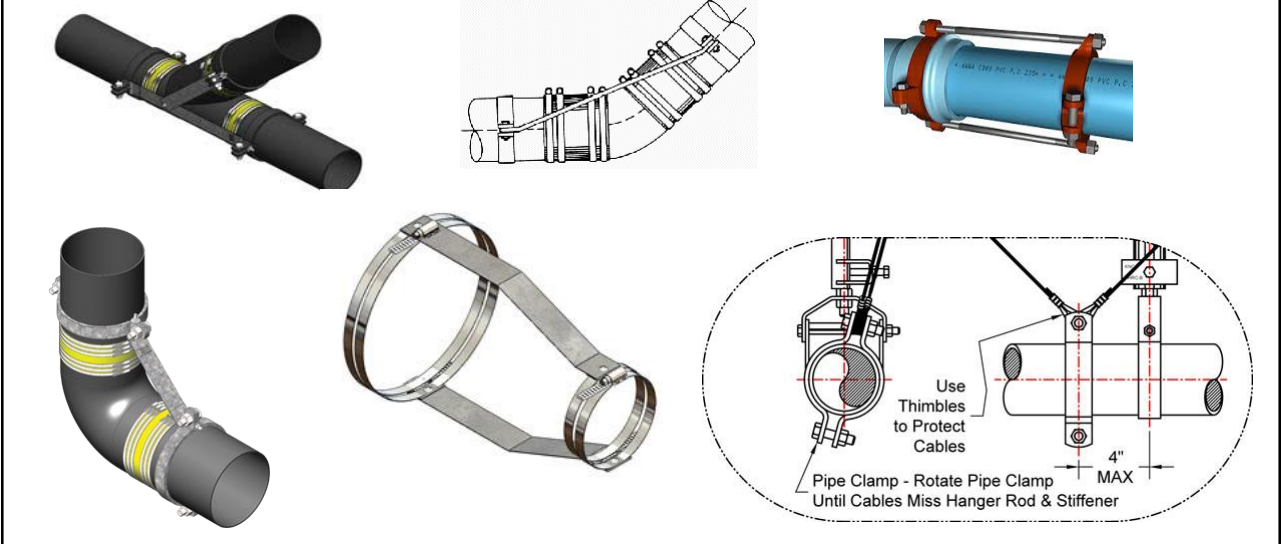

# “Examples of sway bracing and anchorage”

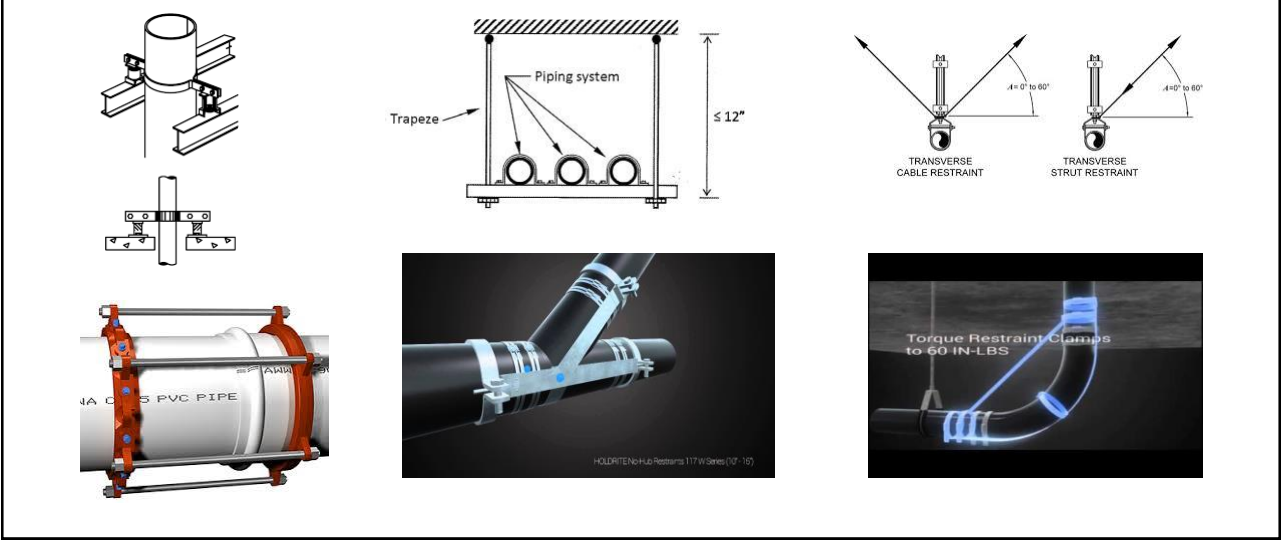

## “Plumbing and storm piping cont.”

- **Section 312 Tests and Inspections**
- **Section 312.1 Required tests**
- The permit holder is responsible for
- All tests to be performed
- Notice to the code official\*\*\*
- All equipment, materials, power and necessary labor to perform the required tests.
- **ALL PIPING MUST BE TESTED!!!!**

## “Plumbing and storm piping cont.”

- **Section 312.1 continued**
- **IMPORTANT!!!!** The section contains a reference that **ALL** plumbing system piping shall be tested with either water or for piping systems **other than plastic** by air. **AIR TESTING IS NOT PERMITTED ON PLASTIC AND CAST IRON PIPING.** The code is silent about air testing cast iron. **The piping manufacturer of the cast iron piping prohibits testing with air!** The section also references a final plumbing test after fixtures have been installed.\*\*\*



## “Plumbing and storm piping cont.”

- **Section 312.1.1 Test gauges.**
- **Gauges used for testing shall be as follows:\*\*\***
  - **1. Tests requiring a pressure of 10 psi or less shall utilize a testing gauge having increments of 0.10 psi or less.**
  - **2. Tests requiring a pressure of greater than 10 psi but less than or equal to 100psi shall utilize a testing gauge having increments of 1 psi or less.**
  - **3. Tests requiring a pressure greater than 100 psi shall utilize a testing gauge having increments of 2 psi or less.**

## “Plumbing and storm piping cont.”

- **Section 312.2 Drainage and vent water test.**
- **A water test shall be applied to the drainage system in its entirety or in sections. Test tees are usually installed when performing sectional testing. If the test tee is correctly configured the tests can be continued without retesting previously tested piping. \* Without some type of test tee the entire system may have to be retested to confirm all joints are leak free.**

## Test tee installation examples

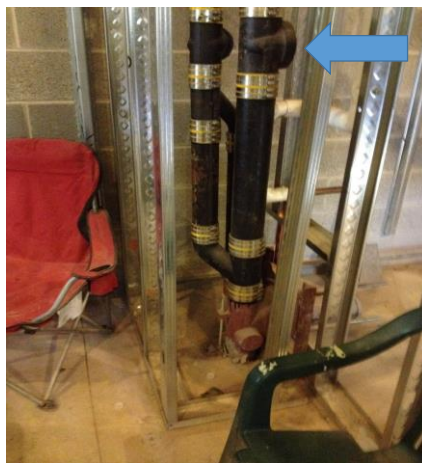

## “Plumbing and storm piping continued”

- **Section 312.8 Storm Drainage System Test.**
- **Storm drain systems within the building shall be tested by water or air in accordance with Section 312.2 and 312.3.**
- **Storm drain piping is usually tested the same as waste and vent piping. Test tees are usually employed and a ten foot head of water is customarily utilized. The upper ten feet of piping is treated the same as sanitary waste and vent and the piping will only be tested up to the roof drain.\*\*\* A ten foot head test is not required on the roof drain. The area around the roof drain should be flooded to confirm the drain connection to the roofing membrane.**

### “Plumbing and storm piping cont.”

- Section 312.3 Drainage and vent air test.
- Plastic piping **shall not** be tested using air. \*
- Although the code does not prohibit cast iron pipe from being tested with air the pipe manufacturer’s prohibit testing with air.\*
- Air testing is limited to galvanized piping, copper tubing, stainless steel and other approved materials other than plastic or cast iron.
- A steady gauge pressure of 5psi is required by code. The test must hold for a minimum of 15 minutes.

continued

### “Plumbing and storm piping cont.”

- Air tests are easy to apply; however, there are disadvantages to air testing. Defects are harder to locate when using air. System temperature changes can produce misleading changes in pressure which may be interpreted as a leak.\*\*\*
- Testing with a compressed gas (air) is inherently more hazardous to personnel than water testing because of the energy release that can occur from a system rupture or failure. The 5 psi testing pressure is often exceeded in the field to locate leaks easier. Increasing the test pressure beyond the safe limits of the material can result in a dangerous situation and must not be allowed.

## “Plumbing inspections cont.”

- **Section 312.4 Drainage and vent final test.\*\*\***
- **The final test of the completed drainage and vent systems shall be visual and in sufficient detail to determine compliance with the provisions of this code. Where a smoke test is utilized, it shall be made by filling all traps with water and then introducing into the entire system a pungent, thick smoke produced by one or more smoke machines. When the smoke appears at stack openings on the roof, the stack openings shall be closed and a pressure equivalent to a 1” water column shall be held for a test period of not less than 15 minutes. \*\*\***

## “Air admittance valves”



# “Typical testing materials and equipment”



# “Plumbing inspection cont.”

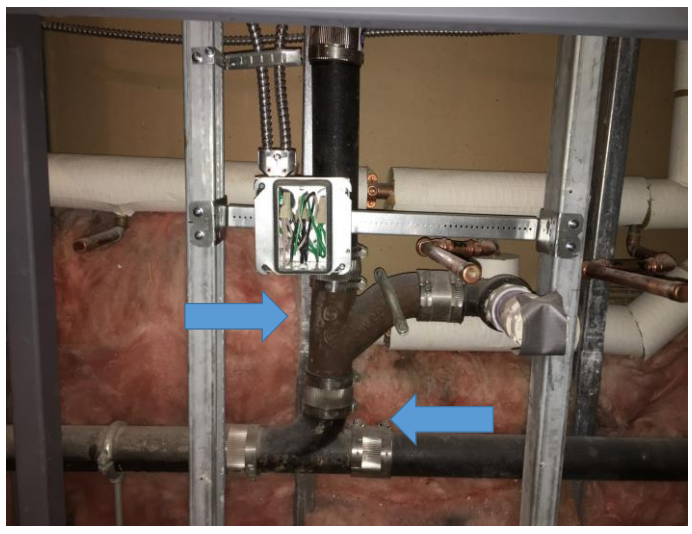
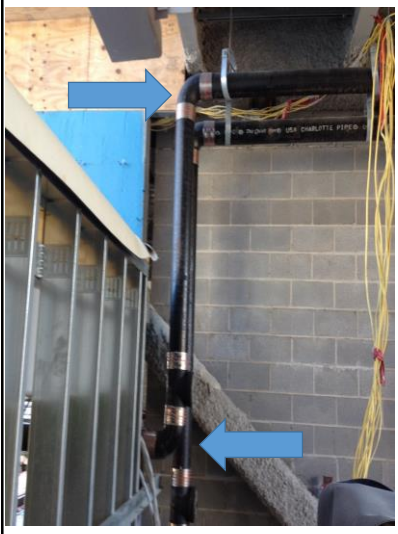



### Plumbing inspections cont.

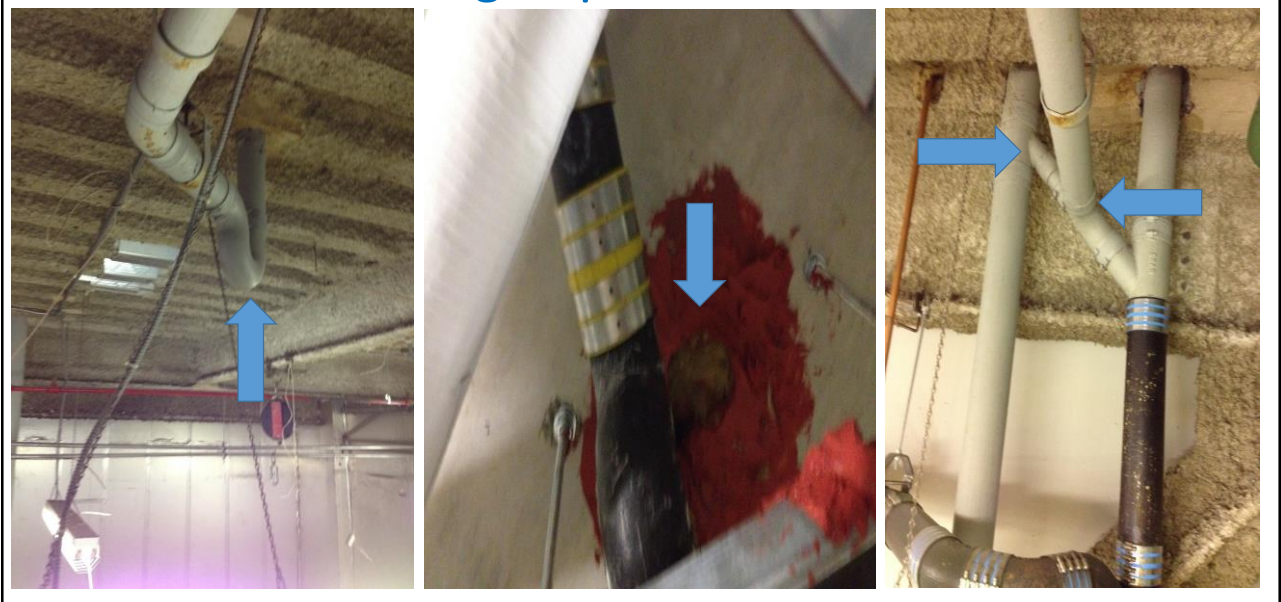

### “Plumbing and storm piping inspections cont.”

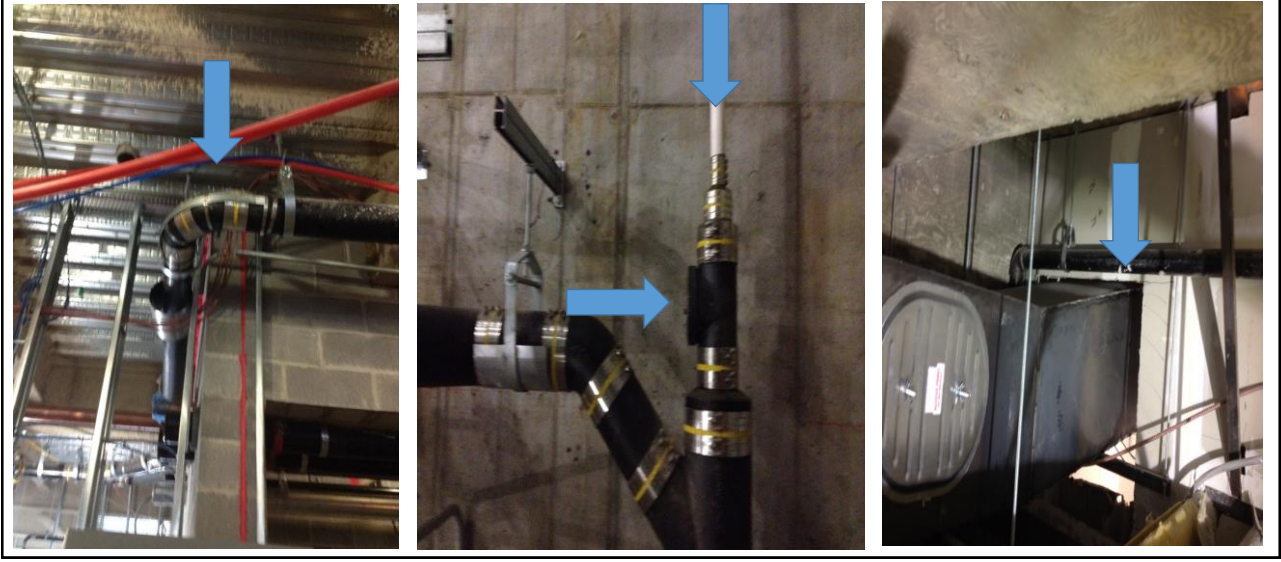

### “Plumbing inspection problems”



### “Plumbing inspection problems”





## “Plumbing inspection problems”



## “Mechanical Code Inspections”

- The Mechanical Code has inspection requirements similar to the International Plumbing Code.
- **Section 107.2 Required Inspections and Testing**
- Underground inspections
- Rough-in inspections
- Final inspections upon completion
- **Section 302 Protection of Structure**
- This section references proper cutting, notching and boring in all types of structural materials.



## Mechanical Code Inspections continued.

- The mechanical code includes additional sections related to cutting and notching not found in the plumbing code. These specific requirements will be referenced when performing the rough and in some cases the final inspections of mechanical equipment and piping.
- **Section 303 Equipment and Appliance Location**
- These sections are referenced when performing new appliance and equipment inspections. Many times the installer does not follow the manufacturer's installation instructions and in some cases the equipment is incorrectly located and the requested inspection may need to be aborted. **Make sure the equipment is properly located before proceeding with the inspection!**

## Mechanical Code Inspections continued.

- **Section 304 Installation**
- This section of the code states equipment and appliances shall be installed as required by the terms of their approval, in accordance with the conditions of the listing, the manufacturer's installation instructions and this code. Manufacturer's installation instructions shall be available on the job site at the time of inspection! **You can't perform a proper inspection without the installation instructions!**
- **Section 304.3 Elevation of ignition source.**
- Equipment and appliances having an ignition source and located in hazardous location and public garages, private garages, repair garages, automotive motor fuel-dispensing facilities and parking garages shall be elevated such that the source of ignition is not less than 18 inches above the floor surface on which the equipment or appliance rests.

## **Mechanical Code Inspections continued.**

- **Section 304.9 Clearances to combustible construction.**
- **Heat producing equipment and appliances shall be installed to maintain the required clearances to combustible construction as specified in the listing and the manufacturer's instructions. Such clearances shall be reduced only in accordance with Section 308. Clearances to combustibles shall include such considerations as door swing, drawer pull, overhead projections or shelving and window swing, shutters, coverings and drapes. Devices such as doorstops or limits, closers, drapery ties or guards shall not be used to provide the required clearances.**

## **Mechanical Code Inspections continued.**

- **Section 304.10 Clearances from grade.**
- **Equipment and appliances installed at grade level shall be supported on a level concrete slab or other approved material extending not less than 3 inches above adjoining grade or shall be extended not less than 6 inches above adjoining grade. Such support shall be in accordance with the manufacturer's installation instructions.**
- **Section 304.11 Guards.**
- **Guards shall be provided where appliances, equipment, fans or other components that require service and roof**

## **Mechanical Code Inspections continued.**

**hatch openings are located within 10 feet of a roof edge or open side of a walking surface and such edge or open side is located more than 30 inches above the floor, roof or grade below.**

- **Section 304.12 Area served.**
- **Appliances serving different areas of a building other than where they are installed shall be permanently marked in an approved manner that uniquely identifies the appliance and the area it serves.**

## **Mechanical Code Inspections continued.**

- **Section 305 Piping Support**
- **Section 305.2 Materials.**
- **Pipe hangers and supports shall have sufficient strength to withstand all anticipated static and specified dynamic loading conditions associated with the intended use. Pipe hangers and supports that are in direct contact with piping shall be of approved materials that are compatible with the piping and that will not promote galvanic action.**
- **Section 305.4 Interval of support.**
- **Piping shall be supported at distances not exceeding the spacing specified in Table 305.4, or in accordance with MSS SP-69.**

## **Mechanical Code Inspections continued.**

- **Section 305.5 Protection against physical damage.**
- **Shield plates if piping other than cast-iron or steel are located within 1 ½” from the nearest edge of the member. The shield plates should be 16 gage and extend a minimum of 2” above the sole plates and below top plates.**
- **Section 306 Access and Service Space.**
- **Section 306.1 Access for maintenance and replacement.**
- **Appliances shall be accessible for inspection, service, repair and replacement without disabling the function of a fire- resistant-rated assembly or removing permanent construction, other**

## **Mechanical Code Inspections continued.**

**appliances, venting systems or any other piping or ducts not connected to the appliance being inspected, serviced, repaired or replaced. A level working space at least 30 inches deep and 30 inches wide shall be provided in front of the control side to service an appliance.**

- **Section 306.1.1 Central furnaces.**
- **Section 306.2 Appliances in rooms.**
- **Section 306.3 Appliances in attics.**
- **Section 306.4 Appliances under floors.**

## Mechanical Code Inspections continued.

- **Section 306.5 Equipment and appliances on roofs or elevated structures.**
- **Section 306.5.1 Sloped roofs**
- **Section 307 Condensate Disposal**
- **Section 307.1 Fuel-burning appliances.**
- **Section 307.2 Evaporators and cooling coils.**
- **Section 307.2.1 Condensate disposal.**
- **Section 307.2.2 Drain pipe materials and sizes.**
- **Section 307.2.3 Auxiliary and secondary drain systems.**

## “Kitchen Exhaust Equipment Inspections”

- **The following slides relate to required inspections performed on installed kitchen exhaust systems.**
- **Problem areas will be identified as we progress through these slides.**
- **The International Mechanical Code (IMC) applies to new construction.**

## “Kitchen Exhaust Inspections continued”

- **Chapter 5 of the International Mechanical Code**
- **A complete plan must be submitted for the entire exhaust installation including the hood, ductwork, mechanical equipment such as upblast fan, in-line fan, make-up air unit or other equipment.**
- **Hood suppression system based on equipment located under the hood. (Actual equipment observed during inspection must be confirmed with the submitted approved plan.) Many times the equipment has been changed and improperly placed under the hood.**

## “Kitchen Exhaust Inspections continued”

- **Manufacturers installation instructions for the hood.**
- **Is the hood listed and labeled? \*Many times hoods are not listed and labeled and in some cases the label on the hood does not pertain to the actual hood, such as a hood that might reference zero clearance when it actually requires 18” to combustibles. Extremely important to check the manufacturer’s instructions.**
- **Kitchen hood supports. Most manufacturers require threaded rod supports. Mounting brackets for the threaded rod are usually part of the hood construction.**

## “Kitchen Exhaust Inspections continued”

- Many times installers are trying to hang or support the hood with chain. **(Chinese restaurants) (This is not an approved method.)**
- Clearance to combustibles = **18”** from all parts of the Type 1 Hood, top, sides, back and bottom.
- **IMPORTANT** Wall construction behind hood.
- Combustibles are not permitted to be located within the wall construction of the back wall. Insulation (kraft paper), piping such as PVC are just a few of the materials not permitted in the back wall.
- **\* Many times the installer and the inspector forget about the exposed wall above the hood and behind the hood.**
- **OUT OF SIGHT OUT OF MIND!!!!**

## “Kitchen Exhaust Inspections continued”

- Kitchen exhaust duct construction for type 1 hoods
- Black iron, stainless steel, and factory made grease duct.
- Steel minimum 16 gage
- Stainless steel minimum 18 gage
- Factory-built listed and labeled in accordance with UL 1978.  
**The problem with factory-built duct is nobody asks for and reviews the manufacturer’s installation instructions. Each manufacturer has different requirements. In some cases the installer has tried to substitute factory-built boiler flue for factory built grease duct!**

## “Kitchen Exhaust Inspection continued”

- Another common problem is the duct installer connecting **class one flexible ductwork** to the make-up air plenum above a Type 1 hood. This flexible duct is considered a combustible and must not be located within 18” of the Type 1 hood.
- Duct joint types
- Butt joints, welded flanged joints, overlapping, such as telescoping or bell.
- **Problems sealing the corners with butt joints.**
- **Problems with “bird mouths” on flanged joints.**

## “Kitchen Exhaust Inspections continued”

- **Flanged joints also are problems at the corners.** Many times in the field we find rather large holes at these locations.
- Duct-to-hood joints welded, brazed, bolted with an approved gasket material.
- Problems with corners when brazing or welding.
- Problems with gasket materials. Installers substitute listed materials for materials such as silicone or general purpose caulk. **The AHJ must require proper documentation to validate the product being used!**



## “Kitchen Exhaust Inspections continued”

- Grease duct testing
- Prior to the adoption of the 2012 International Mechanical Code testing was performed many different ways. The code was not specific. Many of the local jurisdictions used IMC Section 102.9, Requirements not covered by this code.
- Most of the tests, including OSBI’s were performed using smoke. When this test was properly performed the smallest hole or defect were revealed. The current code requires a light test. We actually performed a light test according to the code on ductwork

(continued)

## “Kitchen Exhaust Inspections continued”

- which was put together but not yet welded. The light test did not identify the incomplete joints! \*\*\*
- Many times the required testing must be performed in sections for a proper installation.\*\*\*
- Roof penetrations of the kitchen exhaust duct through the curb are a major concern.
- Steel and stainless steel require 18” clearance to combustibles. The curb and other roofing materials many times contain combustibles. In order to gain code compliance the duct is wrapped with a listed material.

## “Kitchen Exhaust Inspections continued”

- The grease duct penetration through the curb to the upblast fan must be tested and wrapped before installation.
- The amount of space between the roof deck penetration and the grease duct is minimal and the rated wrap goes on in two layers which must be properly banded. **(manufacturer’s installation instructions.)** The wrap must extend inside the curb to the bottom side of the termination to achieve code compliance. The limited space in the cavity would not permit the installer to properly wrap (two layers) and band the wrap.

(continued)

## “Kitchen Exhaust Inspections continued”

- Even if the wrap could be correctly installed it would be impossible for the fire marshal or building inspector to physically observe the installation. Please be aware that this wrap is very heavy and tough to work with, especially in a confined space.
- To properly install the duct penetration through the roof and curb The drop piece should extend below the roof deck at least 18”, if possible. A test must then be performed on the drop piece to confirm no leakage. Once the test has been successfully performed the drop piece can now be insulated.

(continued)

## “Kitchen Exhaust Inspections continued”

- The listed grease wrap can now be properly applied and banded without installation or inspection issues.
- Once the insulation is complete and inspected the assembly can now be lowered into place in the curb and the exhaust duct installation can be continued.
- The grease duct system is required to be pitched back to the hood or a low point known as a **grease reservoir**.
- Common problems in the field are incorrectly pitched ducts, flat or level ductwork and pocketed sections.

## “Kitchen Exhaust Inspections continued”

- Required pitch -Slope not less than one fourth unit vertical in 12 units horizontal (2-percent slope) toward the hood or toward a grease reservoir designed and installed in accordance with Section 506.3.7.1.
- Where horizontal ducts exceed 75 feet in length, the slope shall be not less than one unit vertical in 12 units horizontal. (8.3 percent slope) **Explain problems with pitch requirements on runs over 75 feet.**

## “Kitchen Exhaust Inspections continued”

- Prior to the code change which took place 10/16 the pertinent year of the adopted IMC was 2003. The 2003 IMC contained no specific requirements for the proposed grease reservoir. The 2012 IMC contains 7 specific requirements.
- Grease duct cleanouts and openings. The 2012 IMC now contains 7 specific requirements.
- **Common problems with the installation of grease duct cleanouts:**
- Factory cleanout doors which are not listed for grease duct use. (continued)

## “Kitchen Exhaust Inspections continued”

- Many observed installations contain environmental air duct cleanouts which are **not listed for grease duct applications**. It is important to check the equipment documentation to confirm correct listing. Environmental cleanout construction, material gage, and gasket material are just several of the materials that may not stand up to temperatures and conditions in a grease duct system and could seriously compromise the system.
- Access to the installed cleanouts is also a common problem in the field. (continued)

## “Kitchen Exhaust Inspection continued”

- **Underground grease duct installations**
- **A new section of the mechanical code contains eight mandatory requirements.**
- **These systems are very unique and are mainly used in restaurants where island cooking is preferred. The steel grease duct is the same gage but must also be coated to provide protection from corrosion.**

## “Kitchen Exhaust Inspections continued”

- **Once the entire duct system from the exhaust hood outlet to the outside exhaust fan has been completed, including required cleanouts, the system is ready to be light tested.**
- **Once the system has been successfully observed and light tested the duct is now ready for the remainder of the fire wrap to be installed. The wrap must be installed according to the manufacturer’s installation instructions! **Please remember you cannot perform the installation or the inspection without the instructions!!!!** Items such as cleanouts require special attention and detail!**

## **“Kitchen Exhaust Inspections continued”**

### **• Section 507.16 Performance test.**

- Testing of the completed system is required to confirm proper operation before final approval.
- The first test required is a performance test. The performance test includes the determination that the code-required airflow and containment of all cooking vapors will occur.

### **• Section 507.16.1 Capture and containment test.**

- The permit holder shall verify capture and containment performance of the exhaust system. This field test

## **Kitchen Exhaust Inspections continued.**

shall be conducted with all appliances under the hood at operating temperatures, with all sources of outdoor air providing makeup air for the hood operating and with all sources of recirculated air providing conditioning for the space in which the hood is located operating. Capture and containment shall be verified visually by observing smoke or steam produced by actual or simulated cooking, such as with smoke candles, smoke puffers, etc.

## “Fire and Fire/Smoke Damper Inspections”

- The following slides relate to installation problems which were identified on OSBI projects and town assists I have performed.
- These violations and problems will be discussed or identified during the presentation.
- The incorrect installation of Fire Dampers, Smoke Dampers, and F/S damper systems are encountered on a regular basis by OSBI and OSFM.

## “Damper Inspections continued”

- Typical dampers encountered when performing our inspections:
  - “Fire dampers” Static Type - only intended to be able to close when the flow in the system has been stopped by some other means. Dynamic Type – must be able to close while maximum airflow is occurring in the system.
- These damper applications are commonly mixed-up in the field. **A Static Type damper cannot be used in a airflow condition!**

## “Damper Inspections continued”

- Fire dampers, smoke dampers, combination fire/smoke dampers and ceiling radiation dampers located within air distribution and smoke control systems shall be installed according to the **manufacturer’s installation instructions.**
- **Check for UL listings\*\*\*** Fire Dampers – UL 555  
Smoke Dampers – UL555S  
Combination Fire/Smoke – UL555 and UL555S  
Ceiling Radiation Dampers – UL 555C

## “Damper Inspections continued”

- Common violation – “Framing Issues” The intent of the damper is to **maintain the integrity of the penetration.** Many times the installers pay no attention to the installation instructions. The required framing is one of the most important parts of the installation.\* The proposed damper sleeve must be properly anchored to the required framing. Many times the framing is missing and the damper sleeve is installed in sheetrock.



## **“Damper Inspections continued”**

- **Many times the framing required for the damper installation is incorrect and even entirely missing!**
- **The framing is normally not performed by the damper installer. The carpenters and masons are usually responsible for the opening required to accommodate the fire damper sleeves. The required opening cannot be correctly configured without the manufacturer’s installation instructions which can only be supplied by the damper installer. These instructions are usually never provided and annular spaces are usually incorrect!**

## **“Damper Inspections continued”**

- **Damper framing instructions must be provided to the carpenters and masons prior to constructing walls and in some cases floors.**
- **Sheet metal and wood framing can be difficult at best to reconfigure when annular spaces are incorrect. Openings in concrete and cmu walls and floors when done incorrectly are extremely difficult to correct and many times require extensive demolition and reconstruction.**

## **“Damper Inspections continued”**

- **Dampers are proprietary and installation instructions vary somewhat from manufacturer to manufacturer. **Manufacturer’s installation instructions are required for the correct installation and inspection!!!****
- **Once the framing has been confirmed the next important step is the annular space required between the damper sleeve and the required framing.**

## **“Damper Inspections continued”**

- **The annular space is specified by the damper manufacturer and an important part of the installation.**
- **The purpose of the space is to allow the damper sleeve to expand under a high heat or fire condition and prevent the actual damper from racking or binding which would prevent the damper from proper operation.**
- **Once the annular space has been confirmed the installation requires some type of damper sleeve retainage or anchoring. The retaining angles along with the required framing hold the damper and sleeve in place in a fire event and maintain the integrity of the penetration.**

## “Damper Inspections continued”

- The required metal or wood framing must be inspected before the application of sheetrock!
- When dampers are installed in CMU walls the actual CMU wall is the framing and the actual opening in the CMU penetration must be confirmed before the installation of the damper sleeve. **The overall opening must also include the damper manufacturer’s required annular space!**
- Many times these damper sleeves are installed prior to our inspections and the required openings are usually incorrect. In many cases the installer has also installed the retaining angles making a proper inspection impossible.

## “Damper Inspections continued”

- The basic forms of anchorage or retainage are what is referred to as one sided and two sided attachments.
- Not all dampers can be attached by either method. The manufacturer’s installation instructions will specify the method.
- A two sided attachment is currently the most common installation encountered in the field. The related retaining angles are attached to the damper sleeve only on both sides of the rated penetration.
- A one sided attachment is used many times on shaft penetrations which are difficult to perform retainage from inside the shaft. The one sided attachment requires the retaining angle to be anchored to both the damper framing and the sleeve, hence the one sided attachment.

## “Damper Inspections continued”

- The annular spaces must always be inspected before the installation of the required retaining angles!
- Many of the dampers inspected by our offices are factory installed in the damper sleeve and even come with the factory retaining angles!
- The length of the sleeve is also very important. The damper manufacturer has specific requirements for the length of the sleeve beyond the penetration.
- A breakaway joint is required at these locations. The purpose of the breakaway joint is to allow the attached duct work to separate from the damper sleeve in a fire event allowing the damper to remain in the plane of the penetration and maintain the integrity of the penetration.

## “Damper Inspections continued”

- The retaining angles are also a significant part of the installation.
- The angles are always attached to the damper sleeve and in a one-sided installation the angles are also attached to the building structure.
- The screw or fastener pattern is specific to the damper manufacturer.
- The retaining angle width must overlap the required annular space a minimum of one inch. **Many times the installer does not follow the installation requirements for proper fastening and the fasteners are installed in the annular space void and have no anchoring value. Without proper anchoring the damper will not remain in place and the penetration is compromised!**

## “Damper Inspections continued”

- **Testing of the installed dampers.**
- **Proper access is required to all installed dampers. Damper access should be identified when performing a plan review of the proposed installation!** Identification at the review stage eliminates many problems after the unit has been incorrectly installed! Designers try to lay the responsibility on the installer but many times the design does not allow for proper access. Access doors are required to enable inspection and testing. These doors must be large enough to allow physical contact with the damper mechanism. **Many times the access doors are not large enough!**

## “Damper Inspections continued”

- **All dampers must be cycled or tested to confirm proper operation.**
- **PROBLEMS ENCOUNTERED BY OSBI and OSFM:**
- **Screws and fasteners found in damper tracks preventing damper movement.**
- **Dampers incorrectly configured. Vertical to horizontal etc.**
- **Dampers installed in the wrong direction. The damper many times has a directional arrow. Contractors have even removed the sticker and reattached to match their incorrect installation.**

## “Damper Inspections continued”

- Damper vanes were actually missing when performing required testing. Problems such as this were discovered even after the installer claimed the units were pretested!
- Dampers must be reset once tested. Many installers want to reset the damper after the inspection, without the inspector. They usually have a good reason such as the access door (installed) is too small and reset will be difficult at best. **BE SURE TO SEE THE DAMPER PROPERLY RESET!!!**
- F/S dampers also contain a heat sensing device which must also be tested, usually with some type of heat gun. Many times we have found dampers that were not wired and again the installer claimed the dampers were pretested. We have also been given letters from damper manufacturers claiming the units were factory checked and testing is not recommended and may be detrimental. We test all dampers and many times find factory defects!!!

Access to code required duct smoke  
Proper access is a huge problem in the field.





# “Mechanical inspection issues”



# “Rough inspection framing issues”



### Mechanical inspection problems.

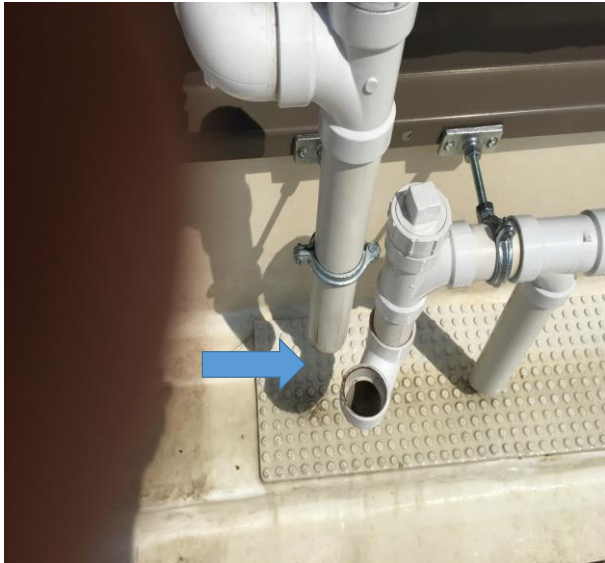

### “Mechanical inspection issues”

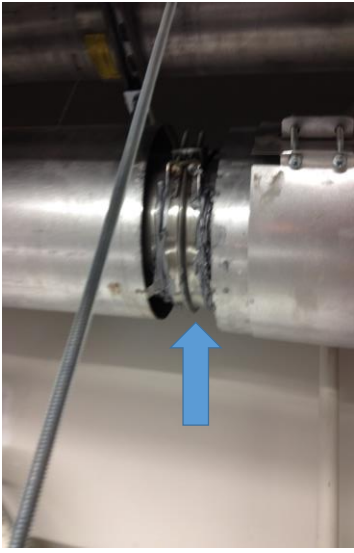



## Direct vent boiler termination “problem”



## Direct vent boiler installation “problem”

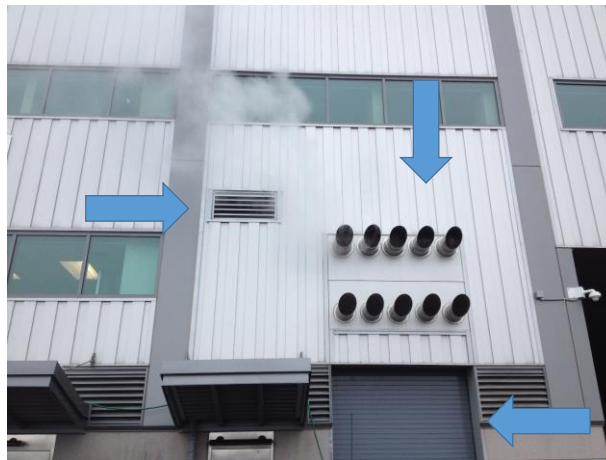

## Direct vent intake and exhaust “problem”



## Direct vent intake and exhaust “problem”



## Direct vent water heater termination “problem”



## Direct vent boiler termination “problem”



## Direct vent boiler termination “problem”



## Direct vent termination “problem”



## Direct vent gas boiler flue connection



## Direct vent flue piping

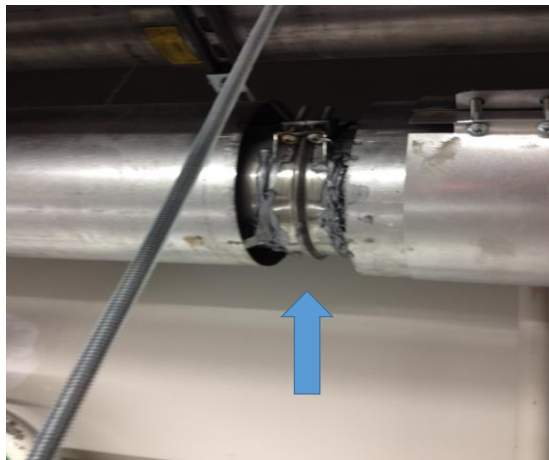



## Direct vent boiler flue connection



## Direct vent gas boiler flue connection

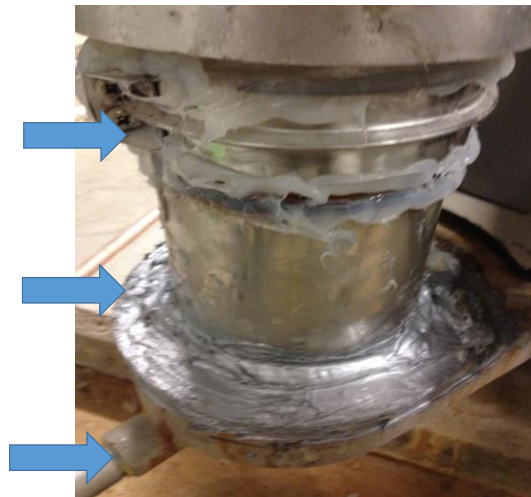

## Condensate drain piping, direct vent water heaters

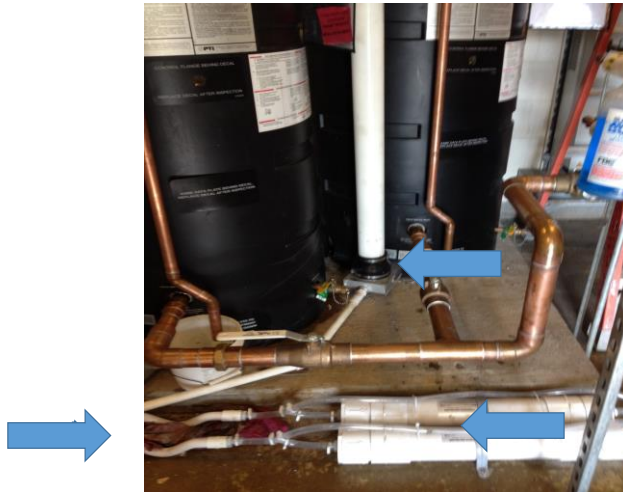

## Gas venting “problems”





## Oil and Gas Equipment Venting

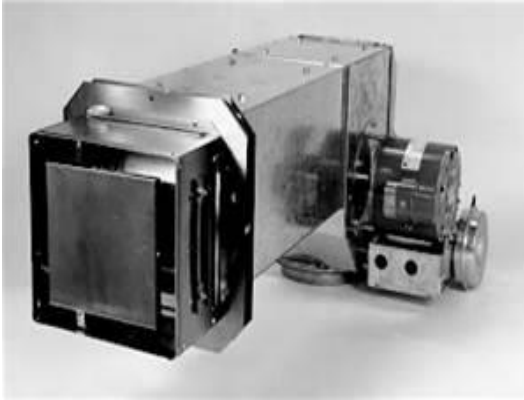

## Gas fired mechanical exhaust

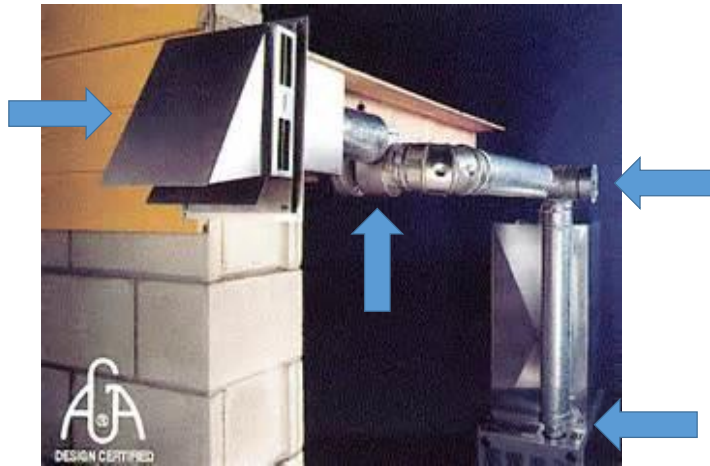

## Combustion Air Fan

This unit is made for gas or oil fired equipment.



Unacceptable service clearance!

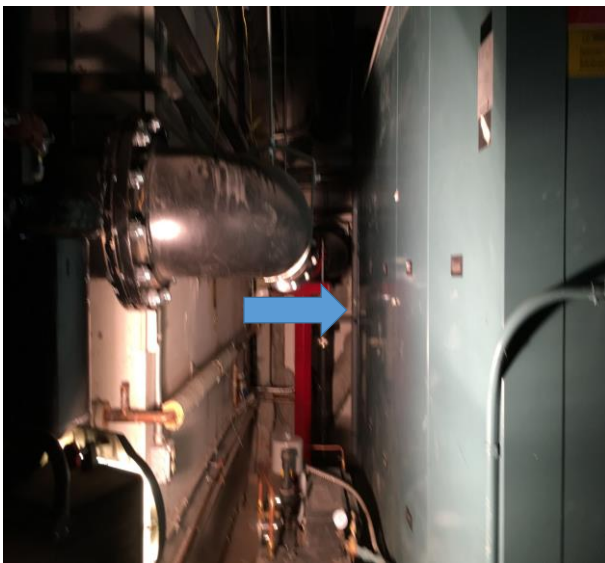

**“Mechanical inspection problems”**

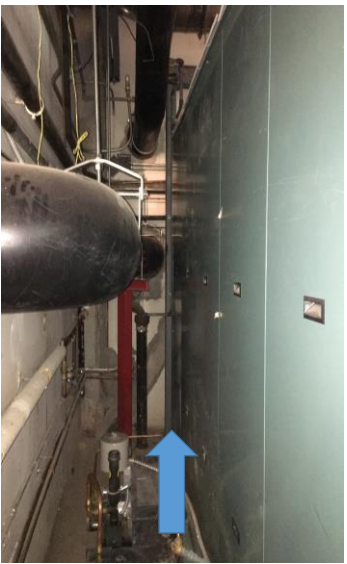

**Unacceptable service clearance!**



# Improper mechanical installations!

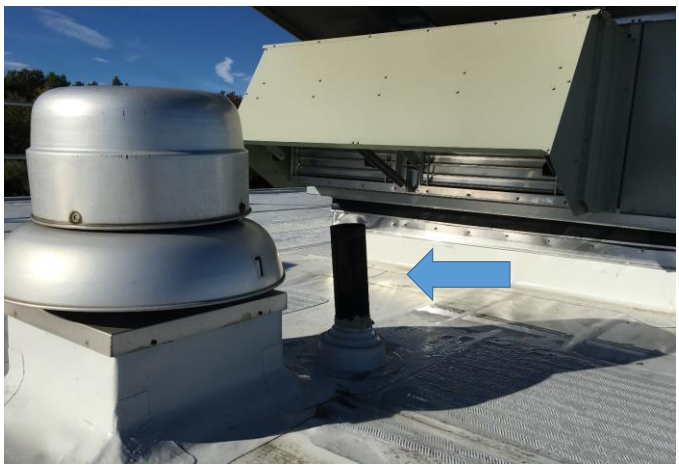

## “Water heater related equipment”

“

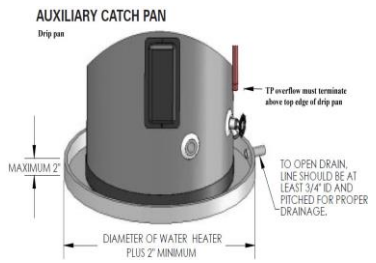



## Incorrect testing methods and materials



## 2012 National Fuel Gas Code

- **The following slides pertain to various types of piping used in gas piping installations and some of the problems encountered during required inspections.**



## “Common Inspection Issues with Gas Installations”

- This next part of the presentation is related to gas piping inspections.
- The 2012 International Residential Code (IRC) contains Chapter 24 for gas related installations and inspections. In addition to Chapter 24 one and two family dwellings will also include the 2012 NFPA 54 document.
- The 2012 NFPA 54 National Fuel Gas Code will be used for all commercial installations.
- Propane gas piping and tank requirements will be found in the 2011 NFPA 58 document for both residential and commercial installations. The IRC has no section for propane tanks and related piping.

## “Common Inspection Issues for gas installations”

- Many of the requirements are the same in both the 2012 IRC Chapter 24 and the 2012 NFPA 54 National Fuel Gas Code.
- Although piping plans are usually not provided for residential installations the code official has the right to ask for a plan of the proposed gas piping installation such as **Section 5.1.1 of the 2012 NFPA 54 document**. Submitted plan and specification projects usually include the gas piping layout which if followed makes inspections easier.
- **A SUBMITTED PLAN ALONG WITH A PROPER REVIEW WILL HELP TO ELIMINATE JOB SITE PROBLEMS!!!! \*\*\***

## 2012 National Fuel Gas Code

### 5.1 Piping Plan:

- **5.1.1 Installation of Piping System.** Where required by the authority having jurisdiction, a piping sketch or plan shall be prepared before proceeding with the installation. The plan shall show the proposed location of piping, the size of different branches, the various load demands, and the location of the point of delivery. A proposed piping plan will aide in the installation and inspection process. Proper sizing will also eliminate future problems such as undersized piping.

### “Gas piping and equipment problems continued”

- Certain fittings such as unions cannot be installed in concealed locations.\*\*\*
- Rough gas piping stub outs **for commercial cooking equipment** are in many cases incorrectly performed. The nipples many times do not extend far enough beyond the finished wall surface (**minimum code requirement**). The piping is usually capped and pressure tested. When these temporary caps are removed for the equipment connection the joints which are concealed in the wall are usually disturbed and in many cases leak. The code requires enough of the nipple to extend beyond the wall surface to allow a wrench to hold the nipple in place and avoid disturbing the concealed joint. **COMMON PROBLEM!**
- Mega-press G has also been approved for gas pipe installations. Manufactured by the same company as Pro-press, Viega. The steel pipe is inserted into the fitting and the fitting is crimped onto the pipe. **The instruction manual is required to perform the inspection!!!**

## 2012 National Fuel Gas Code

- 5.6.2 Metallic Pipe:
- 5.6.3 Metallic Tubing
- **5.6.3.4 Corrugated Stainless Steel.** Corrugated stainless steel tubing shall be listed in accordance with ANSI LC 1/CSA 6.26, *Fuel Gas Piping Systems Using Corrugated Stainless Steel Tubing.*
- *Trac Pipe and Gas Tite are the most common used by licensed installers.*
- *Lowes and Home Depot*

## “Gas piping and equipment problems continued”

- Copper tubing utilized for gas piping (propane or natural) is usually mechanically connected (threaded, flare etc.). Gas piping can be brazed, (not normally performed) **Soldering of the copper is prohibited! \*\*\***
- Copper piping utilizing pro-press type joints. Manufacturer’s installation instructions must be followed!
- Copper piping used in walls etc. should be one piece. When fittings are utilized in these locations they must be approved for concealed locations!
- Steel piping
- Steel is a common material used in the above ground installation of gas piping both propane and natural gas.

## 2012 National Fuel Gas Code

- **5.6.4 Plastic Pipe, Tubing, and Fittings.**
  - **5.6.4.2\* Regulator Vent Piping.** Plastic pipe and fittings used to connect regulator vents to remote vent terminations shall be PVC conforming to **ANSI/UL 651**, *Schedule 40 and 80 Rigid PVC Conduit and Fittings*. PVC vent piping **shall not be installed indoors.**

## “Gas piping and equipment problems” “Underground installations”

- **Materials**
- **Copper**
- **Many contractors bury copper directly in the ground. Copper must be protected from corrosion and physical damage. Burial depths are covered in the code.**
- **Depending on where the second stage regulator is located the code requirements may be NFPA 58 “Propane” or NFPA 54 “National Fuel Gas Code”.**
- **The use of coated copper “jacketed” is customarily used and as long as the run contains no joints the jacketed product meets the intent of the code. **Extremely Important Check the newly installed line in its entire length!****

## 2012 National Fuel Gas Code

### 5.6.5 Workmanship and Defects.

### 5.6.6 Protective Coating.



## “Underground gas piping”

Black steel pipe is seldomly used underground due to problems with corrosion protection. Problems currently exist with pipe wrap materials **(not listed for application)** being installed. Additional problems also exist when piping is wrapped before the required testing.





## 2012 National Fuel Gas Code

- 5.6.7 Metallic Pipe Threads
- 5.6.7.4\* Thread Joint Compounds. Thread joint compounds shall be resistant to the action of LP-Gas or to any other chemical constituents of the gases to be conducted through the piping.



**NOTE: Pipe dope such as;**

**Hercules, PRO DOPE is NOT for use on LP-Gas systems.**

### **“Gas piping and equipment problems continued”**

- **The gas codes require pipe joint materials to be compatible with the type of gas being used. Many pipe dope materials are acceptable to be used on natural gas. Some of these products such as Pro-dope are not able to be used on propane piping. CHECK PIPE JOINT COMPOUND!**

## 2012 National Fuel Gas Code

- **5.6.8 Metallic Piping Joints and Fittings**
- **5.6.8.2 Tubing Joints.** Tubing joints shall be made with approved gas tubing fittings, be brazed with a material having a melting point in excess of 1000°F (538°C), or be made by press connect fittings complying with ANSI LC-4, *Press-Connect Copper and Copper Alloy Fittings for Use in Fuel Gas Distribution Systems*. Brazing alloys shall not contain more than 0.05 percent phosphorus
- NOTE: **EXAMPLE VIEGA**

## 2012 National Fuel Gas Code

### 5.6.9 Plastic Piping, Joints, and Fittings.

- **Plastic piping allowed outside underground ONLY!**

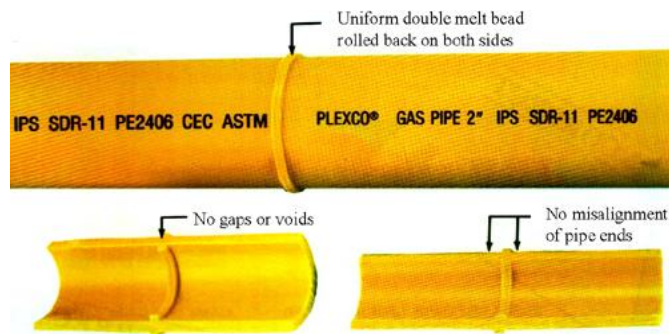

## “Gas piping and equipment problems continued”

- Poly plastic tubing can only be used outside underground only. The transition from plastic to steel is made underground with an anodeless riser.
- Tracer wire or approved metallic tape must be buried with the poly plastic to enable locating the piping at a later date.
- Poly plastic products are proprietary and cannot be mixed with other manufacturers. The manufacturer’s installation instructions are required in order to perform a proper inspection.

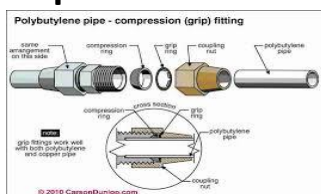

## 2012 National Fuel Gas Code

### 5.8 Gas Pressure Regulators. (Premises NOT Gas Co.)

#### 5.8.1 Where Required.

#### 5.8.2 Listing

#### 5.8.4 Location

#### 5.8.5 Regulator Protection

#### 5.8.6 Venting:

Line Gas Pressure Regulators & Second Stage LP-Gas Regulators.

Gas Appliance Pressure Regulators in accordance with Sections 5.8.6.1 and 5.8.6.2.

#### 5.8.7 Bypass Piping.

#### 5.8.8 Identification.



## “Gas regulator configuration”

Manufacturer’s installation instructions dictate the required regulator configuration.





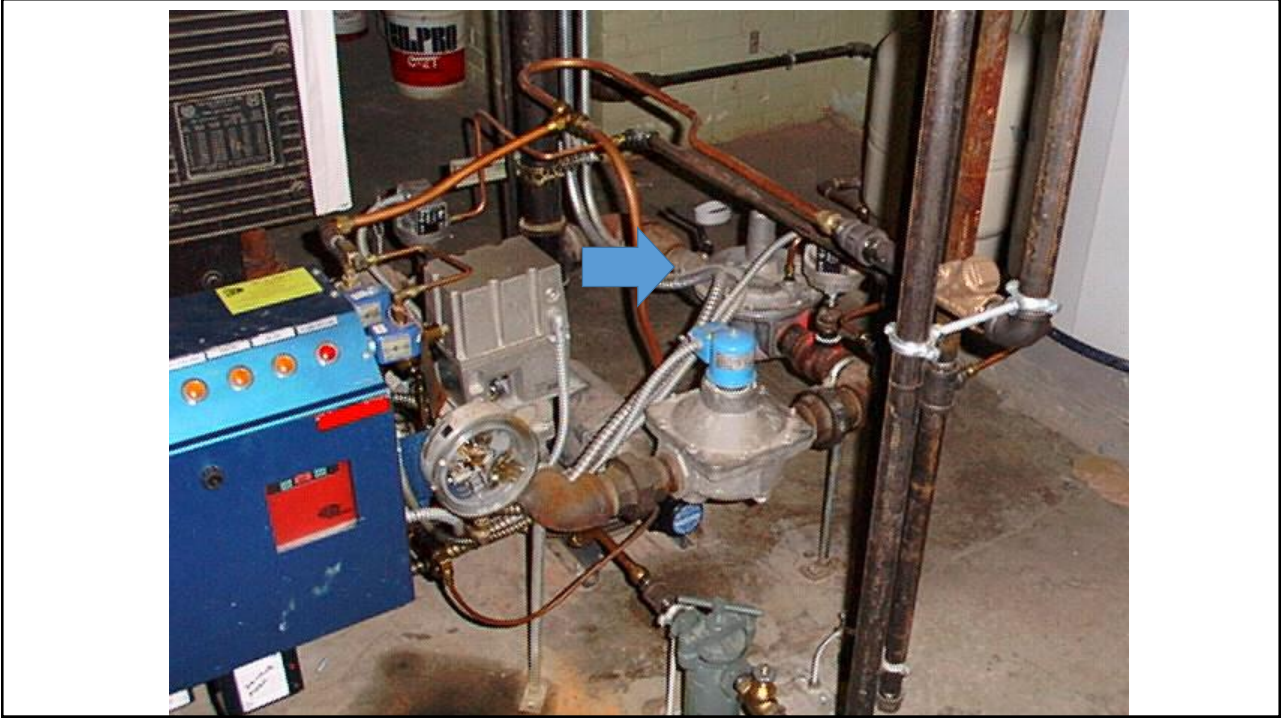

## Testing of gas regulator venting

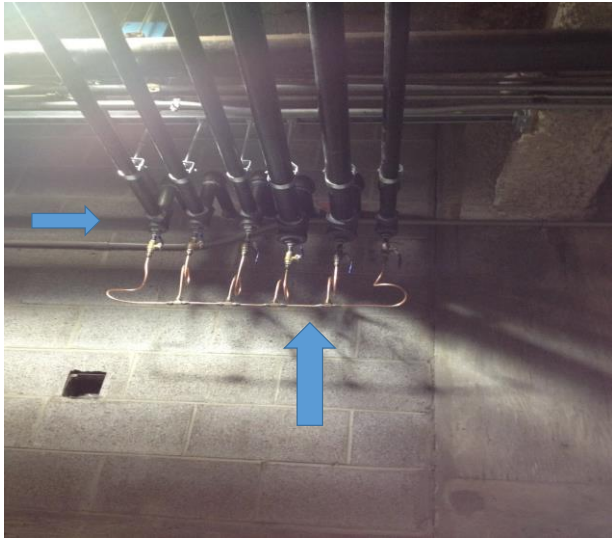



## Testing of gas regulator venting

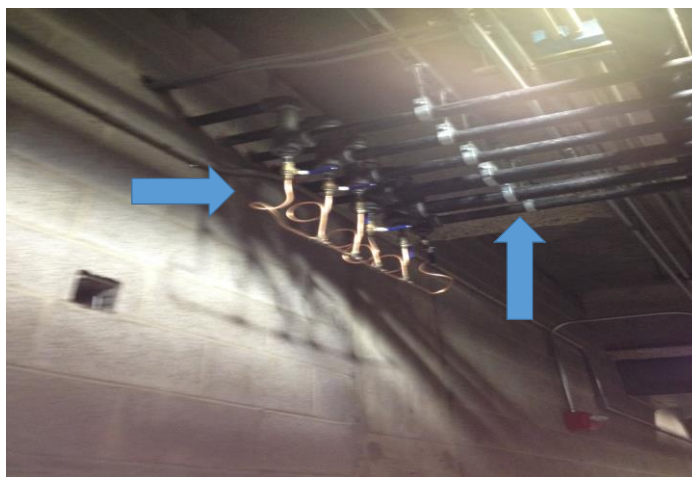

## 2012 National Fuel Gas Code

### Chapter 7 Gas Piping Installation

- 7.1 Piping Underground.
- 7.1.1 Clearances. Underground gas piping shall be installed with **sufficient clearance** from any other underground structure to avoid contact therewith, to allow maintenance, and to protect against damage from proximity to other structures. In addition, underground plastic piping shall be installed with sufficient clearance or shall be insulated from any source of heat so as to prevent the heat from impairing the serviceability of the pipe.

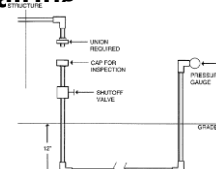

## Unprotected, unsupported, external gas piping



## Incorrectly installed gas piping.

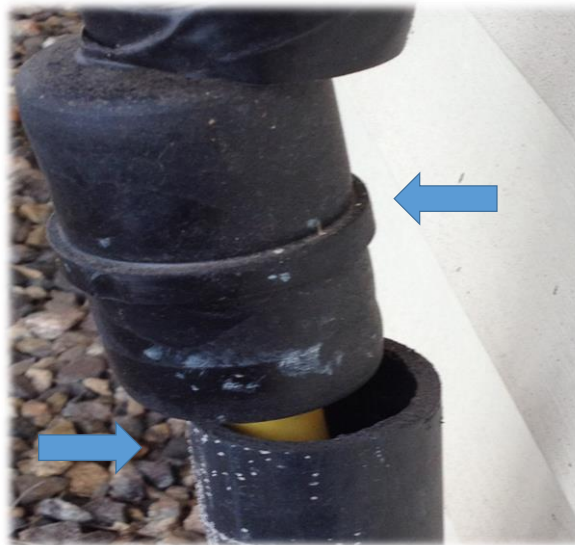

## **“Gas piping and equipment problems continued”**

- **The required testing of many of these pipe products is commonly performed utilizing a pressure test. Once the air pressure has been applied the joints are physically tested utilizing some type of detection liquid. The testing of CSST with leak tech solutions is limited. The solution to be used must be compatible with the corrugated stainless tubing. Solutions containing ammonia are detrimental to the tubing and if used will compromise the integrity of the tubing and over time will corrode causing the tubing to leak. SEE SLIDE #91.**
- **Exposed CSST subject to corrosion must be protected with appropriate tape.**
- **CSST products are proprietary and cannot be mixed with different manufacturers.**

## **“Gas piping and equipment problems continued”**

- **Many installers are using the CSST product as a replacement for code required unions and appliance connectors. These types of installations are not permitted**
- **CSST piping to be concealed must be properly protected at all penetrations. Special hardened steel nail plates must be used. These plates are more expensive than conventional nail plates and many installers are trying to substitute the less expensive plates.**

## Gas piping and equipment problems continued.

- CSST tubing
- **Yellow jacketed** (many companies manufacturing only the black jacketed product) Big box stores selling the yellow jacketed product. No test required to purchase and install these products! A brochure is handed to the purchaser and good to go.
- Black jacketed
- Installers in most cases are required by the manufacturers to attend a class related to their prospective product and take a test in order to purchase and install the product. A wallet registration card is issued to the installer upon successful completion of the test to identify the holder as certified to install the product. **We have found that although these installers hold the certification many still do not follow the instructions.**

## “Gas piping and equipment problems continued”

- The installation manual is extremely important when performing your inspection. **Without the instructions an inspection cannot be performed properly.**
- All piping system manufacturers have product installation manuals for proper installation!!!
- The CSST manufacturers have specific requirements for the installation of their products which must be followed. **The manual is required to enable a proper inspection!!**

## 2012 National Fuel Gas Code

- **7.2.2 Building Structure.**
- **7.2.3 Gas Piping to be Sloped.**
- **7.2.4 Prohibited Locations.**
  - **7.2.4\* Prohibited Locations.** Gas piping inside any building shall not be installed in or through a clothes chute, chimney or gas vent, dumbwaiter, elevator shaft, or air duct, other than combustion air ducts.

## 2012 National Fuel Gas Code

- **7.2.5 Hangers, Supports, and Anchors.**
- **7.2.5.1** Piping shall be supported with metal pipe hooks, metal pipe straps, metal bands, metal brackets, metal hangers, or building structural components, suitable for the size of piping, of adequate strength and quality, and located at intervals so as to prevent or damp out excessive vibration. Piping shall be anchored to prevent undue strains on connected appliances and equipment and shall not be supported by other piping. Pipe hangers and supports shall conform to the requirements of ANSI/MSS SP-58, *Pipe Hangers and Supports — Materials, Design and Manufacture*.
- **Plastic pipe clips, plastic j-hooks and nylon ty wraps are just a few of the products not permitted but used on many projects.**



## 2012 National Fuel Gas Code

### 7.6 Drip and Sediment Traps.

#### 7.6.1 Provide Drips Where Necessary.

#### 7.6.2 Location of Drips.

#### 7.6.3 Sediment Traps

The installation of sediment traps shall be in accordance with 9.6.7

**NOTE: STRESS THE DIFFERENCE**

**No drips for Connecticut!!!! According to Utilities!!!!**

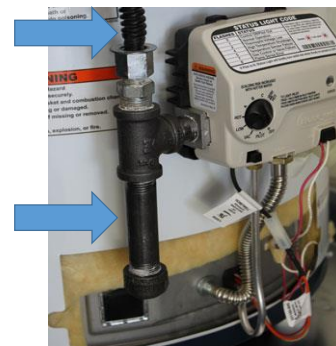

## Gas piping and equipment problems continued.

- Incorrect installations of code required sediment traps. When installed incorrectly dirt and debris are allowed to enter gas valves etc. would could create serious problems.
- Much confusion exists between drips and sediment traps. Drips were required to catch condensate within the piping. Gas suppliers (natural and propane) have confirmed that no moisture found in their products. Many installing contractors do not install the code required sediment traps on equipment such as roof top units thinking these traps would collect water and freeze. These sediment traps are in many cases not only code required but also required by the equipment manufacturer and must be installed for safe operation.

## “SEDIMENT TRAP”

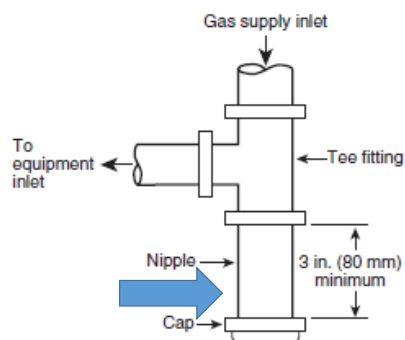

FIGURE 9.6.7 Method of Installing a Tee Fitting Sediment Trap.

## 2012 National Fuel Gas Code

Walk the line in it's **entirety !!!**  
**Know What Your Approving!!!**

### **7.7 Outlets.**

#### **7.7.1 Location and Installation.**

#### **7.7.2 Cap All Outlets.**

## 2012 National Fuel Gas Code

### 7.8 Branch Pipe Connections

### 7.9 Manual Gas Shutoff Valves.

#### 7.9.1 Valves at Regulators.

#### 7.9.2 Valves Controlling Multiple Systems.

Accessibility of Gas Valves.

Shutoff Valves for Multiple House Lines.

Emergency Shutoff Valves. **COMMENT**

Shutoff valve for Laboratories:



**NOTE: All valves are NOT GOOD for gas !!!**

## 2012 National Fuel Gas Code

### 7.13 Electrical Bonding and Grounding.

- **7.13.1 Pipe and Tubing Other than CSST.** Each aboveground portion of a gas piping system, other than CSST, that is likely to become energized shall be electrically continuous and bonded to an effective ground-fault current path. Gas piping, other than CSST, shall be considered to be bonded when it is connected to appliances that are connected to the appliance grounding conductor of the circuit supplying that appliance.



## 2012 National Fuel Gas Code

- **7.13.2\* CSST. CSST gas piping systems shall be bonded to the electrical service grounding electrode system. The bonding jumper shall connect to a metallic pipe or fitting between the point of delivery and the first downstream CSST fitting. The bonding jumper shall not be smaller than 6 AWG copper wire or equivalent. Gas piping systems that contain one or more segments of CSST shall be bonded in accordance with this section.**

## 2012 National Fuel Gas Code

- **8.1.5 Detection of Leaks or Defects.**
- **8.1.1.5 A piping system shall be tested as a complete unit or in sections. Under no circumstances shall a valve in a line be used as a bulkhead between gas in one section of the piping system and test medium in an adjacent section, unless two valves are installed in series with a valved "telltale" located between these valves. A valve shall not be subjected to the test pressure unless it can be determined that the valve, including the valve closing mechanism, is designed to safely withstand the pressure.**

## 2012 National Fuel Gas Code

- **8.1.5.2** The leakage shall be located by means of an approved gas detector, a **noncorrosive** leak detection fluid, or other approved leak detection methods. **Matches, candles, open flames, or other methods that provide a source of ignition shall not be used.**

**NOTE: CORROSIVE PRODUCTS SUCH AS 409 CANNOT BE USED TO DETECT LEAKS!!!!!!!**

## 2012 National Fuel Gas Code

### 8.3 Purging.

#### 8.3.1 Piping Systems Required to be Purged Outdoors

##### 8.3.1.1 Removal from Service.

See Table 8.3.1

##### 8.3.1.2 Placing in Operation. (Piping)

See Table 8.3.1

##### 8.3.1.3 Outdoor Discharge of Purged Gases.



## 2012 National Fuel Gas Code

### **Chapter 9 Appliance, Equipment and Accessory Installation (cont)**

**9.1.17 Avoid Strain on Gas Piping**

**9.1.18 Gas Appliance Pressure Regulators**

**9.1.19 Venting of Gas Appliance Pressure Regulators (in  
part.....)**

- **(2) Vent limiting means shall be employed on listed  
appliance pressure regulators only.**

## 2012 National Fuel Gas Code

**9.1.20 Bleed Line for Diaphragm-Type Valves**

**9.1.21 Combination of Appliances and  
Equipment**

**9.1.22 Installation Instructions! THIS IS MOST  
IMPORTANT!!!!!! You can't do the inspection  
without the installation instructions!**

**9.1.23 Protection of Outdoor Appliance**

## Gas piping issues.



## 2012 National Fuel Gas Code

### 9.2 Accessibility and Clearance.

#### 9.2.1 Accessibility for Service.

- **9.2.1 Accessibility for Service.** All appliances shall be located with respect to building construction and other equipment so as to permit access to the appliance. Sufficient clearance shall be maintained to permit cleaning of heating surfaces; the replacement of filters, blowers, motors, burners, controls, and vent connections; the lubrication of moving parts where necessary; the adjustment and cleaning of burners and pilots; and the proper functioning of explosion vents, if provided. For attic installation, the passageway and servicing area adjacent to the appliance shall be floored.

• **NOTE: FOLLOW INSTALLATION INSTRUCTIONS!!!!**

## 2012 National Fuel Gas Code

### 9.4 Appliances on Roofs

#### 9.4.1 General

#### 9.4.2 Installation of Appliances on Roofs

9.4.2.2 Appliances shall be installed on a well-drained surface of the roof. **At least 6 ft** (1.8 m) of clearance shall be available between any part of the appliance and the edge of a roof or similar hazard, or rigidly fixed rails, guards, parapets, or other building structures at least 42 in. (1.1 m) in height shall be provided on the exposed side.

**NOTE: DIFFERS FROM THE INTERNATIONAL MECHANICAL CODE (IMC) !  
10 foot requirement in the IMC.**

## 2012 National Fuel Gas Code

### 9.4.3 Access to Appliances on Roofs

- **9.4.3.2 Buildings of more than 15 ft (4.6 m) in height shall have an inside means of access to the roof, unless other means acceptable to the authority having jurisdiction are used.**
- **This referenced height of 15 feet also differs from the IMC which requires 16 feet and the IMC does not specifically require the access to be from inside.**



## Equipment On Roofs Or Elevated Structures



## “Continuation of outside regulator gas vent piping”



## 2012 National Fuel Gas Code

- **10.23 Room Heaters.**
- **10.23.1\* Prohibited Installations.** Unvented room heaters shall not be installed in bathrooms or bedrooms. **“With 2 exceptions”**
- **The building and fire code, along with the NFPA 54 document are silent when it comes to utilizing unvented room heaters as a sole source of heat. These units were never intended to be the only source of heat. The International Residential Code (IRC) prohibits their use as a sole source of heat. Many landlords have attempted to change their current systems hoping that the tenant would then be able to pay for their own heat. The building code has certain comfort heating requirements that should assist the inspector in requiring a system other than unvented.**



## 2012 National Fuel Gas Code

### Chapter 11 Procedures to be Followed to Place Equipment in Operation.

This part deals with the placing of a gas utilization equipment into operation.

**11.7 “Operating Instructions.” Operating instructions shall be furnished and shall be left in a prominent position near the equipment for the use of the consumer.**

## 2012 National Fuel Gas Code

- **Chapter 12 : Venting of Appliances**
- **12.5.2 Plastic Piping.** Plastic piping used for venting appliances listed for use with such venting materials shall be approved. **EXPLAIN!**
- **12.5.3 Plastic Vent Joints.** Plastic pipe and fittings used to vent appliances shall be installed in accordance with the appliance manufacturer’s installation instructions.
- **Where primer is required, it shall be of a contrasting color!**

## 2012 National Fuel Gas Code

- **12.6.4 Inspection of Chimneys.**
- **12.6.4.1** Before replacing an existing appliance or connecting a vent connector to a chimney, the chimney passageway shall be examined to ascertain that it is clear and free of obstructions and shall be cleaned if previously used for venting solid or liquid fuel-burning appliances or fireplaces.
- **12.6.4.2 Chimneys shall be lined in accordance with NFPA211, *Standard for Chimneys, Fireplaces, Vents, and Solid Fuel-Burning Appliances.***

## 2012 National Fuel Gas Code

- **12.7.3.1\* Category I Appliances.** The sizing of natural draft venting systems serving one or more listed appliances equipped with a draft hood or appliances listed for use with a Type B gas vent, installed in a single story of a building, shall be in accordance with one of the following: TABLE 12.7.2
- **12.7.3.3 Category II, Category III, and Category IV Appliances.** The sizing of gas vents for Category II, Category III, and Category IV appliances shall be in accordance with the appliance manufacturer's instructions.

## Problems with gas furnace direct venting



## Gas venting problems, direct vent



## Direct vent water heater termination “problem”



## Gas Venting Terminations Direct Vent Equipment, examples.



**QUESTIONS?**