

SOUTH STAMFORD ACCESSIBILITY & MNRR BRIDGE REPLACEMENT FEASIBILITY STUDY

State Project No. 135-301
Stamford, Connecticut

PRELIMINARY ENGINEERING REPORT

Volume 4 of 7

CANAL STREET

January 4, 2012



State of Connecticut
Department of Transportation

URS

500 Enterprise Drive, Suite 3B
Rocky Hill, CT 06067
Tel.: (860) 529-8882
Fax: (860) 529-3991
www.urscorp.com

TABLE OF CONTENTS – CANAL STREET

1. INTRODUCTION	1
1.1 Site Location and Description	1
1.2 Site Features	1
1.3 Proposed Improvements	2
2. HIGHWAY DESIGN	2
2.1 Horizontal Alignments and Lane Arrangements	2
2.2 Vertical Profiles	3
2.3 Rights-of-Way	3
2.4 Exceptions to Geometric Design Criteria	3
3. RAIL OPERATIONS	4
3.1 Rail Staging and Sequencing Requirements	4
3.2 Impact and Operational Issues of Proposed Construction	5
3.3 Summary and Conclusions	7
4. BRIDGE 03678R – MNR OVER CANAL STREET	7
4.1 Existing Bridge	7
4.2 Proposed Improvements	8
4.2.1 Critical Controls	8
4.2.2 Superstructure Types	9
4.2.3 Abutments	11
4.2.4 Pier	11
4.2.5 Retaining Walls	12
4.2.5.1 Roadway Retaining Walls	12
4.2.5.2 Railroad Retaining Walls	12
4.3 Phased Construction Requirements	12
4.3.1 Suggested Superstructure Erection Method	13
4.4 Aesthetic Treatments	13
4.5 Summary and Conclusion	13
4.5.1 Structure Summary	13
4.5.2 Construction Duration	14
4.5.3 Estimated Construction Cost	14
5. OTHER STRUCTURES	15
6. TRAFFIC	15
6.1 Traffic Operational Requirements	15
6.2 M&PT Requirements	16
7. DRAINAGE	17
7.1 Existing System Conditions	17
7.2 System Constraints	18

TABLE OF CONTENTS (continued)

7.3	Concepts Considered.....	19
7.4	Design Criteria.....	19
7.4.1	Gutter Flow.....	19
7.4.2	Pipe Flow.....	20
7.4.3	Hydraulic Grade Line.....	20
7.5	Summary of Impacts and Proposed Improvements.....	20
8.	UTILITIES.....	20
9.	GEOTECHNICAL.....	21
9.1	Summary of Subsurface Data.....	21
9.1.1	Regional Geology.....	21
9.1.2	Pilot Borings.....	21
9.1.3	Subsurface Conditions.....	21
9.1.4	Soil.....	22
9.1.5	Groundwater.....	22
9.2	Geotechnical Construction Issues.....	22
9.3	Foundation Recommendations.....	23
10.	ENVIRONMENTAL.....	23
10.1	Required Environmental Permits.....	23
11.	SUMMARY AND CONCLUSIONS.....	24

APPENDIX

Appendix A	– Highway Design Criteria.....	25
Appendix B	– Bridge Design Criteria.....	26
Appendix C	– Construction Schedule.....	28
Appendix D	– Construction Cost Estimates.....	30
Appendix E	– Drainage Calculations.....	33
Appendix F	– Boring Logs.....	38
Appendix G	– Figures.....	45

LIST OF FIGURES

Highway

- Figure 2.1 – Project Area
- Figure 2.2 – Roadway Plan
- Figure 2.3 – Roadway Profile
- Figure 2.4 – Roadway Cross Section

LIST OF FIGURES *(continued)*

Rail Operations

Figure 3.1a-g – Rail Staging and Sequencing Plans for Bridge 03678R

Bridge 03678R

Figure 4.1 – General Plan & Elevation

Figure 4.2 – Typical Sections

Figure 4.3a-d – Construction Staging Sections

Figure 4.4 – Abutments

Figure 4.5 – Pier

Traffic

Figure 6.1a-b – Maintenance and Protection of Traffic

Drainage

Figure 7.1 – Drainage Plan

Utilities

Figure 8.1 – Utility Plan

Geotechnical

Figure 9.1 – Boring Plan

Environmental

Figure 10.1 – 100 Year FEMA Floodplain

1. INTRODUCTION

1.1. Site Location and Description

This Metro-North Railroad (MNR) undergrade¹ bridge is located at mile post 33.41 on the New Haven Line. The bridge carries seven MNR tracks over Canal Street. Immediately to the north, Canal Street intersects with South State Street and the U.S. Interstate 95 (I-95) northbound entrance ramp 8 at a five-legged intersection. The Canal Street/South State Street intersection is state assigned intersection number 135-268. I-95 is approximately 210 feet north of the underpass. Approximately 250 feet to the south of the underpass, Canal Street intersects with the proposed Stamford Urban Transit Way (SUT), currently under construction. Please refer to Figure 2.1 for the project area, located in Appendix G.

1.2. Site Features

Currently at the underpass, Canal Street is an undivided four-lane roadway with two lanes traveling in both directions and no shoulders. The lane widths are approximately 10 feet each which when combined, provide a curb-to-curb width of 40 feet. There are sidewalks on both sides of Canal Street that vary from six feet to eight feet in width.

North of the underpass, Canal Street intersects with South State Street and the I-95 northbound entrance ramp. This is a five-leg, signalized intersection. South State Street is a one-way street carrying traffic in the eastbound direction. Approaching Canal Street from the west, South State Street carries four, 12-foot lanes of traffic, with no shoulders, at an approximate downgrade of 1.0 percent. South State Street continues east of Canal Street carrying three lanes of traffic, with no shoulders, at a relatively flat grade. The I-95 northbound entrance ramp has a steep grade of 5.0 percent. South State Street and the I-95 entrance ramp are separated by a retaining wall due to the difference in grade. Just beyond the five-legged intersection, Canal Street widens at the I-95 underpass to include an additional through-lane in the northbound direction.

South of the undergrade bridge, Canal Street widens to include an additional lane in the southbound direction as it approaches the proposed SUT. The intersection with the SUT is a signalized intersection.

The alignment of Canal Street follows an angle point of approximately 23 degrees. The angle point is located at the intersection with South State Street and the I-95 northbound entrance ramp. The vertical geometry is a tangent with a relatively flat grade. The existing intersection sight distance (ISD) for the Canal Street approach to South State Street is approximately 260 feet, which corresponds to a design speed of approximately 23 miles per hour (mph) for a passenger car design vehicle.

¹ An “Undergrade Bridge,” in rail terms, refers to a road going under the grade of the railroad or under the track. In this case, the bridge acts to carry the tracks over East Main Street resulting in an undergrade bridge.

Catenary towers are located approximately 60 feet west and 90 feet east from the west and the east abutments, respectively. On the southwestern corner of the bridge is an MNR lot that has an abandoned brick building located immediately behind the bridge abutment wall. This building appears to be integral with the wingwall. The southeastern corner of the bridge is an MNR rail yard bound by a retaining wall along Canal Street that abuts the corner of the east abutment.

1.3. Proposed Improvements

Proposed improvements to Canal Street include widening the travel lanes from 10 feet to 11 feet, adding two-foot shoulders, and providing a median to divide opposing traffic. A right-turn only lane will be added in the northbound direction and will reduce queuing, freeing movements for through traffic. This project will match the alignment of Canal Street under I-95 on its north side and the proposed SUT alignment on its south side. These lanes will provide additional capacity needed for passage of cars north and south of the bridge. Improvements made to this underpass will reduce congestion along North State Street, Atlantic Street and Washington Boulevard in the surrounding area of the Stamford Intermodal Transportation Center (SITC).

Proposed work includes the total reconstruction of the superstructure and substructure of the undergrade bridge. The deck type proposed for the bridge is the MNR preferred ballasted deck rather than the open deck currently in place. The reconstruction of the bridge will support the roadway improvements, eliminate a structurally deficient bridge, and will provide a vertical clearance that will permit the passing of all legal height vehicles. The largest vehicles owned and operated by the City of Stamford include a HazMat truck and the Police Department's command vehicle. Both of these vehicles have a height of 12'-6". The posted vertical clearance is currently 13'-11". A Bridge Inspection Report dated October of 2008, cited the measured minimum vertical clearance to be 14'-2". Surveyed vertical clearance was determined to be 14'-0".

2. HIGHWAY DESIGN

2.1. Horizontal Alignments and Lane Arrangements

The proposed lane arrangements for Canal Street are based on discussions with the Connecticut Department of Transportation (CTDOT) and City of Stamford. Please refer to Figure 2.4 for the proposed Canal Street cross section. The proposed lane arrangements include:

- two 11-foot lanes in the southbound direction
- three 11-foot lanes in the northbound direction
- 2-foot shoulders; inside and outside
- an 8-foot median which will also accommodate a bridge pier
- 8-foot wide sidewalks

The Canal Street curb-to-curb width will total 71 feet.

The proposed horizontal alignment for the Canal Street underpass is similar to the existing layout with a 220 foot radius at the inside edge of the traveled way on the south side of the bridge, and a radius of 232 feet on the north side of the bridge. This will match Canal Street with its alignment under I-95 to the north and the SUT alignment to the south. Please refer to Figure 2.2 for the roadway plan, located in Appendix G. A simple curve was considered but deemed not viable due to its impact on the existing rail yard located on the southeast corner of the underpass.

The South State Street intersection with Canal Street provides an intersection sight distance (ISD) of 260 feet, which does not meet the required ISD for a posted speed of 30 mph. Designing the intersection to provide for the required ISD will significantly impact the urban roadway and will consequently require a design exception. A clear zone distance of 14 feet is required for design speeds of 40 mph or less. The available clear zone at Canal Street is approximately 10 feet. As a result, a design exception will be required for this as well. Please refer to Appendix A for all highway design criteria.

2.2. Vertical Profiles

Since the MNR profile cannot be altered, the vertical profile of Canal Street at the underpass will be determined by the depth of the proposed Metro-North bridge. The desired minimum vertical clearance is 14'-6". The proposed Canal Street bridge will meet the vertical clearance requirement without adjusting the profile of the roadway. Please refer to Figure 2.3 for the Canal Street roadway profile.

2.3. Rights-of-Way

The parking lot to the south of the Canal Street bridge and a MNR facility building will be impacted.

There is a catenary tower located to the east side of Canal Street. The foundation of the tower will be in conflict with the new abutment footing. It is proposed that the tower be moved further east to ensure the foundations will not be in conflict.

2.4. Exceptions to Geometric Design Criteria

Since the intersection sight distance does not meet the criteria for a design speed of 30 mph, a design exception will be required. The available clearzones also do not meet the criteria and will also require a design exception.

3. RAIL OPERATIONS

3.1. Rail Staging and Sequence Requirements

The Canal Street Bridge is an undergrade structure on the New Haven Line at mile post (MP) 33.41 in Stamford. The bridge is situated in CP234. The bridge is situated between CP234 and CP235. CP234 and CP235 are interlockings². The “CP” signifies Control Point, the “2” indicates that the interlockings are located on the New Haven Line, and the last two digits indicate approximate mile posts.

The Canal Street bridge is located approximately 1,100 feet east of the Stamford Intermodal Transportation Center (SITC). The bridge carries seven tracks: North Yard Track 7, the New Canaan Branch (Track 5), the four New Haven Line tracks, numbered 3, 1, 2, and 4, and Yard Track 6. Replacement of the bridge will be done one track at a time. The replacement work will require that each track be taken out of service while the reconstruction work on the portion of the bridge under that track is performed. The bridge replacement work can be done either working in the north to south, or the south to north direction.

The construction staging plans for Canal Street bridge (refer to appendix C, Construction Schedule) show the reconstruction of the bridge being progressed in a north to south direction (Track 7 to Track 6). The bridge reconstruction work is done in seven main stages. Each of these stages will require a continuous track outage for the track being replaced on the portion of the bridge being reconstructed. It is estimated that the duration of the continuous track outages required for each track reconstruction will be 150 calendar days.

The continuous track outages will not impact the use of the passenger platforms at the SITC. During these outages however, the normal routing of westbound trains into the station area will have to be adjusted to accommodate the out-of-service tracks on the Canal Street bridge.

The continuous track outage during Stage 1 will take North Yard Tracks 7 and 9 out of service. These tracks will remain out of service until the Track 7 work on the bridge is completed. Train operations that normally use these tracks will need to be adjusted for this track outage.

During the Stage 7 work, Track 6 on the Canal Street Bridge will be out of service. This track outage will impact train operations and access into Yard Tracks 6, 8, 10, 12, the Lower Stamford Yard and MNR’s Maintenance of Equipment facility.

² Interlockings are switches and/or crossovers that allow trains to travel from one track to another governed by signal indications. On the New Haven line, these points are remotely controlled by the MNR Operations Control Center.

With the mobilization period, the 150 calendar days required for each continuous track outage, and the approximate 5 month period to complete the roadway work under the bridge, the total project duration time for the replacement of the Canal Street bridge is estimated to be 3 years, 10 months.

3.2. Impact and Operational Issues of Proposed Construction

At the Canal Street bridge, there will be critical impacts to Metro-North train operations when Track 6 is removed during the replacement of that portion of the bridge. Track 6 over the Canal Street bridge is the primary route for all revenue service trains originating and terminating in Stamford. It is also used for trains being routed into and out of the Maintenance of Equipment facility. This track and the adjacent crossovers are extremely important to train operations in this area. The use of the available alternate routing (back door crossover) at the east end of the yard is highly undesirable.

Replacement of Track 7 (North Yard Track) - Please refer to Figure 3.1a for rail staging and sequencing plans pertaining to the replacement of Track 7. When Track 7 at the Canal Street bridge is under construction, the west entrance to this yard track will be out of service. Track 7 and Track 9, are primarily used for train storage. During the reconstruction of Track 7 on the bridge, access to Track 7 and Track 9 from the west end will not be possible.

The Track 7 outage on the bridge will not impact the four passenger platform tracks or Track 1 at the SITC.

Westbound trains on Track 5 will use the east end switch (entrance) to Track 7.

Replacement of Track 5 (New Canaan Branch) - Please refer to Figure 3.1b for rail staging and sequencing plans pertaining to the replacement of Track 5. The Track 5 outage at the Canal Street bridge will not require any of the four passenger platform tracks or Track 1 in the SITC to be taken out of service.

Eastbound trains on Track 5 will use the 5-3 and the 3-5 crossovers in CP234 to run around the bridge work on Track 5.

Westbound trains on Track 5 will be able to use the 3-5 and 5-3 crossovers in CP234 to run around the Track 5 outage at the Canal Street bridge.

Replacement of Track 3 - Please refer to Figure 3.1c for rail staging and sequencing plans pertaining to the replacement of Track 3. The Track 3 outage at the Canal Street bridge will impact the four passenger platform tracks or Track 1 at the SITC.

Eastbound trains on Track 3 will use the 3-1 and the 1-3 crossovers in CP234 to run around the bridge work on Track 3.

Westbound trains on Track 3 will be able to use the 1-3 and 3-1 crossovers in CP234, or the 5-3 crossover in CP235 to run around the Track 3 outage at the Canal Street bridge.

Replacement of Track 1 - Please refer to Figure 3.1d for rail staging and sequencing plans pertaining to the replacement of Track 1. The Track 1 outage at the Canal Street bridge will not impact the four passenger platform tracks or Track 1 at the SITC.

Eastbound trains on Track 1 will be diverted from Track 1 in SELLECK, CP233, or CP234 to run around the bridge work on Track 1.

Westbound trains on Track 1 will be able to use the 3-1 crossover in CP235 to run around the Track 1 outage at the Canal Street bridge.

Replacement of Track 2 - Please refer to Figure 3.1e for rail staging and sequencing plans pertaining to the replacement of Track 2. The Track 2 outage at the Canal Street bridge will not impact the four passenger platform tracks or Track 1 at the SITC.

Eastbound trains on Track 2 will be diverted from Track 2 in SELLECK, CP233, or CP234 to run around the bridge work on Track 2.

Westbound trains on Track 2 will have to use the crossovers in CP240 and/or CP241 to divert from Track 2 to an adjacent in-service track to run around the Track 2 outage at the Canal Street bridge.

Replacement of Track 4 - Please refer to Figure 3.1f for rail staging and sequencing plans pertaining to the replacement of Track 4. The Track 4 outage at the Canal Street bridge will not impact the four passenger platform tracks or Track 1 at the SITC.

Eastbound trains on Track 4 will use the 4-2 and E2-4 crossovers in CP234 to run around the bridge work on Track 4.

Eastbound yard (terminating) and westbound yard (originating) trains can use the 2-4 and 4-6 crossovers in CP234 for entering/exiting Lower Stamford Yard.

Westbound trains on Track 4 will be able to use the E2-4 and 4-2 crossovers in CP234 to run around the Track 4 outage at the Canal Street bridge.

Replacement of Track 6 (Yard Entrance Track and 4-6 Crossover) - Please refer to Figure 3.1g for rail staging and sequencing plans pertaining to the replacement of Track 6. When Track 6 is taken out of service at the Canal Street bridge, the normal route for all trains into and out of Lower Stamford Yard will be taken out of service.

This will have a critical impact to railroad operations since this track and the adjacent 4-6 crossover are the primary tracks used by all trains originating and terminating in Stamford. This track and crossover are also used for all trains being routed to the MNR Maintenance of Equipment facility.

This may be an area where a temporary crossover or track throw can be used to allow access and train movements into Lower Stamford Yard. Either of these options, or other possible options, will have to be further considered by CTDOT and Metro-North.

A secondary access to the Lower Stamford Yard is located at the east end of the yard (back door crossover). This crossover is operated manually and is currently used only in emergencies.

3.3. Summary and Conclusions

Construction of the Canal Street bridge will impact train operations east of the SITC in CP234. Track 7 reconstruction will impact use of North Yard Tracks 7 and 9. Canal Street bridge Track 6 reconstruction will impact train operations and access into Yard Tracks 6, 8, 10, 12, the Lower Stamford Yard, and the Maintenance of Equipment facility.

Additional discussions will be required with CTDOT and Metro-North to consider solutions for maintaining train operations into the yard areas and the Maintenance of Equipment facility when Track 6 is reconstructed.

Bridge construction will not substantially impact train operations through the SITC area. The Canal Street bridge work will require adjustments to normal train routing during reconstruction of each of the tracks over the bridge.

It is not recommended to have this bridge be reconstructed in the same time frame as the Atlantic Street or Greenwich Avenue bridges because all of these bridges are within CP233 and/or CP234. The concurrent construction with either of them could cause substantial and severe train operation restrictions in the CP234 interlocking, and to the passenger platform tracks at the SITC.

Canal Street can be considered for concurrent reconstruction with the Elm Street and East Main Street bridges. Metro-North should be consulted for its concurrence regarding these recommendations, and to determine any other train operation impacts.

4. BRIDGE 03678R – MNR OVER CANAL STREET

4.1. Existing Bridge

The existing Metro-North bridge is identified as Bridge No. 03678R located at MP 33.14. Constructed in 1896, the bridge carries seven tracks over Canal Street. The

bridge has been rated for a Cooper E65.4 loading as its Normal Load Rating. The out-to-out deck width is approximately 90 feet. The bridge is posted with a minimum vertical clearance of 13'-11" and a surveyed vertical clearance of 14'-0".

The bridge is an open deck with a single, simple span. The steel-framed superstructure consists of seven pairs of built-up, riveted plate girder stringers, spanning approximately 65 feet. The out-to-out width of the bridge is 84'-6". Please refer to Figure 4.2 for a typical section of the existing structure, located in Appendix G.

The superstructure is supported by gravity-type brownstone masonry abutments. The wingwalls are also gravity-type walls constructed of brownstone masonry. The wingwalls run approximately parallel to the tracks and butt into the stone masonry retaining walls that support the railroad embankment. The substructure, including abutments and wingwalls, are founded on timber piles and timber grillage.

In a bridge inspection report dated October of 2008, the superstructure and the substructure are reported to be in fair condition with an overall rating of "5" out of "10". The superstructure has some cracking and severe section loss on the bottom flanges. The substructure is in fair condition. The abutments have experienced the movement of stones in the backwall, resulting in the stones coming into contact with the superstructure girders and also settlement under the bearings.

4.2. Proposed Improvements

Proposed improvements include:

1. Increase the bridge span length to accommodate the wider curb-to-curb width of Canal Street
2. Increase the vertical clearance to accommodate all legal height vehicles.

Please refer to Appendix B for all bridge design criteria.

4.2.1. Critical Controls

In order to accommodate the roadway widening, it is necessary to increase the bridge span length by setting the west and east bridge abutments back behind the existing abutments by 19'-4" and 38'-9", respectively. This distance is measured along the centerline of MNR Track 1 from the existing abutment face. The proposed road is skewed approximately 5.5 degrees counterclockwise from the existing centerline of roadway in order to match the alignment of Canal Street with I-95 to the north and the SUT to the south. Setting the abutments back increases the span length from approximately 64'-9" to 102'-11". Please refer to Figure 4.1 for the general plan and elevation of the proposed Canal Street undergrade bridge, located in Appendix G.

To provide a shallower superstructure, the proposed bridge will consist of two simple spans, 44.8 feet and 55.8 feet, supported by two full height abutments and a pier located between the northbound and southbound lanes. The location of the pier also serves to divide opposing traffic. The proposed pier layout conforms to the proposed horizontal roadway alignment. Lane delineations, curb locations, and abutments are offset from the centerline of the pier. The centerline of bearing locations are also offset from the centerline of the pier.

A requirement of Metro-North is that the elevation and horizontal alignment of the MNR tracks remain unchanged. Since the tracks cannot be raised, the required minimum vertical clearance of 14'-6" in conjunction with the depth of proposed structure will control the vertical geometry of Canal Street. The final vertical profile of Canal Street will dictate the extent that Canal Street will need to be lowered and the degree this will impact adjacent intersections and roadways as well as adjacent properties.

In addition, overhead catenary wires will be de-energized but will be maintained during construction activities, thereby restricting headroom. This constraint will limit the use of overhead equipment, e.g. cranes. This is especially important during construction of the foundations and erection of the superstructure.

The existing foundations are constructed of timber piles and timber grillage. The proposed abutments were purposefully located behind the existing foundations so that the existing piles and grillage could be left in place and would not conflict with the proposed foundations.

4.2.2. Superstructure Types

Several bridge types were considered for the preliminary engineering study including:

- ballasted deck half-through girders
- 2-girder ballasted concrete deck
- multi-steel girder ballasted steel plate deck
- precast multi concrete-encased beams
- prestressed butted box beams

The controlling design span length is approximately 56 feet, controlled by Span 2 over the northbound travel lanes of Canal Street. The superstructure depth is measured from the top of track to the bottom of the girder. This includes common dimensions like $7\frac{5}{16}$ -inch rail height, 8½-inch concrete ties, 8½-inch minimum ballast thickness, and 1-inch ballast mat. Dimensions for a specific structure types include a 13-inch concrete deck with haunch for the two-girder option, 1½-inch

steel deck plate for through-girder option, and 2-inch thick steel deck plate for the multi-steel girder option.

Half-Through Girders: This structure type allows the top of the girder to be above the deck but limited by the railroad clearance envelope. This permits a reduction in the superstructure depth, which is measured from the top of track to the bottom of the bottom flange. However, this may not be the case for short spans where the geometric configuration of the deck framing system would require larger superstructure depths than structurally required. Such is the case for the proposed Canal Street bridge, where a deeper through-girder superstructure depth is required in comparison to the existing superstructure and the precast concrete-encased beam option.

Two-Girder Ballasted Concrete Deck: This superstructure type consists of two girders below a ballasted concrete deck. This is generally more economical compared to other superstructure types because it is the simplest to fabricate and to erect. One weakness of this structure type is that all girders are fracture critical. Additionally, it usually requires the greatest superstructure depth, adding to the amount Canal Street would have to be lowered in order to attain the required minimum vertical clearance.

Multi-Steel Girder Ballasted Steel Plate Deck: This framing system requires a shallower superstructure than a two-girder framing system. However, unlike the two-girder system, the multiple steel girders offer structural redundancy and are therefore not considered to be fracture critical. It is more economical to fabricate and to erect compared to a through girder system, but requires more maintenance throughout its design life. This steel superstructure requires a higher life-cycle cost than the precast multi concrete-encased beam alternative. This option requires a 5'-6" superstructure depth at Canal Street.

Precast Multi Concrete-Encased Beams: This superstructure type is economical and requires low maintenance. The butted beam construction allows for a ballasted track without the need to provide for an additional deck system. This structure type offers the shallowest superstructure depth among the alternatives considered, but usually requires the use of significantly more steel than the other alternatives. This system is appropriate for short to moderate span lengths. This alternative would require a 5'-6" superstructure depth at Canal Street.

Prestressed Butted Box Beams: Butted box beams are generally economical, easy to erect, and require low maintenance. Similar to the precast multi concrete-encased beams, they allow for a ballasted deck without the need to provide for an additional deck system. However, precast butted box beams offer limited superstructure depth options, generally requiring larger superstructure depths than

the precast multi concrete-encased beams. For this reason, this alternative will not be considered in this study.

After consideration of the advantages and disadvantages of each superstructure type, the multi-steel girder and the precast multi concrete-encased beam structure types are the most viable alternatives for this application and therefore will be presented in this report. Please refer to Figure 4.2 for typical sections of proposed structure types, located in Appendix G.

4.2.3. Abutments

Because this bridge is being built in stages, it is proposed that the new abutments be constructed using a top-down construction technique. This construction technique allows for short stub abutments supported on mini-piles. Because this type of abutment and methodology requires less excavation and materials, controlled excavation can occur within close proximity to the adjacent, operating tracks. Drilled mini-piles are the recommended deep foundation for the abutments since they will allow ease of installation under low overhead conditions. The abutment seat will be constructed of cast-in-place concrete and the abutment wall will be built using a tie-back wall with steel walers, concrete lagging, and a concrete fascia aesthetically treated with concrete formliner. Please refer to Figure 4.4 for a plan and elevation view of Abutment 2, located in Appendix G.

4.2.4. Pier

Due to the increased length from centerline of the bridge and the need to provide a shallow superstructure, a two-span bridge is proposed. The two spans will be supported by new abutments and a new proposed pier.

The proposed pier will be comprised of a footing, pier cap and circular columns. The pier cap width is estimated to be 5'-6" in order to accommodate two rows of bearings. The circular columns are estimated to be 4-foot in diameter and will be supported on an 8-foot wide pile cap founded on mini-piles. Two-foot vertical traffic barriers will be placed on either side of the pier columns to protect the columns from vehicular collisions.

The narrow footing will be founded on mini piles which are ideal for low overhead clearance and where a spread footing is not a viable option. A spread footing is not a viable option at this location due to maintenance of traffic.

Please refer to Figure 4.5 for a plan and elevation view of the center pier, located in Appendix G.

4.2.5. Retaining Walls

4.2.5.1. Roadway Retaining Walls

The proposed concrete-encased beam structure type allows for a new bridge with the required minimum vertical clearance without the need to lower Canal Street. Without the need to re-grade Canal Street, impacts on existing retaining walls will be mitigated. An existing retaining wall on the east side of Canal Street south of the bridge will need to be removed due to the widening of Canal Street. A new retaining wall will need to be constructed in this vicinity along the proposed perimeter of the roadway to maintain a stable slope adjacent to the tracks.

No other new retaining walls will be required, and none of the other existing retaining walls will need to be reconstructed or underpinned.

4.2.5.2. Railroad Retaining Walls

An abandoned building on the southwest corner of the bridge will need to be removed. This building is integrated into the existing wingwall and currently aids in earth retaining. The proposed southern wingwall of the western abutment will be constructed adjacent to the tracks and will serve as the earth retaining structure for that corner.

On the northeast corner of the bridge, the existing retaining wall will be removed and replaced with the proposed wingwall for that respective abutment.

4.3. Phased Construction Requirements

Because only one track can be taken out of service at a time, the construction of a new bridge must be done in phases. The new construction will be a top-down method to allow the foundations of the nearby operating track to remain stable. The tracks can be taken out of service in a north to south or a south to north order. As previously discussed in the rail operations section of this report, the tracks are shown as being taken out from north to south. Please refer to Figure 4.3a through Figure 4.3d for the construction staging sequence, located in Appendix G.

As a track is taken out of service, work will immediately begin to stabilize the foundation of the adjacent tracks to permit excavation under the track that is out. Once the earth retaining system has been set in place, construction of the new abutments will begin in a top-down method. At the same time, the existing pier will be demolished under the track that is out and the new pier will be constructed in its proposed location. The new superstructure will be fully supported by new substructure with the existing, independently functioning structure one track away. Once the new structure is completed, the next adjacent track will be taken out of service. Again, care will be taken not to disturb the existing or new foundations.

Upon completion of the last track, the roadwork to realign the underpass roadway will begin its final stages. At this point, the existing abutments and the backfill between the existing and proposed abutment will be removed and excavated in conjunction with the top-down construction of the abutment tie-back walls.

4.3.1 Suggested Superstructure Erection Method

The conditions around the track present challenges for the erection procedure. Particular challenges include:

- obtaining the required vertical clearance
- horizontal clearances limited by adjacent live tracks
- maintenance of traffic
- overhead wires

A method of erection that is suited to these constraints is launching the girders on the out-of-service track. This involves the building of a beam erection frame on both the abutment and the pier at track level. These frames will support an erection beam that will span from pier to abutment and be capable of supporting at least one half the weight of a bridge beam. The bridge beam will be delivered to the site via rail car on the track that is out of service. One end of the bridge beam will be supported by rollers on the bottom flange of the erection beam while the other beam will be supported on land by another rolling mechanism. The bridge beam will be launched across the span and lowered to its permanent location. These steps will be repeated for all beams to complete the superstructure.

4.4. Aesthetic Treatments

The face of the concrete abutments will be aesthetically treated with concrete formliner to simulate a stone appearance and can be made to mimic the appearance of the original brownstone masonry.

4.5. Summary and Conclusions

4.5.1. Structure Summary

It is proposed that the existing single-span plate girder bridge be replaced as a two-span structure with one of the several proposed bridge types. A longer proposed span to accommodate additional travel lanes for the underpass will require the addition of a pier in order to minimize structure depth.

Five structure types were considered for feasibility. Non-viable types were eliminated and the remaining types were considered for impact to Canal Street alignment, constructability and cost.

One track will be taken out of service at a time, to mitigate impact to the rail operations. As a result, construction will progress in phases. Each phase will require a track outage where the existing bridge will be removed and reconstructed without disturbing the adjacent tracks which are to remain in operation. Because of the constraints presented, a top-down construction method is recommended to construct the abutments. For the purposes of this report, the tracks were replaced from north to south.

4.5.2. Construction Duration

The construction of the new undergrade bridge will be performed in seven phases. There will be one phase for each track since only one track can be taken out of service at a time. It is estimated that each track outage will require 150 calendar days to complete the necessary bridge reconstruction. The seven track outages and the five months needed to complete the roadway work for Canal Street add up to an estimated construction duration of 3 years, 10 months. Please refer to Appendix C for the construction schedule.

4.5.3. Estimated Construction Costs

Construction cost estimates have been developed based on the weighted unit prices listed in the Connecticut Department of Transportation's Item Master File (December 2010) and the CTDOT's Preliminary Cost Estimating Guidelines (January 2011). The cost estimates do not include costs associated with environmental studies, environmental remediation, rights-of-way acquisitions, or professional services for survey, design, or construction engineering and inspection. Please refer to Appendix D for the construction cost estimate details. The construction costs for the Canal Street site are summarized as follows:

Alternative 1: Concrete-Encased Steel Beams

Roadway, Drainage, Traffic and Structures	\$	27,477,000
Utilities	\$	110,000
Railroad	\$	7,647,000
Incidentals & Contingencies	\$	7,693,000
Total	\$	42,927,000

Alternative 2: Multi Steel Girders

Roadway, Drainage, Traffic and Structures	\$	23,311,000
Utilities	\$	110,000
Railroad	\$	6,453,000
Incidentals & Contingencies	\$	6,527,000
Total	\$	36,401,000

5. OTHER STRUCTURES

No other structures are proposed for Canal Street.

6. TRAFFIC

6.1. Traffic Operational Requirements

Canal Street is four-lane road that is classified as an Urban Collector. It provides two very narrow lanes in each direction as it passes under the MNR bridge. A major intersection with South State Street is located immediately to the north of the bridge, between the railroad and Interstate 95. Immediately east of this intersection is an eastbound entrance ramp to the Interstate. About 275 feet south of the bridge, Canal Street intersects Jefferson Street and Dock Street at a four-leg intersection that is the proposed site for the Stamford Urban Transitway.

In addition, North State Street intersects Canal Street just north of Interstate 95. The effect of these closely spaced, heavily utilized, signalized intersections is a condition where traffic flows are heavily impacted by both upstream and downstream operations. Queuing between these intersections can lead to congestion at adjoining locations even though the basic intersection capacity may theoretically be sufficient. Intersection signal timings, phasing and system coordination influence the operation and level of service within the entire corridor.

Existing capacity analyses show that all major intersections are at capacity during the peak hours of commuter traffic. Queue length, in many cases, exceed the available storage distances between intersection, adding to the congestion levels in the corridor.

Discussions with CTDOT and the City of Stamford led to the adoption of a cross section under the bridge that will provide better geometry, improved lane widths, and an additional northbound right turn lane approaching the North State Street intersection. This will provide an overall improvement to the levels of service provided, reduce queuing substantially, and reduce the levels of congestion in the corridor.

The revision to the Canal Street curb line under the MNR bridge and the modifications to the lane arrangements will require new signal head locations at the South State Street intersection. Because of the difficulties associated with the relocation of signal heads and wiring on an existing span wire assembly, it is likely that new signal poles, signals and wiring will be necessary. The new signal poles would likely follow Stamford's preference of using mast arm installations instead of span poles and wire. In addition, new vehicle detectors will be needed to accommodate the revised alignments and lane usage. It is potentially possible that the existing traffic signal controller could be maintained. A final determination of the viability of this alternate will be made during final design.

It appears that the traffic signal installations at the intersections of the SUT and North State Street can be maintained.

6.2. M&PT Requirements

Replacement of the bridge will be done one track at a time. The replacement work will require that each track be taken out of service while the reconstruction work on the bridge under that track is performed. The bridge replacement work can be done either working in the north to south, or the south to north direction.

The proposed cross-section of Canal Street under MNR will be comprised of three 11 foot lanes in the northbound direction with 2 foot shoulders, and two 11 foot lanes in the southbound direction with 2 foot shoulders, separated by an 8 foot wide median that will accommodate the bridge pier. An 8 foot wide sidewalk will be provided on both sides of Canal Street. The proposed horizontal alignment for Canal Street is similar to the existing layout. The vertical alignment on Canal Street will be determined by the bridge structure design, and will be a tangential/sag curve providing a minimum clearance of 14'-6" under the MNR bridge. Due to a decrease in superstructure depth with the new bridge, it will not be necessary to lower Canal Street, and this will reduce the impacts to South State Street and the I-95 northbound entrance ramp.

The southernmost lane of South State Street is expected to be closed throughout the construction duration to provide room for the reconstruction of the abutments and wing walls, demolition of the existing bridge, construction of the center pier and placement of bridge superstructure. Intermittent and longer duration lane closures on South State Street and the I-95 ramp may also be necessary to accomplish the necessary re-grading and reconstruction of those roadways.

Construction of the center-pier will significantly reduce the available space for maintaining traffic on Canal Street. In addition, utility relocations may be required by the pier construction and reconstruction of Canal Street, which may cause a significant disruption. The impacted utilities identified are:

- Low Pressure Gas (2)
- High Pressure Gas (2)
- Sanitary Sewer
- Water (3)
- Telephone
- Electric (Underground and Overhead)

Although the precise depths of these utilities are not known, it is assumed that the utilities may have to be relocated to accommodate the pier construction and/or lowered to accommodate the roadway reconstruction.

It is anticipated that two 10-foot lanes of traffic will be maintained, one in each direction. There will be 1-foot shoulders on both sides of Canal Street throughout the construction of the center pier and southbound roadway, and then shifted to the new southbound pavement during the reconstruction of the northbound roadway. The construction will be in two stages. Partial short-duration closures or lane reductions may be required to accomplish utility relocations. Please refer to Figures 6.1a and 6.1b for roadway maintenance and protection of traffic staging, located in Appendix G.

It should be noted that during the period that traffic is maintained on the existing roadway under the new bridge superstructure, vertical clearances will be severely limited. Alternate routes for trucks and emergency vehicles will need to be established.

Pedestrian detours will need to be developed whenever a sidewalk under a bridge is closed. Pedestrians should be directed to cross at the nearest signalized intersection on either side of the bridge. These detours will be developed during the final design stages.

7. DRAINAGE

7.1. Existing System Conditions

The existing Canal Street roadway profile has a low point near station 104+14 with contributing areas from station 101+97 and areas north of North State Street. From review of the latest available survey, existing runoff is collected in a series of catch basins east and west of Canal Street on North State Street and South State Street, as well as existing catch basins on Canal Street north of the intersection with North State Street. Please refer to Figure 7.1 for a plan view of the drainage system, located in Appendix G.

Near the I-95 crossing of Canal Street, survey indicates that the main trunkline servicing Canal Street and contributing areas is a 36-inch reinforced concrete pipe that conveys stormwater from the north to the south, however, this pipe is lost (on survey) in the vicinity of South State Street and the MNR crossing of Canal Street. Research

into the design of the SUT shows that this trunkline is actually a 48-inch RCP that takes a 45° bend south of the MNR crossing and continues beneath the MNR rail yard to the east of Canal Street. The pipe continues to its outlet at the northwest corner of the East Branch Canal through an existing stone rubble bulkhead. This discrepancy should be investigated during final design.

7.2. System Constraints

The design of the SUT incorporated a 42-inch RCP which runs west to east and outlets at the same location as the aforementioned 48-inch RCP. This pipe was found during field survey, though it is called out as a 40-inch pipe. An existing catch basin on Canal Street near station 101+00 LT connects to this pipe at a manhole in the intersection of the SUT and Canal Street with a 15-inch RCP (extrapolated station 99+68, 30'LT). There is no invert called out for this 15-inch RCP though the flow line of the 42-inch pipe is labeled at -4.3 feet (datum NAVD '88). The same manhole documented in the SUT drainage design computations is computed with an invert elevation of -2.4 feet (datum NGVD '29). In this area, the NAVD '88 datum is 1.1 feet lower than the NGVD '29 datum, making the designed elevation of this flow line -3.5 feet. Continuing on along this 42-inch pipe, the next survey located manhole indicates a flow line of -2.5 feet (datum NAVD '88), indicating that the flow is continuing from east to west. It is known from the design of the SUT and from field visits that the flow direction in this system is from west to east draining to the East Branch Canal. This discrepancy will have to be revisited for final design, however to complete this study, the flow line documented in the SUT drainage design computations is used.

To address the drainage at the low point in Canal Street, two catch basins are proposed at the low point (station 104+14). These two catch basins would be connected by a 15-inch pipe (0.5% slope) flowing west, then to a catch basin at the southwest corner of the intersection of Canal and South Main Streets. From here it is proposed to run a new pipe 365 feet southeast to tie in to the 42-inch pipe in the SUT with a new manhole as shown on Figure 7.1, located in Appendix G. Based on the SUT design computations and converted from NGVD '29 to NAVD '88, the flow line of this manhole would be -3.5 feet, and the invert of the proposed 15-inch pipe into the manhole would be at -1.25. This proposed system would address the runoff at the low point and provide independence from existing drainage contributions along Canal Street.

The design of the SUT system, that outlets at the East Branch Canal, had incorporated a tide gate at the manhole near the northeast corner of the intersection of Canal Street and the SUT. Though this manhole is not included with the base survey for this project, the bend in the existing 42-inch pipe provides evidence of its existence. When the outlet of this drainage system becomes submerged, the tide gate closes and contributing runoff is backed up in the system until the hydraulic grade line reaches a bypass pipe at John Street, which then will relieve the back up and direct additional flows to a pump station. The elevation of this bypass pipe is 1.59 feet (datum NAVD '88). For a worst

case scenario computation of the proposed system, the starting water surface elevation at the proposed manhole at the intersection of the SUT and Canal Street is 1.59 feet (datum NAVD '88), with the assumption that the pump station receiving the bypass flows will have the capacity to maintain the contribution.

7.3. Concepts Considered

The City of Stamford requires that the storm sewer design to accommodate a 25-year event. All other requirements for storm sewer design will adhere to the Connecticut Department of Transportation Drainage Manual. Specifically:

- low points will be analyzed for a 25-year event
- on-grade gutter flow spread will be one half of the travel lane at maximum
- sag condition gutter flow spread will be all but one lane width at maximum
- storm sewer design will address full flow (non-pressure) conditions

7.4. Design Criteria

Minimal grading is required on Canal Street to meet the required underclearance of the railroad bridge. All existing drainage features that are not in conflict with the proposed roadway layout are proposed to be maintained. With this, three catch basins are proposed as part of this study. Two on either side of the low point of Canal Street (station 104+14) and one at the southwest corner of the intersection of Canal Street with South Main Street. The independence of this system from adjacent systems near the MNR crossing and the I-95 crossing will be maintained due to the unverified flow patterns of those adjacent systems.

7.4.1. Gutter flow

Gutter flow to the low points has been calculated from best available information. Drainage areas which were delineated to the low point are preliminary and subject to final grading based on vertical profile. The area contributing to the sag point at station 104+14, 28' LT is estimated at 0.1 acre. Assuming a minimum time of concentration of 5 minutes for impervious surfaces returns a 25-year rainfall event of 6.7 ⁱⁿ/hr; this, along with an impervious runoff coefficient of 0.9, yields 0.6 cfs being directly contributed to this point. In addition, there was 1 cfs of bypass contributed from the area contributing to the on grade inlet at the south west corner of the intersection of Canal and South State Street. Gutter flow computation results at this sag point show a gutter flow depth of 0.16 feet and a spread of 8.25 feet (based on a 2% roadway cross slope) leaving more than one lane dry. The area contributing to the sag point at station 104+14, 32' RT is estimated at 0.65 acres and includes not only roadway area from South State Street, I-95 Northbound Entrance Ramp and a portion of Canal Street but also some of the I-95 embankment parallel with the on-ramp. For the combined pervious and impervious surfaces contributing, the runoff coefficient was estimated at 0.5, and the time of concentration was estimated at 10 minutes (minimum time for pervious contributing

areas). This resulted in a 25-year rainfall rate of 5.5 ⁱⁿ/_{hr}, which generated 1.79 cfs of runoff to the low point. Computed flow depth in the gutter was 0.18 feet and the spread, based on a 2% cross slope, was 8.91 feet. More than one lane of Canal Street (northbound) is left dry for the 25-yr event.

7.4.2. Pipe flow

Three catch basins are proposed to collect the drainage on Canal Street. These three inlets are interconnected and independent of any adjacent systems currently functioning along the corridor. It is proposed to tie these inlets to the 42-inch pipe constructed as part of the SUT. The pipes associated with this proposed system are 15-inch in diameter and were set with slopes no greater than 0.6%. In setting these pipes and slopes, two feet of cover is provided from the roadway surface. Where the proposed system ties into the SUT drainage system, the total flow in the system is 4.16 cfs, which is 77% of the available capacity.

7.4.3. Hydraulic Grade Line

The proposed system ties into an existing trunkline upstream of a flap gate which was designed to mitigate potential backwater effects of high water events from Long Island Sound. The potential worst case scenario for evaluation of the hydraulic grade line would be when the flap gate is closed and system flow is forced to back up to the bypass pipe located on John Street, which then directs system flow to a pump station. This bypass pipe invert is 1.59 feet (datum NAVD '88). Therefore 1.59 feet was used as the starting water surface elevation for the evaluation of the hydraulic grade line for the proposed pipes and inlets on Canal Street. Minimum calculated freeboard for this system was 1.75 feet.

7.5. Summary of Impacts and Proposed Improvements

There are minimal impacts expected due to the grading requirements on Canal Street to improve the vertical clearance of the bridge. The low point will be addressed by the inclusion of the proposed catch basins.

Through this study, it has been revealed that additional information will be required prior to commencing with final design. While this study does show that drainage can be adequately addressed, additional investigation may reveal a more economic solution.

8. UTILITIES

Since there will be no significant change in the vertical profile, there will be a reduced impact on utilities due to a vertical grade adjustments. There may however be impacts due to the roadway reconstruction and/or pier construction. Three utility poles will need to be relocated to accommodate the widening of the road. The City of Stamford has Con96 fiber communication cable mounted on the existing bridge, which will require relocation as part of the bridge replacement project. The utilities in the area of the project

are shown on Figure 8.1., located in Appendix G. The depth of these utilities are not known at this time, and if it is determined that underground facilities are affected, vertical depth information would be required to determine the limits of the actual relocations required.

9. GEOTECHNICAL

9.1 Summary of Subsurface Data

9.1.1 Regional Geology

Published geologic mapping indicates that the predominant natural surficial deposits within the project area are sand and gravel overlying sand overlying fines. The sand and gravel in this area is generally less than 20 feet thick, horizontally bedded and overlies thicker inclined beds of sand which in turn overlie thinly bedded fines of variable thickness. The underlying bedrock within the project site is mapped as principally Pumpkin Ground member of Harrison Gneiss, which is a gray to spotted, medium to coarse grained, foliated gneiss.

9.1.2. Pilot Borings

Three geotechnical borings were performed to preliminarily explore the subsurface conditions at the site. The approximate as-drilled pilot boring locations are shown on Figure 9.1, Canal Street Pilot Boring Program (located in Appendix G). Each geotechnical boring was located in the field by taping from existing site features and observed and logged during drilling. Boring logs are located in Appendix F.

The geotechnical boring depths ranged between about 11 and 64 feet below the existing ground surface at the respective locations. Representative soil samples were obtained continuously to a depth of at least 10 feet and at about 5-foot intervals thereafter. Samples were collected by split-barrel sampling procedures in general accordance with ASTM D 1586 and bedrock was cored at one location to confirm its depth, nature, and quality. An observation well was installed within one of the geotechnical borings to observe longer term groundwater levels.

9.1.3. Subsurface Conditions

The subsurface conditions as interpreted from the geotechnical borings generally consisted of asphalt or asphalt over concrete over either fill or sand over organic silt over sand and gravel over bedrock, which is consistent with published geologic data. The asphalt or asphalt and concrete encountered were less than 18 inches thick. A detailed description of the subsurface conditions encountered in each of the test borings is contained on the logs.

9.1.4. Soil

Fill immediately underlies the surficial materials described above at geotechnical boring B-2 and was at least 10 feet thick. The fill material was generally classified as very loose to dense fine to coarse sand with varying fractions of gravel, silt, brick, and glass.

Sand immediately underlies the surficial materials described above at geotechnical borings B-1 and B-3. The sand is approximately 8 feet thick and generally consists of loose to medium dense fine to coarse sand with varying fractions of silt and gravel.

Organic silt immediately underlies the fill or sand described above and is between approximately 4 and 11 feet thick. The organic silt generally consists of very soft to stiff organic silt with little to trace fine sand and little wood fibers.

Sand and gravel immediately underlies the organic silt and was at least 5 feet thick and up to 38 feet thick where fully penetrating the stratum. The sand and gravel was generally classified as medium dense to very dense, fine to coarse sand with varying fractions of gravel and silt.

Bedrock was observed below the sand and gravel at approximately 50 feet below the existing ground surface at geotechnical boring location B-1. At this location the bedrock generally consisted of fair quality, medium hard, slightly weathered, whitish gray, medium grained gneiss.

9.1.5. Groundwater

Groundwater was observed in observation well B-2 at a depth of approximately 9 feet below the existing ground surface. Fluctuations in the observed groundwater level occur due to variation in precipitation, temperature, and other factors different from those existing at the time the measurements were made.

9.2. Geotechnical Construction Issues

Based on the above bridge rehabilitation concepts, the primary geotechnical issues that are anticipated will be the following:

- Protection of active railroad operations and of the existing tracks is required.
- Protection of existing structures during construction. These structures include railroad catenary structures, overhead and underground utilities, buildings and retaining walls.

- Management and disposal of excavated materials. Since both abutments are being removed and replaced, mini-piles will be drilled and significant excavation of the embankment soils will be required. Drill spoils will have to be disposed of in accordance with State and Local requirements. Excavated soils may be able to be reused elsewhere on the project depending on the nature and quality of the materials. If not, they will have to be disposed of in accordance with State and Local requirements.

9.3. Foundation Recommendations

Based on the information available, drilled mini-piles are recommended for the support of the proposed abutments and pier. The drilled mini-piles will have a permanent casing installed to the top of bedrock and will develop their capacity in the underlying bedrock. A continuous reinforcing bar will be installed from the bottom of the rock socket to the top of the pile. The rock socket and casing would be filled with tremie placed grout.

The mini-piles will be designed to carry the required design loads in the rock socket and will be sized and reinforced appropriately to resist any other imposed loads (e.g. uplift, lateral, etc.). Based on preliminary design loads and subsurface conditions, it is estimated that rock socket lengths will be approximately 10 to 15 feet and overall mini-pile lengths will be approximately 75 to 90 feet for the center pier and abutments respectively.

10. ENVIRONMENTAL

10.1. Required Environmental Permits

Work activities proposed for Canal Street fall outside of any FEMA regulated Floodplain and Floodway; therefore, no Flood Management Certification is anticipated for the project. Please refer to Figure 10.1 for the 100-year FEMA floodplain, located in Appendix G.

The project site does fall within the Coastal Boundary indicating that a DEEP administered Coastal Area Management Permit (CAM) will be required.

Wetland impacts are not expected for this highly urban setting, consequently local or tidal wetland permitting is not anticipated.

The total project footprint is expected to be greater than 1 acre which will trigger the requirement for a DEEP administered General Permit for *Stormwater and Dewatering Wastewaters from Construction Activities*.

11. SUMMARY AND CONCLUSIONS

In order to accommodate the rising traffic demands within the City of Stamford and to open up north-south access, it is necessary to address the bottlenecking that occurs at the Metro North Railroad underpasses. Additional travel lanes will be added upon the reconstruction of the undergrade bridge. The proposed new underpass will provide two 8-foot sidewalks, two-foot shoulders, three 11-foot lanes traveling in the northbound direction and two 11-foot lanes traveling in the southbound direction.

The new structure will be comprised of two spans supported by abutments and a center pier. The depth of structure will depend upon the structure type that is selected. After careful consideration of several structure types for the study, four were eliminated as not being viable. Two structure types remain as possible options: the precast multi concrete-encased beams and the multi-steel girder ballasted steel plate deck option. Neither selection will require lowering Canal Street according to this preliminary analysis.

Impacts to rail operations will be minimized by only taking one Metro-North railroad track out of service at a time. A top-down methodology is recommended for construction of the abutments because of the restrictions on the track outages and the limited overhead access due to the catenaries. These abutments will be short stub abutments and founded on drilled mini-piles. The proposed piers will be cast in place and will be comprised of a footing, pier cap, and circular columns also founded on drilled mini-piles.

Throughout the construction process, Canal Street will remain open to traffic. Two travel lanes will be maintained, one in each direction.

APPENDIX A – HIGHWAY DESIGN CRITERIA

Canal Street is located in built-up areas with a design speed of 30 mph. Canal Street is classified as a Urban Collector according to the Connecticut Department of Transportation’s criterion for roadway design based on roadway classification.

Key design criteria are outlined in the table below.

Canal Street – Urban Collector			
Design Element		Recommended Design Value	Proposed Design Value
Design Speed		30 - 40 mph	30 mph
Travel Lane Width		10’-12’	11’
Shoulder Width	Right	2’ – 8’	2’
	Left	2’ – 8’	2’
Cross Slope		1.5 – 2.0% (1.5 – 3.0% w/ curbing)	2.0%
Turn Lane Width		11’	11’
Turn Lane Shoulder Width		2’ – 4’	2’
Sidewalk Width		5’ Minimum	8’
Bicycle Lane	Width	5’	N.A.
	Cross Slope	2.0%	N.A.
Roadside Clear zones		14’	10’
Stopping Sight Distance		200’	300’ ⁽²⁾
Intersection Sight Distance		355’	260’
Minimum radius (e=4.0%)		230’	230’
Superelevation Maximum		4.0%	None
Maximum Grade		11.0%	1.30% ⁽²⁾
Minimum Grade		0.5%	0.56% ⁽²⁾
Vertical Curvature (K-Value)	Crest	19	22 ⁽²⁾
	Sag	37	
Minimum Vertical Clearance Under New Bridge		14’-6’’ ⁽¹⁾	14’-6’’
Source: Figure 5E, Connecticut Department of Transportation Highway Design Manual, 2003 Edition			
(1) 14’-6’’ minimum vertical clearance used.			
(2) Existing Vertical Geometry values.			

APPENDIX B – BRIDGE DESIGN CRITERIA

- Structure Layout
 - Bridge will span over the proposed roadway cross section conforming to the City of Stamford requirements
 - Abutments will be located outside of proposed sidewalks
 - Pier is located between the northbound and southbound lanes
 - Substructure units will be parallel or tangent to the roadway baseline and parallel to each other

- Bridge Type
 - Superstructure
 - Bridge will consist of two simple spans supported on abutments and a pier
 - Primary replacement bridge choice will be Metro-North's preferred ballasted deck
 - Structure types considered:
 - Half-through Plate Girders
 - Two-Girder Ballasted Concrete Deck
 - Four-Girder Ballasted Steel Plate Deck
 - Multi Concrete-Encased Beams
 - Prestressed Butted Box Beams
 - Design considerations:
 - Girders are designed for strength
 - Girders also have a service criteria
 - Maximum deflection is equal to $L/640$
 - Structure type used for the purposes of this report is the multi concrete-encased beams
 - Access walkways will be provided for the purposes of servicing the tracks
 - Substructure
 - The abutments and the pier proposed are to be constructed using cast-in-place concrete. However, precast concrete modules will be considered for an accelerated construction schedule.
 - Foundation
 - The footing of the abutment will be founded on mini-piles

- Consideration will be given to using a spread footing at the center pier if a work area of proper width can be obtained given the constraints posed by M&PT. If a spread footing is not attainable, mini-piles will be used.

- Structure Depth
 - Structure depth is based on a top of rail elevation to bottom of beam depth and is based on the following assumptions:
 - Rail height – 7 5/8” (typ.)
 - Depth of Concrete Tie – 8.5” (typ.)
 - Depth of Ballast below railroad tie – 8.5” (typ.) bridge was designed for an additional 3.5” to be added in the future
 - Ballast Mat – 1” (typ.)
 - Concrete Deck with Haunch – 13” (specific to the 2-girder ballasted concrete deck structure type)
 - Steel Plate – 1.5” (specific to the 4-girder ballasted steel plate deck structure type)
 - Depth of Beam (this dimension is in addition to the previously mentioned items with the exception of the half-thru girder option. For the half-thru girder option, the structure depth is equivalent to the beam depth as the top flange is at the top of rail elevation.)

- Construction
 - Stage construction is based on single track outages
 - For the purposes of this report, tracks are taken out of service from north to south
 - Construction of the abutments will use a top-down methodology
 - Catenary wires will remain in place during construction and will be maintained and protected

- Rail Geometry
 - Existing horizontal and vertical alignment will be maintained

APPENDIX C – CONSTRUCTION SCHEDULE

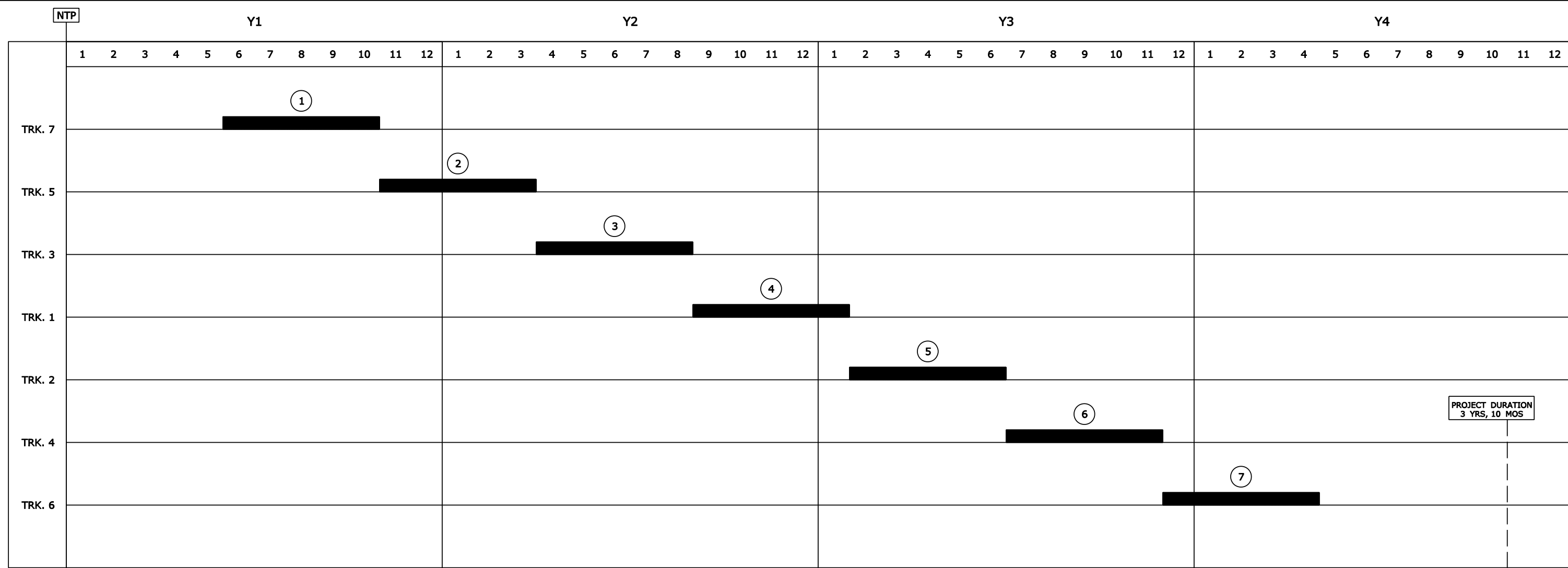

STAGE NO.	MOBILIZATION STAGE	1	2	3	4	5	6	7
CALENDAR DAYS	150	150	150	150	150	150	150	150

CANAL STREET (ROAD WORK)	REMOVE EX. ABUTMENTS
	INSTALL ROADWAY

LEGEND:

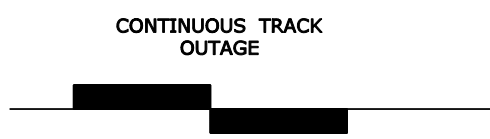

SOUTH STAMFORD ACCESSIBILITY & MNRR BRIDGE REPLACEMENT FEASIBILITY STUDY

CANAL STREET TRACK OUTAGE SCHEDULE

APPENDIX D – CONSTRUCTION COST ESTIMATES



South Stamford Accessibility and MNRR Bridge Replacement Feasibility Study

Stamford, Connecticut

State Project No. 135-301

**PRELIMINARY ENGINEERING CONSTRUCTION COST ESTIMATE
CANAL STREET**

Item No.	Description	Unit	Unit Price	Alternative 1		Alternative 2	
				Quantity	Price	Quantity	Price
				Two Span Top Down Concrete-Encased Steel Beams		Two Span Top Down Multi Steel Girders	
Highway & Traffic Items							
1.	Earth Excavation	CY	\$26.00	1,009	\$26,234.00	1,009	\$26,234.00
2.	Rock Excavation	CY	\$50.00	112	\$5,600.00	112	\$5,600.00
3.	Drainage; Pipe (15")	LF	\$60.00	504	\$30,240.00	504	\$30,240.00
4.	Drainage; Catch Basins	EA	\$2,800.00	3	\$8,400.00	3	\$8,400.00
5.	Manhole	EA	\$3,500.00	1	\$3,500.00	1	\$3,500.00
6.	Milling of Bituminous Concrete 0" - 4"	SY	\$8.00	183	\$1,464.00	183	\$1,464.00
7.	HMA - Superpave	T	\$105.00	447	\$46,935.00	447	\$46,935.00
8.	Processed Aggregate Base	T	\$45.00	447	\$20,115.00	447	\$20,115.00
9.	Subbase	T	\$35.00	509	\$17,815.00	509	\$17,815.00
10.	Temporary PCBC	LF	\$42.00	430	\$18,060.00	430	\$18,060.00
11.	Relocate TPCBC	LF	\$17.00	430	\$7,310.00	430	\$7,310.00
12.	PCBC (Vertical and "F" Shape)	LF	\$100.00	210	\$21,000.00	210	\$21,000.00
13.	Impact Attenuators	EA	\$25,000.00	2	\$50,000.00	2	\$50,000.00
14.	Curbing; Concrete	LF	\$30.00	230	\$6,900.00	230	\$6,900.00
15.	Concrete Sidewalk	SF	\$15.00	3,600	\$54,000.00	3,600	\$54,000.00
16.	Trafficperson (City/State Police Officer)	HR	\$75.00	700	\$52,500.00	700	\$52,500.00
17.	Roadway Lighting	LF	\$40.00	225	\$9,000.00	225	\$9,000.00
18.	Traffic Signals; New	EA	\$200,000.00	1	\$200,000.00	1	\$200,000.00
Section Sub-Total					\$579,073.00		\$579,073.00
Structures Items - Undergrade Bridge							
19.	Structure Excavation - Earth (Complete)	CY	\$90.00	8,300	\$747,000.00	8,300	\$747,000.00
20.	Ballast	CY	\$175.00	550	\$96,250.00	550	\$96,250.00
21.	Ballast Mat	SF	\$15.00	10,400	\$156,000.00	10,400	\$156,000.00
22.	Pervious Structure Backfill	CY	\$105.00	1,800	\$189,000.00	1,800	\$189,000.00
23.	Removal of Superstructure	LS	\$350,000.00	1	\$350,000.00	1	\$350,000.00
24.	Removal of Substructure	LS	\$440,000.00	1	\$440,000.00	1	\$440,000.00
25.	Tie-Back Wall	SF	\$400.00	6,220	\$2,488,000.00	6,220	\$2,488,000.00
26.	Steel-Laminated Elastomeric Bearings	CI	\$3.00	56,400	\$169,200.00	58,000	\$174,000.00
27.	Class "A" Concrete	CY	\$850.00	1,100	\$935,000.00	1,100	\$935,000.00
28.	Class "F" Concrete	CY	\$1,250.00	200	\$250,000.00	200	\$250,000.00
29.	Architectural Formliner	SY	\$400.00	280	\$112,000.00	280	\$112,000.00
30.	Deformed Steel Bars	LBS	\$1.60	130,000	\$208,000.00	130,000	\$208,000.00
31.	Structural Steel (Site No. 1)	LBS	\$3.25	0	\$0.00	1,705,700	\$5,543,525.00
32.	Precast Concrete Encased Steel Girders	LF	\$1,270.00	6,720	\$8,534,400.00	0	\$0.00
33.	Drilled Mini-Piles	EA	\$10,000.00	320	\$3,200,000.00	320	\$3,200,000.00
34.	Temporary Earth Retaining System	SF	\$50.00	1,380	\$69,000.00	1,380	\$69,000.00
35.	Temporary Earth Retaining System (RR)	SF	\$160.00	6,710	\$1,073,600.00	6,710	\$1,073,600.00
36.	Lead Health Protection Program	LS	\$100,000.00	1	\$100,000.00	1	\$100,000.00
Section Sub-Total					\$19,117,450.00		\$16,131,375.00
Project Sub-Total							
Highway & Traffic + Structure					\$19,696,523.00		\$16,710,448.00



South Stamford Accessibility and MNRR Bridge Replacement Feasibility Study

Stamford, Connecticut

State Project No. 135-301

PRELIMINARY ENGINEERING CONSTRUCTION COST ESTIMATE
CANAL STREET

Table with columns: Item No., Description, Unit, Unit Price, Quantity, Price, Quantity, Price. Includes sub-totals for Alternative 1 and Alternative 2.

Project Total
Project Sub-Total + Percentage Based Items

Utility Relocation Costs
1. Utility Relocation Est. \$110,000.00

Railroad Costs
1. RR Force Account Work 1&2 @ 40%

Incidentals and Contingencies (applied to Project Total)
1. Incidentals @ 18%
2. Contingencies @ 10%

Cost of Bridge Replacement (2011) \$42,927,091.47 \$36,400,725.95
SAY \$43,000,000.00 \$36,400,000.00

Inflation to Mid-Point of Construction
Price Adjustment (adjust to 2016) 5 years @ 5%

Cost of Bridge Replacement (2016) \$54,787,055.37 \$46,457,575.39
SAY \$54,800,000.00 \$46,500,000.00

Project Cost Escalation Footnotes:

- 1. Estimated construction cost shown above is based on 2011 prices.
2. Rate of construction cost escalation is estimated at 5% per year, per CTDOT Estimating Guidelines, calculated to the mid-point of construction, which is anticipated to be 2016 based on an anticipated 2014 start of construction. Accordingly, the cost escalation factor is 1.28.

NOTES:

- 1. MNRR Force Account value is based on 40% of the sum of the total structure work for the Undergrade Bridge + 25% minor items applied to the total structure work.
2. MNRR Force Account includes the cost of Metro North personnel and railroad work associated with the removal of the existing bridge and construction of the proposed bridge, including removal & replacement of railroad tracks, communications & signals, and catenary pole relocation where applicable.
3. Items NOT included in this estimate:
- Building Demolition / ROW acquisitions
- Environmental Remediation
- Environmental Studies (20% of Environmental Remediation Costs)

APPENDIX E – DRAINAGE CALCULATIONS

Hydraflow Storm Sewers Plan

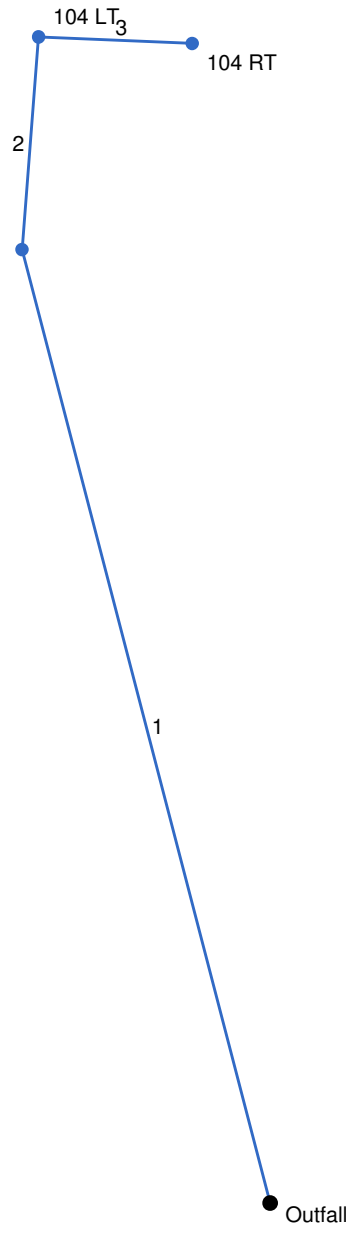

Inlet Report

Line No	Inlet ID	Q = CIA (cfs)	Q carry (cfs)	Q capt (cfs)	Q byp (cfs)	Junc type	Curb Inlet		Grate Inlet			Gutter						Inlet			Byp line No	
							Ht (in)	L (ft)	area (sqft)	L (ft)	W (ft)	So (ft/ft)	W (ft)	Sw (ft/ft)	Sx (ft/ft)	n	Depth (ft)	Spread (ft)	Depth (ft)	Spread (ft)		Depr (in)
1		2.12	0.00	1.07	1.06	Grate	4.0	4.00	3.13	1.64	3.15	0.005	2.00	0.020	0.020	0.013	0.20	10.10	0.20	10.10	0.0	2
2	104 LT	0.54	1.06	1.60	0.00	Grate	4.0	4.00	3.13	1.64	3.15	Sag	2.00	0.020	0.020	0.013	0.16	8.25	0.16	8.25	0.0	1
3	104 RT	1.79	0.00	1.79	0.00	Grate	4.0	4.00	3.13	1.64	3.15	Sag	2.00	0.020	0.020	0.013	0.18	8.91	0.18	8.91	0.0	2

Project File: CANAL DRAINAGE.stm

Number of lines: 3

Run Date: 09-17-2010

NOTES: Inlet N-Values = 0.016 ; Intensity = 101.98 / (Inlet time + 15.80) ^ 0.90; Return period = 25 Yrs. ; * Indicates Known Q added. All curb inlets are Horiz throat.

Storm Sewer Tabulation

Station		Len (ft)	Drng Area		Rnoff coeff (C)	Area x C		Tc		Rain (l) (in/hr)	Total flow (cfs)	Cap full (cfs)	Vel (ft/s)	Pipe		Invert Elev		HGL Elev		Grnd / Rim Elev		Line ID
Line	To Line		Incr (ac)	Total (ac)		Incr	Total	Inlet (min)	Syst (min)					Size (in)	Slope (%)	Dn (ft)	Up (ft)	Dn (ft)	Up (ft)	Dn (ft)	Up (ft)	
1	End	365	0.96	1.70	0.40	0.38	0.79	10.0	10.8	5.4	4.25	5.42	3.46	15	0.60	-1.25	0.94	1.59	2.94	5.82	5.54	
2	1	79	0.09	0.74	0.90	0.08	0.41	5.0	10.3	5.5	2.22	4.98	1.81	15	0.51	0.94	1.34	3.18	3.26	5.54	5.18	
3	2	57	0.65	0.65	0.50	0.33	0.33	10.0	10.0	5.5	1.79	4.99	1.46	15	0.51	1.34	1.63	3.35	3.39	5.18	5.07	

Project File: CANAL DRAINAGE.stm

Number of lines: 3

Run Date: 09-17-2010

NOTES: Intensity = 101.98 / (Inlet time + 15.80) ^ 0.90; Return period = 25 Yrs. ; c = cir e = ellip b = box

Hydraulic Grade Line Computations

Line	Size (in)	Q (cfs)	Downstream								Len (ft)	Upstream								Check		JL coeff (K)	Minor loss (ft)
			Invert elev (ft)	HGL elev (ft)	Depth (ft)	Area (sqft)	Vel (ft/s)	Vel head (ft)	EGL elev (ft)	Sf (%)		Invert elev (ft)	HGL elev (ft)	Depth (ft)	Area (sqft)	Vel (ft/s)	Vel head (ft)	EGL elev (ft)	Sf (%)	Ave Sf (%)	Enrgy loss (ft)		
1	15	4.25	-1.25	1.59	1.25	1.23	3.46	0.19	1.78	0.369	365	0.94	2.94	1.25	1.23	3.46	0.19	3.12	0.369	0.369	1.348	0.57	0.11
2	15	2.22	0.94	3.18	1.25	1.23	1.81	0.05	3.23	0.101	79	1.34	3.26	1.25	1.23	1.81	0.05	3.31	0.100	0.101	0.079	1.50	0.08
3	15	1.79	1.34	3.35	1.25	1.23	1.46	0.03	3.39	0.066	57	1.63	3.39	1.25	1.23	1.46	0.03	3.42	0.066	0.066	0.038	1.00	0.03

Project File: CANAL DRAINAGE.stm

Number of lines: 3

Run Date: 09-17-2010

; c = cir e = ellip b = box

APPENDIX F – BORING LOGS

		Connecticut DOT Boring Report		Hole No.: B-1
Inspector: R. Janeiro	Town: Stamford	Project No.: 0101-025.00		Stat./Offset:
Engineer: J. Kidd	Route No.:	Bridge No.:		Northing:
Start Date: 8-25-10			Easting:	
Finish Date: 8-25-10			Surface Elevation:	

Project Description: Canal Street, Pilot Boring Program

Casing Size/Type: 3"/NW	Sampler Type/Size: SS/1-3/8"	Core Barrel Type: NX
Hammer Wt.: 300 lb. Fall: 24in.	Hammer Wt.: 140 lb. Fall: 30 in.	

Groundwater Observations: @None observed

Depth (ft)	SAMPLES					Generalized Strata Description	Material Description and Notes	Elevation (ft)	
	Sample Type/No.	Blows on Sampler per 6 inches							Pen. (in.)
0							Asphalt		
							Concrete		
	S-1	9	6	5	10	24	13	Sand with Gravel & Silt	S-1: Medium dense, blackish gray fine to coarse SAND, some fine to coarse Gravel, some Silt, black staining throughout sample
5									
	S-2	5	7	8	4	24	3		S-2: Medium dense, brown fine to coarse SAND, little Silt, piece of coarse gravel in tip
	S-3	2	3	3	3	24	4		S-3: Loose, Top 2": brown fine to coarse SAND and fine to coarse Gravel
10								Organic Silt	Bottom 1": blackish brown ORGANICS, fibrous (odor)
	S-4	1	1	3	4	24	14		S-4: Soft, brown ORGANIC SILT, trace fine Sand, black staining top 3" of sample
	S-5	21	32	22	22	24	13		S-5: Top 5": Hard, blackish brown ORGANIC SILT, little fine to coarse Sand
15									Bottom 8": Very dense, gray fine to coarse GRAVEL, some fine to coarse Sand, trace Silt
	S-6	16	16	18	18	24	7		S-6: Dense, gray fine to coarse SAND, and Gravel, little Silt
20									
	S-7	10	12	11	9	24	11		S-7: Medium dense, gray fine to coarse SAND, and Gravel, trace Silt
25									

Sample Type: S = Split Spoon C = Core UP = Undisturbed Piston V = Vane Shear Test
 Proportions Used: Trace = 1 - 10%, Little = 10 - 20%, Some = 20 - 35%, And = 35 - 50%

Total Penetration in Earth: 54ft Rock: 10ft	NOTES: Drillers cored from 4.5' to 5.5' b.g.s (granite); Boring advanced open hole to 13.5' b.g.s, and started to used casing from 13.5' b.g.s; Auger chatter from 17' to 20', 28' to 30', 47' to 50', 52' to 54', 55' to 59'; Sand blew into casing (approx. 3') just before taking S-11, drillers refushed it out; Roller bit refusal at 54' b.g.s; 5' of blew in during casing placement from 52' to 54' b.g.s, which was drilled open hole; Drillers pull up rods after first core run due to blocking; Approx. 15' blow in prior to second core run, drillers rewash it out	Sheet 1 of 3
No. of Soil Samples: 13	No. of Core Runs: 2	SM-001-M REV. 1/02

		Connecticut DOT Boring Report		Hole No.: B-1
Inspector: R. Janeiro	Town: Stamford	Project No.: 0101-025.00		Stat./Offset:
Engineer: J. Kidd	Route No.:	Bridge No.:		Northing:
Start Date: 8-25-10			Easting:	
Finish Date: 8-25-10			Surface Elevation:	

Project Description: Canal Street, Pilot Boring Program

Casing Size/Type: 3"/NW	Sampler Type/Size: SS/1-3/8"	Core Barrel Type: NX
Hammer Wt.: 300 lb. Fall: 24in.	Hammer Wt.: 140 lb. Fall: 30 in.	

Groundwater Observations: @None observed

Depth (ft)	SAMPLES					Generalized Strata Description	Material Description and Notes	Elevation (ft)	
	Sample Type/No.	Blows on Sampler per 6 inches							Pen. (in.)
25	S-8	3	7	6	4	24	14		<p>S-8: Top 12": Medium dense, olive fine to coarse SAND, trace fine Gravel, trace Silt Bottom 2": Stiff, brownish gray SILT and CLAY, some fine to coarse Sand</p> <p>S-9: Medium dense, olive fine to coarse SAND and fine to coarse GRAVEL, trace Silt</p> <p>S-10: Medium dense, olive fine to coarse SAND, trace fine to coarse Gravel, trace Silt</p> <p>S-11: Medium dense, olive fine to coarse SAND, trace fine to coarse Gravel, trace Silt, (piece of coarse Gravel in tip of sample)</p> <p>S-12: Medium dense, brownish gray fine to medium SAND, some Silt, trace coarse Sand</p>
30	S-9	11	10	9	9	24	11		
35	S-10	8	9	8	9	24	13		
40	S-11	3	4	7	8	24	8		
45	S-12	5	5	7	9	24	16		
50									

Sample Type: S = Split Spoon C = Core UP = Undisturbed Piston V = Vane Shear Test
Proportions Used: Trace = 1 - 10%, Little = 10 - 20%, Some = 20 - 35%, And = 35 - 50%

Total Penetration in Earth: 54ft Rock: 10ft	NOTES: Drillers cored from 4.5' to 5.5' b.g.s (granite); Boring advanced open hole to 13.5' b.g.s, and started to used casing from 13.5' b.g.s; Auger chatter from 17' to 20', 28' to 30', 47' to 50', 52' to 54', 55' to 59'; Sand blew into casing (approx. 3') just before taking S-11, drillers refushed it out; Roller bit refusal at 54' b.g.s; 5' of blew in during casing placement from 52' to 54' b.g.s, which was drilled open hole; Drillers pull up rods after first core run due to blocking; Approx. 15' blow in prior to second core run, drillers rewash it out	Sheet 2 of 3
No. of Soil Samples: 13	No. of Core Runs: 2	SM-001-M REV. 1/02

		Connecticut DOT Boring Report		Hole No.: B-1
Inspector: R. Janeiro	Town: Stamford	Project No.: 0101-025.00		Stat./Offset:
Engineer: J. Kidd	Route No.:	Bridge No.:		Northing:
Start Date: 8-25-10			Easting:	
Finish Date: 8-25-10			Surface Elevation:	

Project Description: Canal Street, Pilot Boring Program

Casing Size/Type: 3"/NW	Sampler Type/Size: SS/1-3/8"	Core Barrel Type: NX
Hammer Wt.: 300 lb. Fall: 24in.	Hammer Wt.: 140 lb. Fall: 30 in.	

Groundwater Observations: @None observed

Depth (ft)	SAMPLES					Generalized Strata Description	Material Description and Notes	Elevation (ft)		
	Sample Type/No.	Blows on Sampler per 6 inches							Pen. (in.)	Rec. (in.)
50	S-13	10	24	62	47	24	14		Weathered Rock	S-13: Very dense, olive fine to coarse SAND, some fine to coarse Gravel, trace Silt, with rock fragments
55	C-1					60	12	7		
60	C-2					60	48	52		
65										END OF BORING 64ft
70										
75										

Sample Type: S = Split Spoon C = Core UP = Undisturbed Piston V = Vane Shear Test
 Proportions Used: Trace = 1 - 10%, Little = 10 - 20%, Some = 20 - 35%, And = 35 - 50%

Total Penetration in Earth: 54ft Rock: 10ft	NOTES: Drillers cored from 4.5' to 5.5' b.g.s (granite); Boring advanced open hole to 13.5' b.g.s, and started to used casing from 13.5' b.g.s; Auger chatter from 17' to 20', 28' to 30', 47' to 50', 52' to 54', 55' to 59'; Sand blew into casing (approx. 3') just before taking S-11, drillers refushed it out; Roller bit refusal at 54' b.g.s; 5' of blew in during casing placement from 52' to 54' b.g.s, which was drilled open hole; Drillers pull up rods after first core run due to blocking; Approx. 15' blow in prior to second core run, drillers rewash it out	Sheet 3 of 3
No. of Soil Samples: 13	No. of Core Runs: 2	SM-001-M REV. 1/02

		Connecticut DOT Boring Report		Hole No.: B-2 (OW)
Inspector: D. Lu	Town: Stamford	Project No.: 0101-025.00		Stat./Offset:
Engineer: J. Kidd	Route No.:	Bridge No.:		Northing:
Start Date: 9-7-10	Surface Elevation:			
Finish Date: 9-7-10	Project Description: Canal Street, Pilot Boring Program			

Casing Size/Type: 3"/NW	Sampler Type/Size: SS/1-3/8"	Core Barrel Type: NX
Hammer Wt.: 300 lb. Fall: 24in.	Hammer Wt.: 140 lb. Fall: 30 in.	

Groundwater Observations: @9 ft. after 0 hours

Depth (ft)	SAMPLES					Generalized Strata Description	Material Description and Notes	Well Construction	Elevation (ft)
	Sample Type/No.	Blows on Sampler per 6 inches							
0						Asphalt Concrete Fill			
1	S-1	12	18	15	9	24	11		
3	S-2	9	8	7	11	24	12		
5	S-3	9	5	7	6	24	7		
8	S-4	7	3	3	2	24	1		
10	S-5	2	1	1	1	24	14		
							END OF BORING 11ft		

Sample Type: S = Split Spoon C = Core UP = Undisturbed Piston V = Vane Shear Test
Proportions Used: Trace = 1 - 10%, Little = 10 - 20%, Some = 20 - 35%, And = 35 - 50%

Total Penetration in Earth: 11ft Rock: 0ft	NOTES: Drillers bore with SSA for sampling, and then overbore with HSA for well placement	Sheet 1 of 1
No. of Soil Samples: 5	No. of Core Runs: 0	SM-001-M REV. 1/02

		Connecticut DOT Boring Report				Hole No.: B-3		
Inspector: R. Janeiro		Town: Stamford		Stat./Offset:				
Engineer: J. Kidd		Project No.: 0101-025.00		Northing:				
Start Date: 8-26-10		Route No.:		Easting:				
Finish Date: 8-26-10		Bridge No.:		Surface Elevation:				
Project Description: Canal Street, Pilot Boring Program								
Casing Size/Type: 3"/NW		Sampler Type/Size: SS/1-3/8"			Core Barrel Type: NX			
Hammer Wt.: 300 lb. Fall: 24in.		Hammer Wt.: 140 lb. Fall: 30 in.						
Groundwater Observations: @None observed								
Depth (ft)	SAMPLES					Generalized Strata Description	Material Description and Notes	Elevation (ft)
	Sample Type/No.	Blows on Sampler per 6 inches						
0							Asphalt	
	S-1	16	18	24	13	24	16	Sand S-1: Dense, blackish gray fine to coarse SAND, some fine Gravel, little Silt, black staining throughout sample S-2: Medium dense, blackish gray Top 6": fine to coarse SAND, some fine to coarse Gravel, little Silt Bottom 6": fine to medium SAND, trace Silt, trace fine Gravel S-3: No recovery S-4: Loose, Top 6": brown fine to medium SAND, trace Silt, trace fine Gravel Bottom 6": dark gray fine to medium SAND and SILT, Organic odor S-5: Very soft, dark gray ORGANIC SILT, little wood fibers, Organic odor S-6: Medium stiff, dark gray ORGANIC SILT, little wood fibers, Organic odor S-7: Stiff, brown ORGANIC SILT, trace fine Sand, Little wood fibers, Organic odor
	S-2	9	10	12	9	24	12	
5	S-3	11	10	11	10	24	0	
	S-4	9	5	3	4	24	11	
	S-5	3	2	0	1	24	6	
	S-6	5	2	3	4	24	16	
10	S-7	7	6	7	9	24	24	
15								
20								
Sample Type: S = Split Spoon C = Core UP = Undisturbed Piston V = Vane Shear Test Proportions Used: Trace = 1 - 10%, Little = 10 - 20%, Some = 20 - 35%, And = 35 - 50%								
Total Penetration in		NOTES:						Sheet 1 of 2
Earth: 27ft Rock: 0ft								
No. of Soil Samples: 9		No. of Core Runs: 0						SM-001-M REV. 1/02

		Connecticut DOT Boring Report		Hole No.: B-3
Inspector: R. Janeiro	Town: Stamford	Project No.: 0101-025.00		Stat./Offset:
Engineer: J. Kidd	Route No.:	Bridge No.:		Northing:
Start Date: 8-26-10			Easting:	
Finish Date: 8-26-10			Surface Elevation:	

Project Description: Canal Street, Pilot Boring Program

Casing Size/Type: 3"/NW	Sampler Type/Size: SS/1-3/8"	Core Barrel Type: NX
Hammer Wt.: 300 lb. Fall: 24in.	Hammer Wt.: 140 lb. Fall: 30 in.	

Groundwater Observations: @None observed

Depth (ft)	SAMPLES					Generalized Strata Description	Material Description and Notes	Elevation (ft)		
	Sample Type/No.	Blows on Sampler per 6 inches							Pen. (in.)	Rec. (in.)
20	S-8	1	1	1	2	24	24		Organic Silt (cont)	S-8: Very soft, dark gray ORGANIC SILT, trace wood fibers, Organic odor
25	S-9	7	7	12	15	24	7			S-9: Medium dense, brown fine to coarse SAND, trace Silt
										END OF BORING 27ft
30										
35										
40										

Sample Type: S = Split Spoon C = Core UP = Undisturbed Piston V = Vane Shear Test
Proportions Used: Trace = 1 - 10%, Little = 10 - 20%, Some = 20 - 35%, And = 35 - 50%

Total Penetration in Earth: 27ft Rock: 0ft	NOTES:	Sheet 2 of 2
No. of Soil Samples: 9 No. of Core Runs: 0		SM-001-M REV. 1/02

APPENDIX G – FIGURES

Highway

- Figure 2.1 – Project Area
- Figure 2.2 – Roadway Plan
- Figure 2.3 – Roadway Profile
- Figure 2.4 – Roadway Cross Section

Rail Operations

- Figure 3.1a-g – Rail Staging and Sequencing Plans for Bridge 03678R

Bridge 03678R

- Figure 4.1 – General Plan & Elevation
- Figure 4.2 – Typical Sections
- Figure 4.3a-d – Construction Staging Sections
- Figure 4.4 – Abutments
- Figure 4.5 – Pier

Traffic

- Figure 6.1a-b – Maintenance and Protection of Traffic

Drainage

- Figure 7.1 – Drainage Plan

Utilities

- Figure 8.1 – Utility Plan

Geotechnical

- Figure 9.1 – Pilot Boring Plan

Environmental

- Figure 10.1 – 100-Year FEMA Floodplain

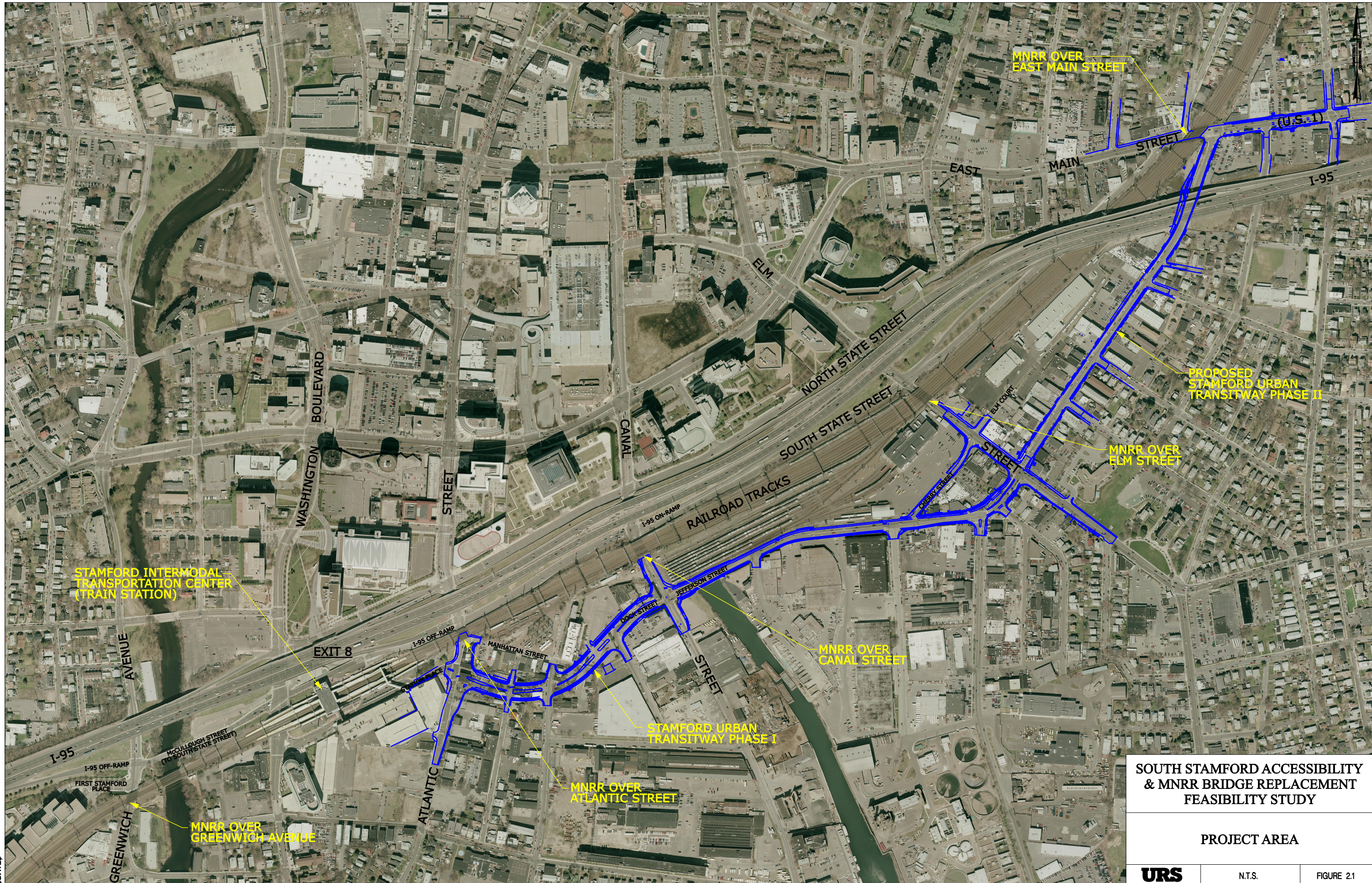

SOUTH STAMFORD ACCESSIBILITY & MNRR BRIDGE REPLACEMENT FEASIBILITY STUDY

PROJECT AREA

URS

N.T.S.

FIGURE 2.1

FILES
DATES

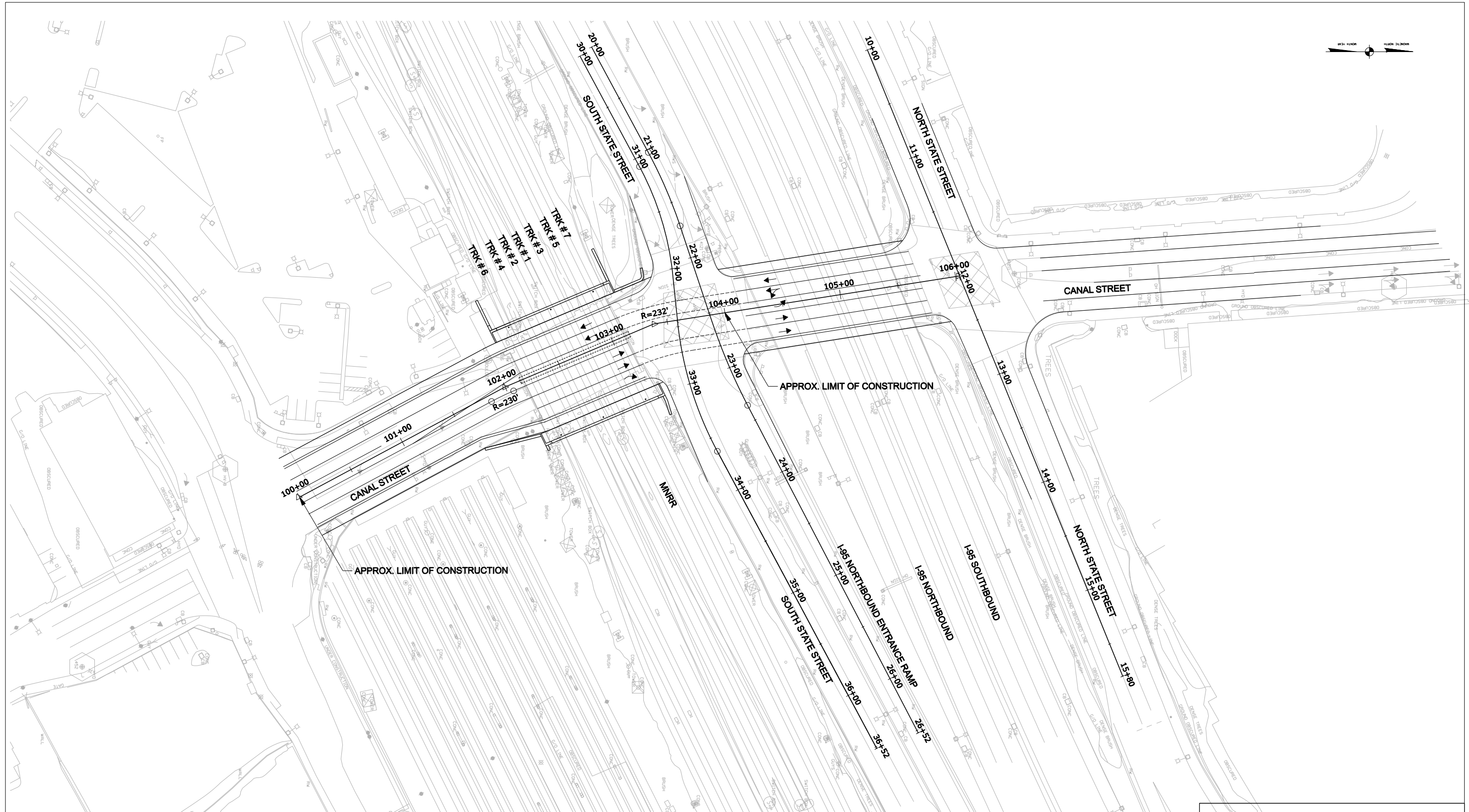

P:\CTDOT_projects\135-301\Highways\Phase-2\Canal\MSta_Contract_Sheet_Files\HW_MSH_135-301_PLN_CANAL.dgn
 10/13/2010

**SOUTH STAMFORD ACCESSIBILITY
 & MNRR BRIDGE REPLACEMENT
 FEASIBILITY STUDY**

**CANAL STREET
 ROADWAY PLAN**

URS

SCALE 1" = 80'

FIGURE 2.2

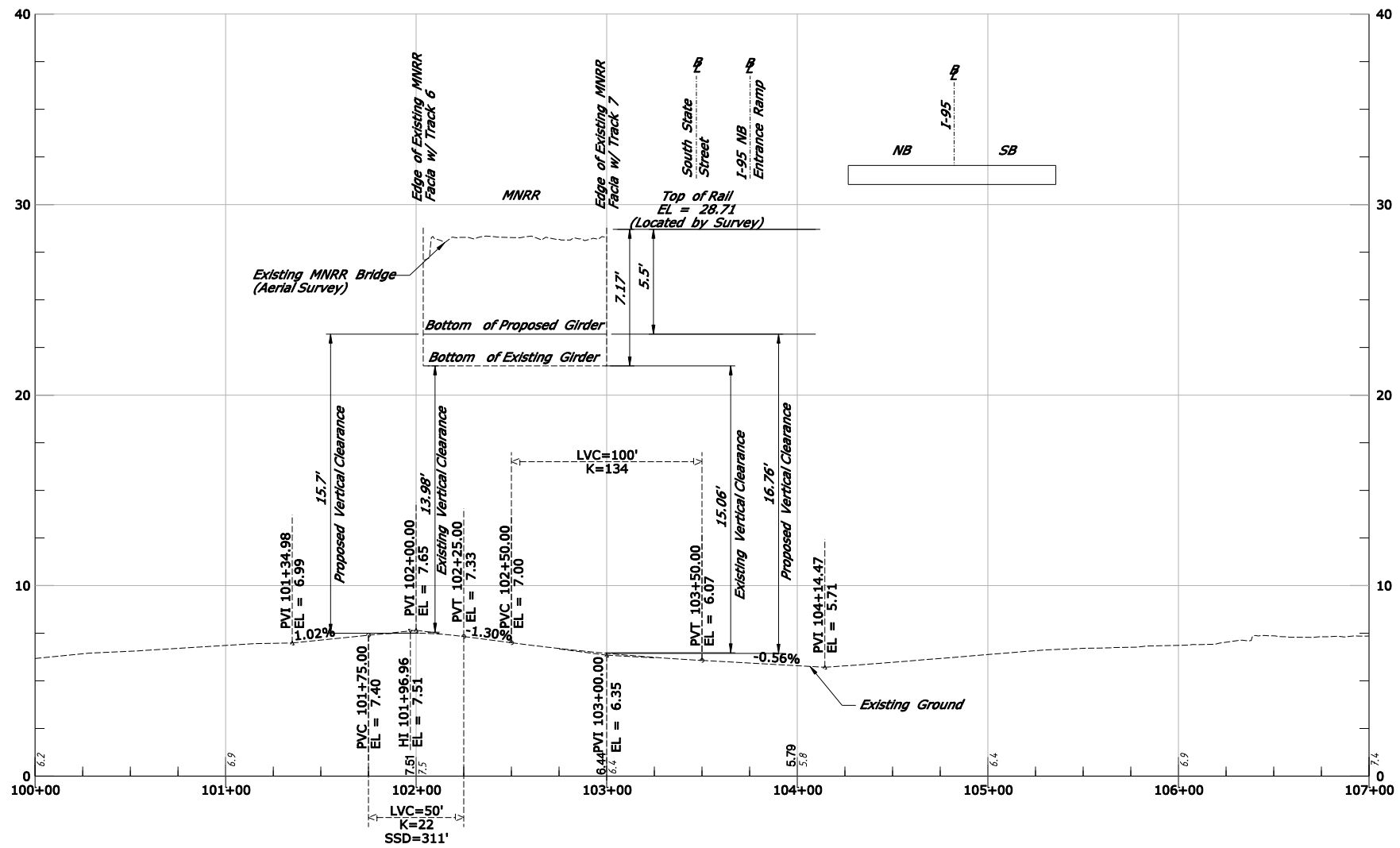

SOUTH STAMFORD ACCESSIBILITY
 & MNRR BRIDGE REPLACEMENT
 FEASIBILITY STUDY

CANAL STREET
 ROADWAY PROFILE

URS

SCALE 1"=80'

FIGURE 2.3

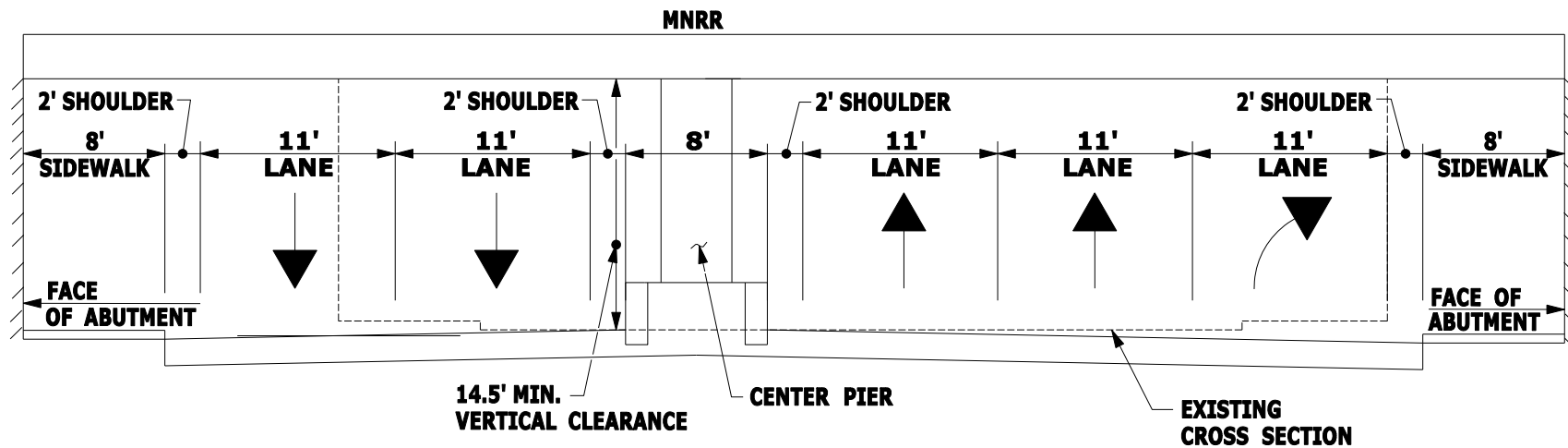

CANAL STREET LOOKING NORTHBOUND

SOUTH STAMFORD ACCESSIBILITY
& MNRR BRIDGE REPLACEMENT
FEASIBILITY STUDY

CANAL STREET
ROADWAY CROSS SECTION

URS

SCALE: 1"=10'

FIGURE 2.4

LEGEND:

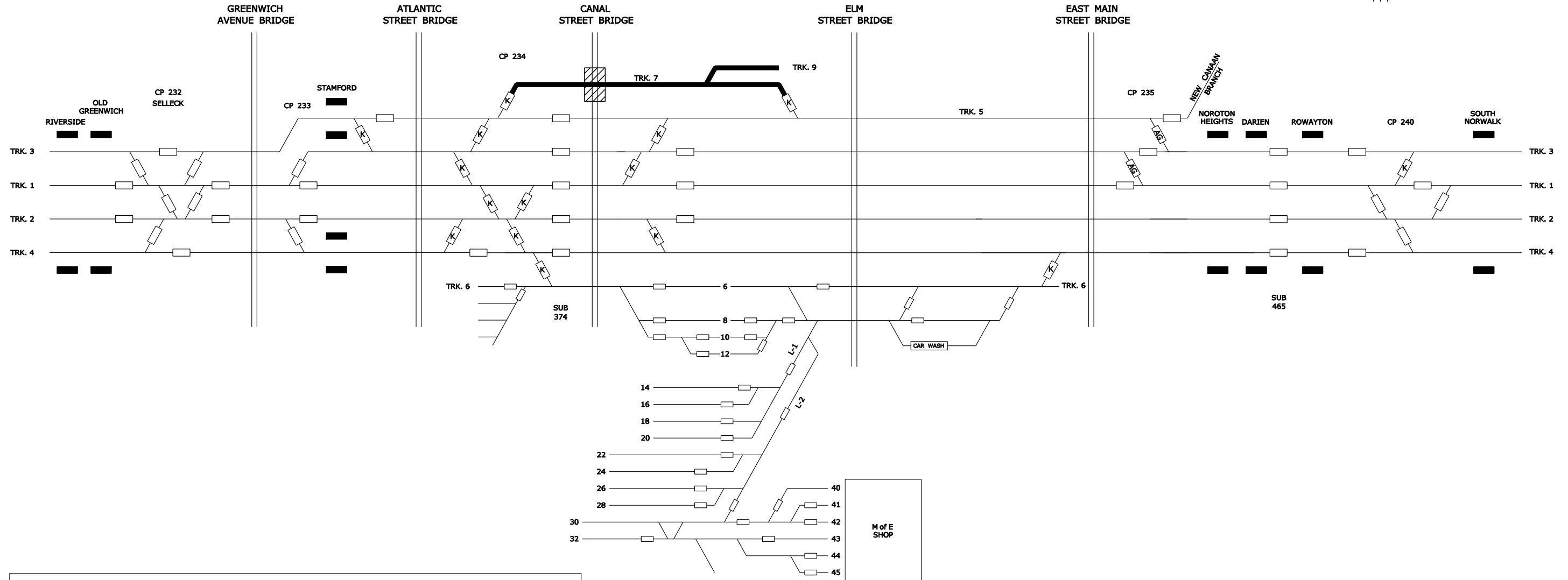
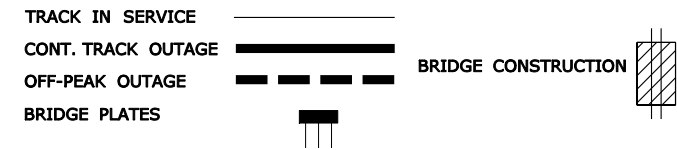

STAGE	TASK	TRACK	TRACK OUTAGE
1	1) REMOVE TRACK 7 AT CANAL ST. 2) REMOVE EXISTING STEEL SUPERSTRUCTURE 3) INSTALL NEW ABUTMENTS 4) INSTALL NEW CENTER PIER 5) CUT BACK TOPS OF EXISTING ABUTMENTS 6) INSTALL NEW SUPERSTRUCTURE 7) INSTALL NEW TRACK 7 AT CANAL ST.	7, 9	CONTINUOUS TRACK OUTAGE

SOUTH STAMFORD ACCESSIBILITY & MNRR BRIDGE REPLACEMENT FEASIBILITY STUDY

CANAL STREET CONSTRUCTION STAGING

STAGE 1

LEGEND:

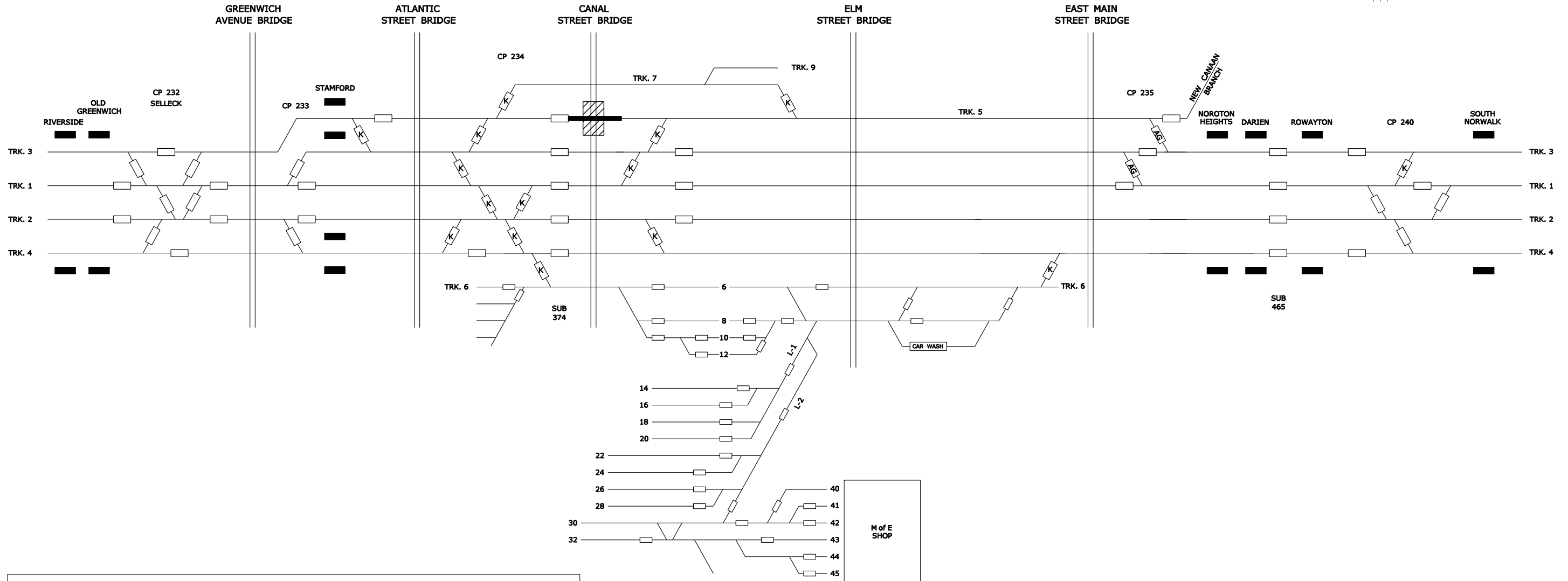
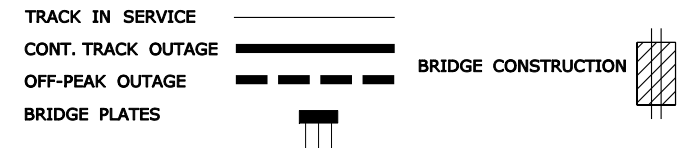

STAGE	TASK	TRACK	TRACK OUTAGE
2	1) REMOVE TRACK 5 AT CANAL ST. 2) REMOVE EXISTING STEEL SUPERSTRUCTURE 3) INSTALL NEW ABUTMENTS 4) INSTALL NEW CENTER PIER 5) CUT BACK TOPS OF EXISTING ABUTMENTS 6) INSTALL NEW SUPERSTRUCTURE 7) INSTALL NEW TRACK 5 AT CANAL ST.	5	CONTINUOUS TRACK OUTAGE

**SOUTH STAMFORD ACCESSIBILITY
& MNRR BRIDGE REPLACEMENT
FEASIBILITY STUDY**

**CANAL STREET
CONSTRUCTION STAGING**

STAGE 2

URS

SCALE: N.T.S.

FIGURE 3.1b

LEGEND:

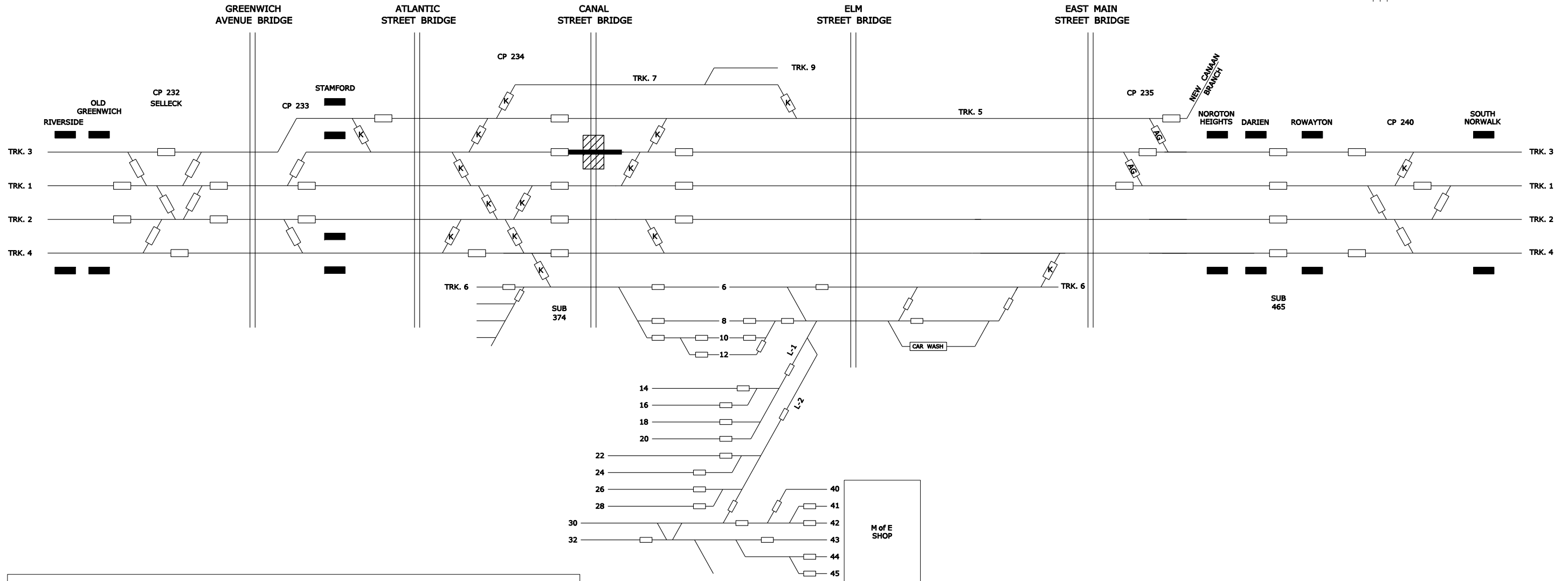
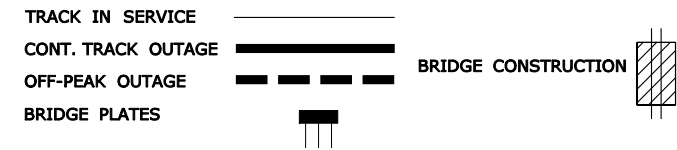

STAGE	TASK	TRACK	TRACK OUTAGE
3	1) REMOVE TRACK 3 AT CANAL ST. 2) REMOVE EXISTING STEEL SUPERSTRUCTURE 3) INSTALL NEW ABUTMENTS 4) INSTALL NEW CENTER PIER 5) CUT BACK TOPS OF EXISTING ABUTMENTS 6) INSTALL NEW SUPERSTRUCTURE 7) INSTALL NEW TRACK 3 AT CANAL ST.	3	CONTINUOUS TRACK OUTAGE

**SOUTH STAMFORD ACCESSIBILITY
& MNRR BRIDGE REPLACEMENT
FEASIBILITY STUDY**

**CANAL STREET
CONSTRUCTION STAGING**

STAGE 3

URS

SCALE: N.T.S.

FIGURE 3.1c

LEGEND:

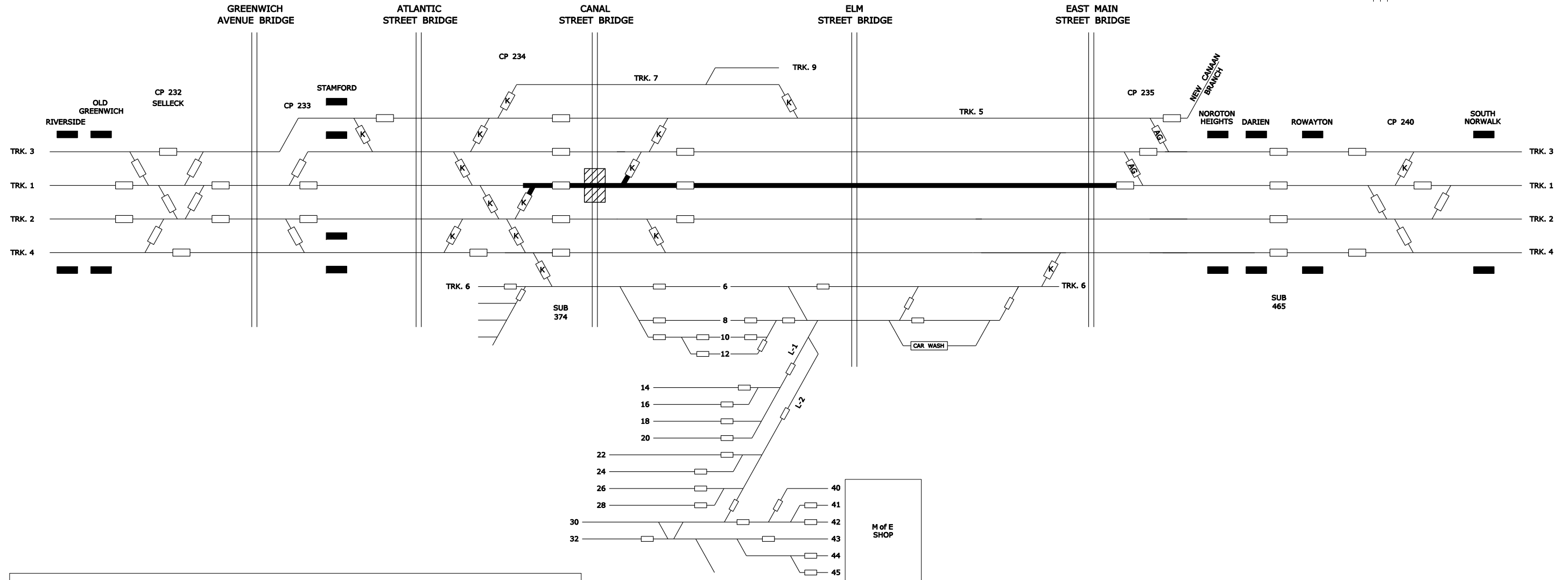
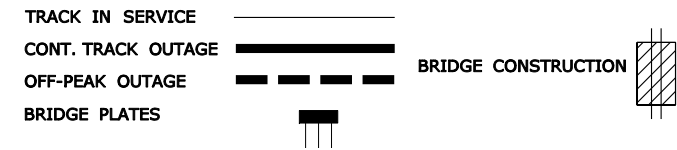

STAGE	TASK	TRACK	TRACK OUTAGE
4	1) REMOVE TRACK 1 AT CANAL ST. 2) REMOVE EXISTING STEEL SUPERSTRUCTURE 3) INSTALL NEW ABUTMENTS 4) INSTALL NEW CENTER PIER 5) CUT BACK TOPS OF EXISTING ABUTMENTS 6) INSTALL NEW SUPERSTRUCTURE 7) INSTALL NEW TRACK 1 AT CANAL ST.	1	CONTINUOUS TRACK OUTAGE

SOUTH STAMFORD ACCESSIBILITY
& MNRR BRIDGE REPLACEMENT
FEASIBILITY STUDY

CANAL STREET
CONSTRUCTION STAGING

STAGE 4

URS

SCALE: N.T.S.

FIGURE 3.1d

LEGEND:

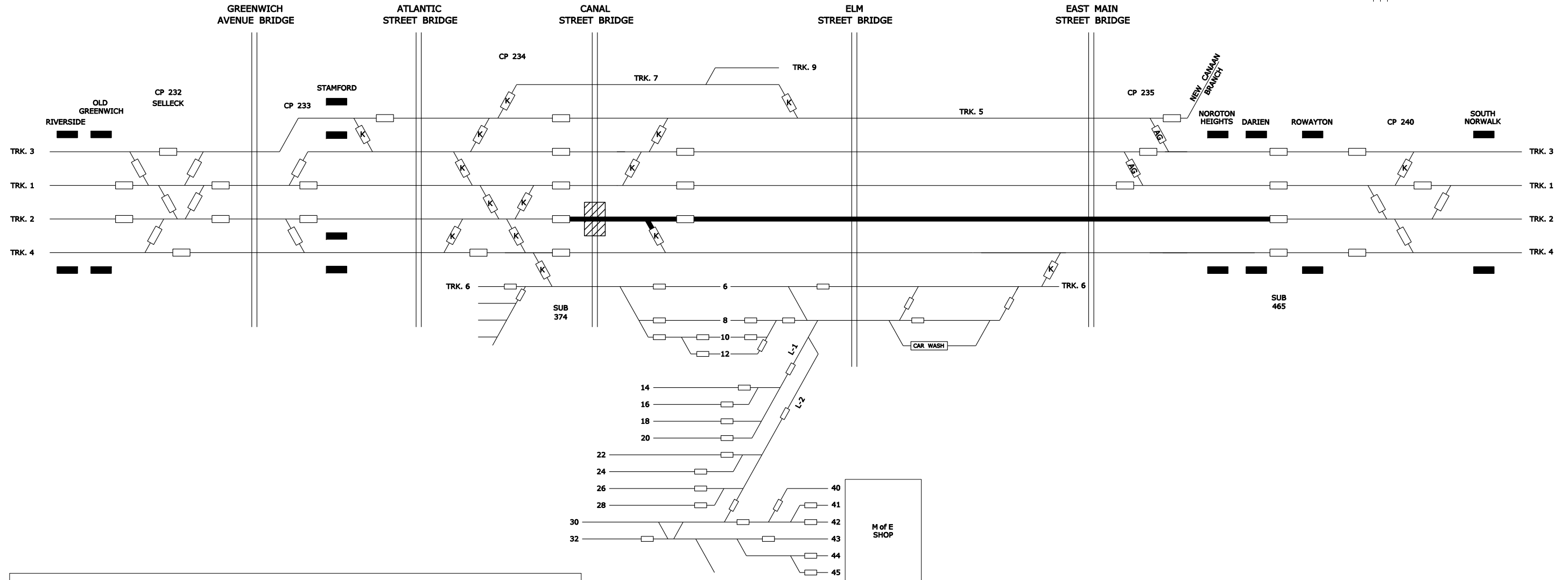
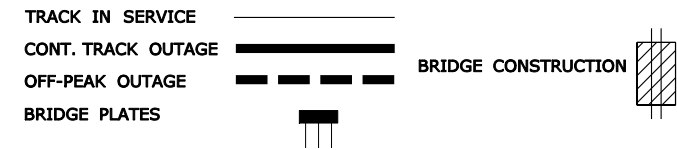

STAGE	TASK	TRACK	TRACK OUTAGE
5	1) REMOVE TRACK 2 AT CANAL ST. 2) REMOVE EXISTING STEEL SUPERSTRUCTURE 3) INSTALL NEW ABUTMENTS 4) INSTALL NEW CENTER PIER 5) CUT BACK TOPS OF EXISTING ABUTMENTS 6) INSTALL NEW SUPERSTRUCTURE 7) INSTALL NEW TRACK 2 AT CANAL ST.	2	CONTINUOUS TRACK OUTAGE

**SOUTH STAMFORD ACCESSIBILITY
& MNRR BRIDGE REPLACEMENT
FEASIBILITY STUDY**

**CANAL STREET
CONSTRUCTION STAGING**

STAGE 5

URS

SCALE: N.T.S.

FIGURE 3.1e

LEGEND:

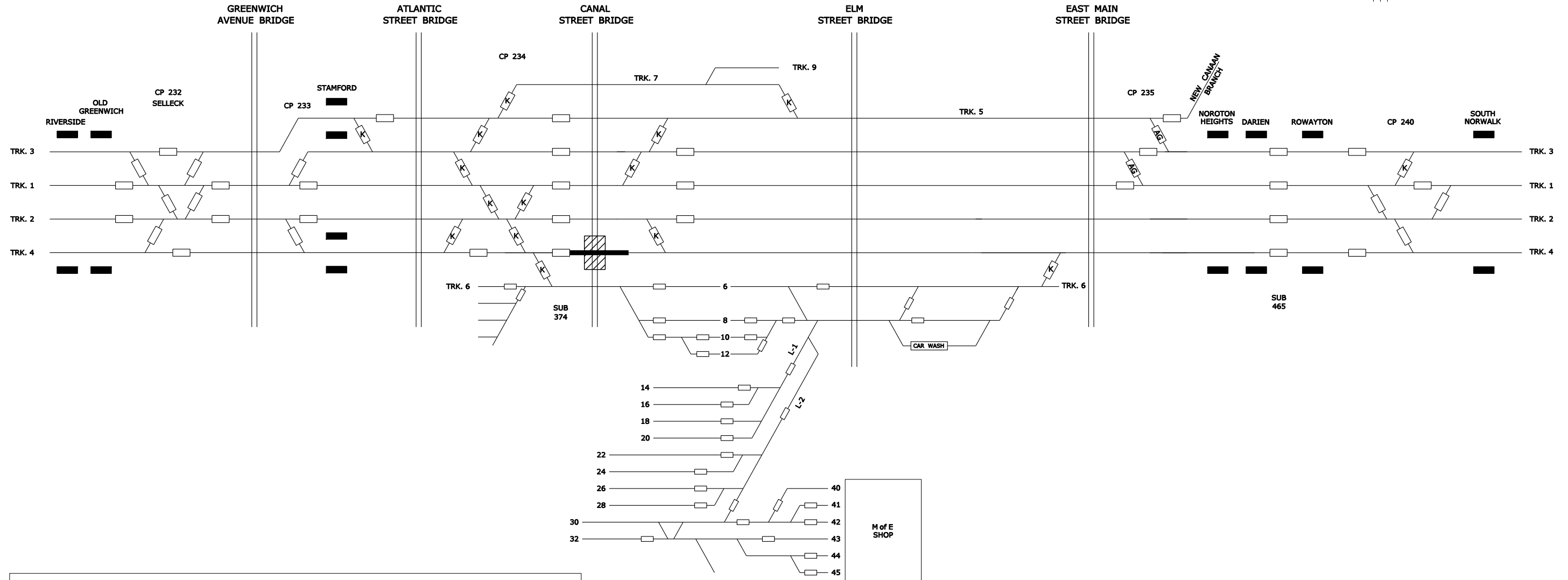
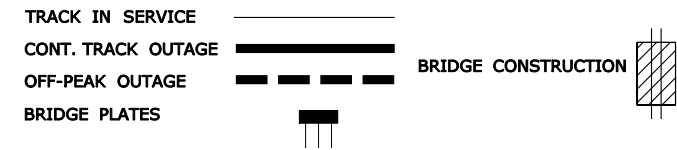

STAGE	TASK	TRACK	TRACK OUTAGE
6	1) REMOVE TRACK 4 AT CANAL ST. 2) REMOVE EXISTING STEEL SUPERSTRUCTURE 3) INSTALL NEW ABUTMENTS 4) INSTALL NEW CENTER PIER 5) CUT BACK TOPS OF EXISTING ABUTMENTS 6) INSTALL NEW SUPERSTRUCTURE 7) INSTALL NEW TRACK 4 AT CANAL ST.	4	CONTINUOUS TRACK OUTAGE

**SOUTH STAMFORD ACCESSIBILITY
& MNRR BRIDGE REPLACEMENT
FEASIBILITY STUDY**

**CANAL STREET
CONSTRUCTION STAGING**

STAGE 6

URS

SCALE: N.T.S.

FIGURE 3.1f

LEGEND:

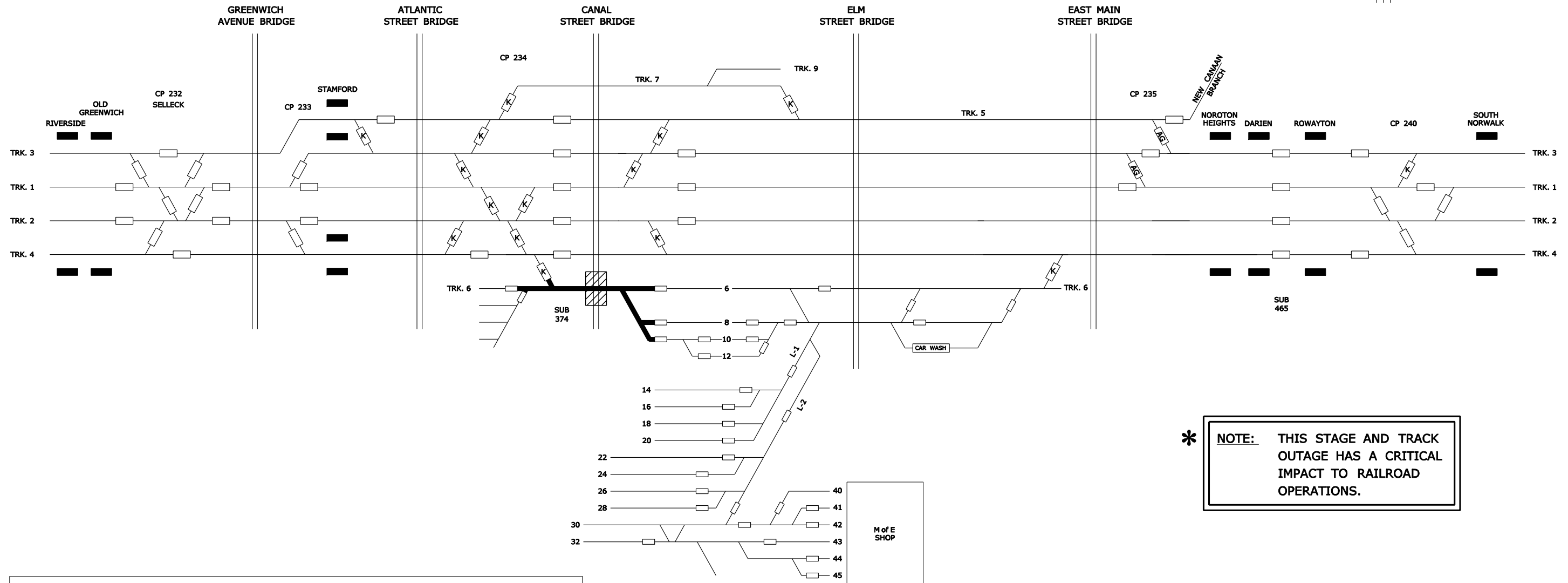
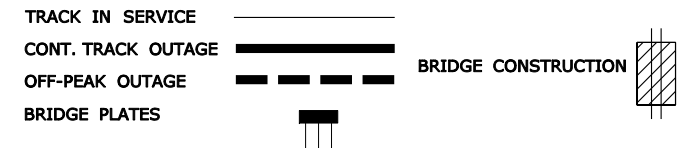

*** NOTE:** THIS STAGE AND TRACK OUTAGE HAS A CRITICAL IMPACT TO RAILROAD OPERATIONS.

STAGE	TASK	TRACK	TRACK OUTAGE
7	1) REMOVE TRACK 6 AT CANAL ST. 2) REMOVE EXISTING STEEL SUPERSTRUCTURE 3) INSTALL NEW ABUTMENTS 4) INSTALL NEW CENTER PIER 5) CUT BACK TOPS OF EXISTING ABUTMENTS 6) INSTALL NEW SUPERSTRUCTURE 7) INSTALL NEW TRACK 6 AT CANAL ST.	6	CONTINUOUS TRACK OUTAGE *

SOUTH STAMFORD ACCESSIBILITY & MNRR BRIDGE REPLACEMENT FEASIBILITY STUDY

CANAL STREET CONSTRUCTION STAGING

STAGE 7

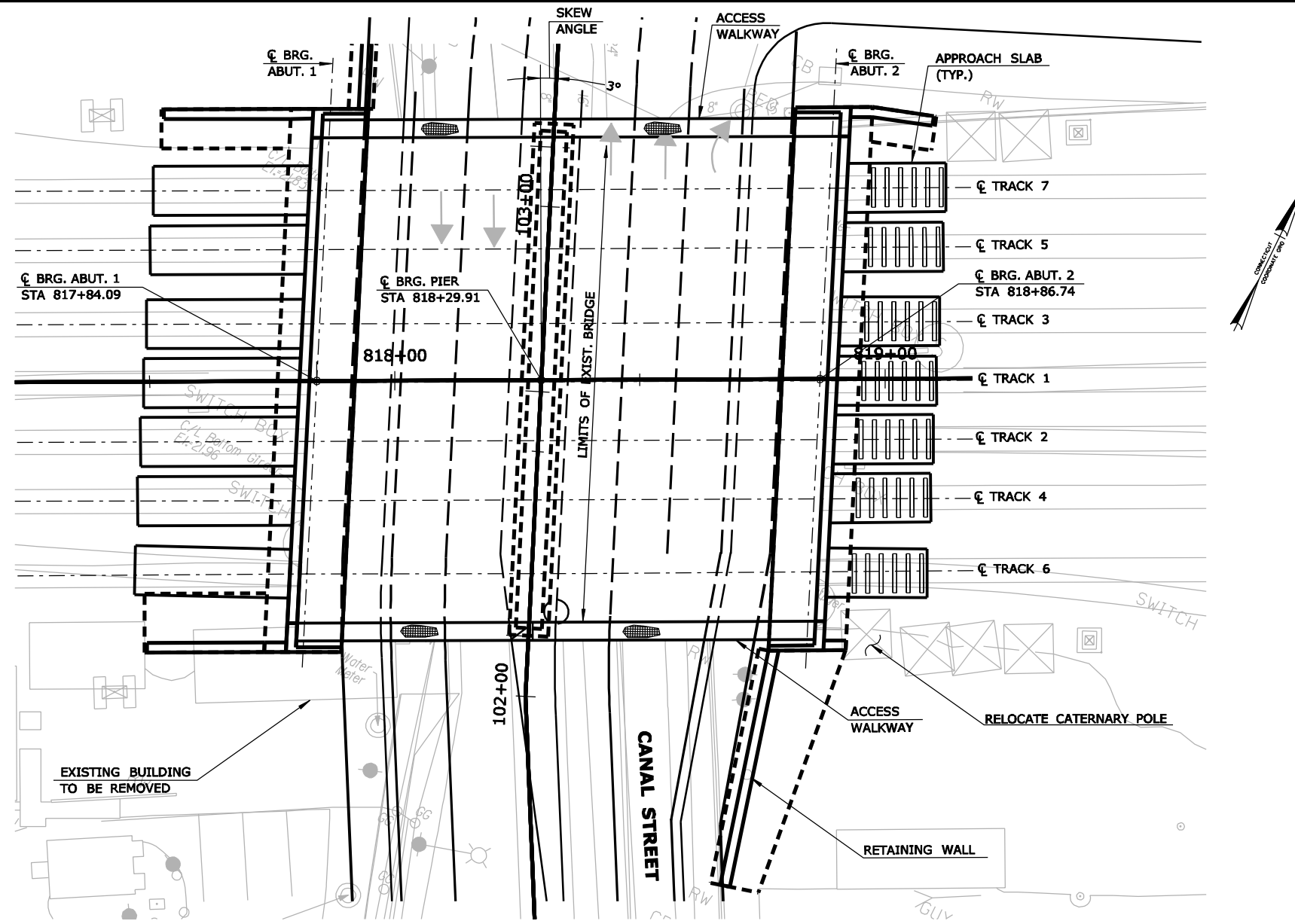

PROPOSED PLAN
SCALE: 1" = 30'

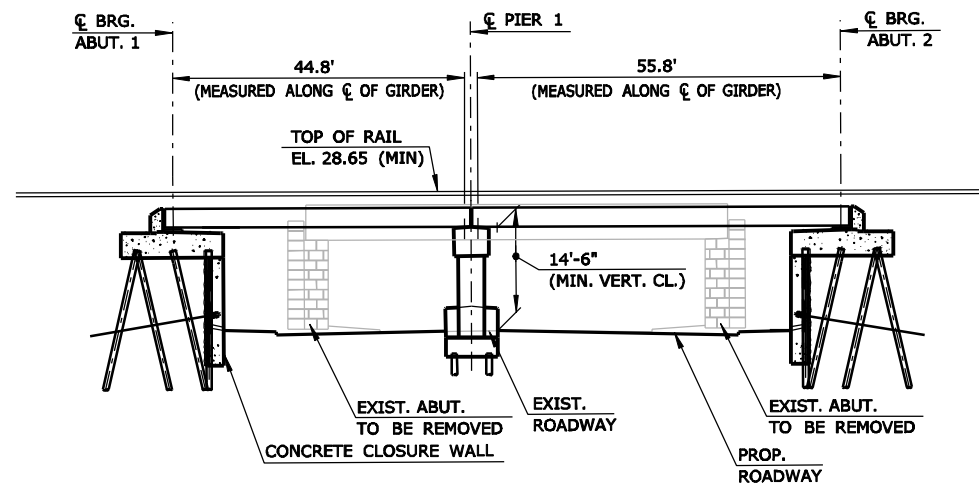

ELEVATION
SCALE: 1" = 30'

SOUTH STAMFORD ACCESSIBILITY & MNRR BRIDGE REPLACEMENT FEASIBILITY STUDY		
CANAL STREET GENERAL PLAN AND ELEVATION		
URS	SCALE AS NOTED	FIGURE 4.1

p:\ctdot_projects\135-301\struct_bridge\canal_st\msta_sheet_files\canal_st - General Plan & Elev.dgn 3/3/2011

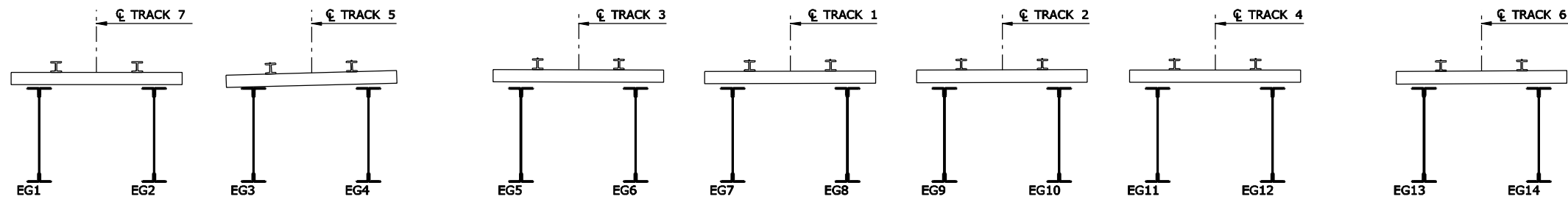

EXISTING SECTION - CANAL STREET

SCALE: 1/8" = 1'-0"

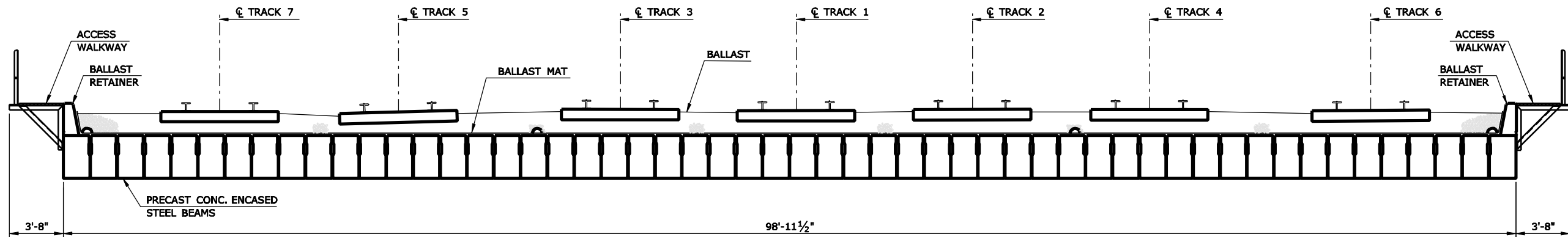

PRECAST MULTIPLE CONCRETE ENCASED STEEL GIRDERS

SCALE: 1/8" = 1'-0"

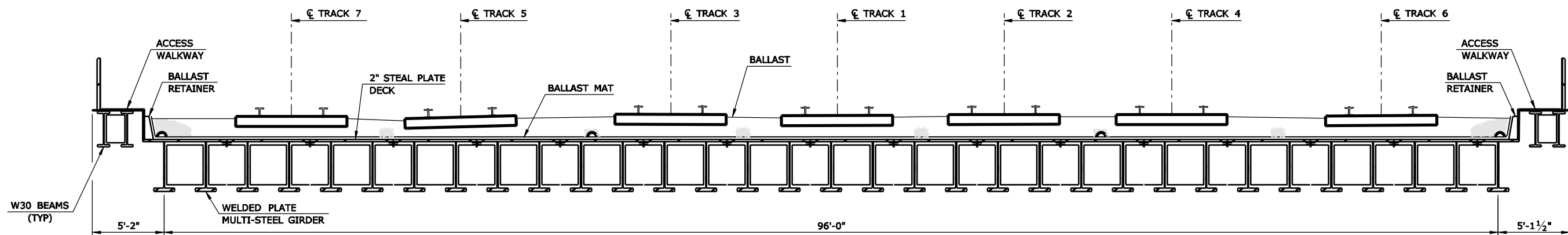

MULTI-STEEL GIRDERS

SCALE: 1/8" = 1'-0"

SOUTH STAMFORD ACCESSIBILITY
& MNRR BRIDGE REPLACEMENT
FEASIBILITY STUDY

CANAL STREET
TYPICAL SECTIONS

URS

SCALE AS NOTED

FIGURE 4.2

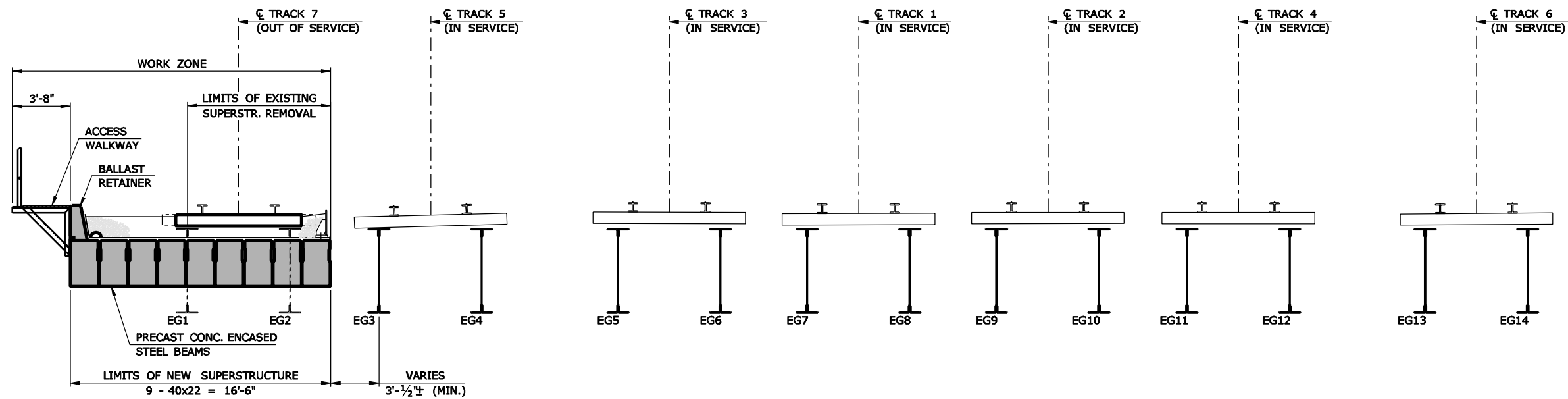

STAGE 1

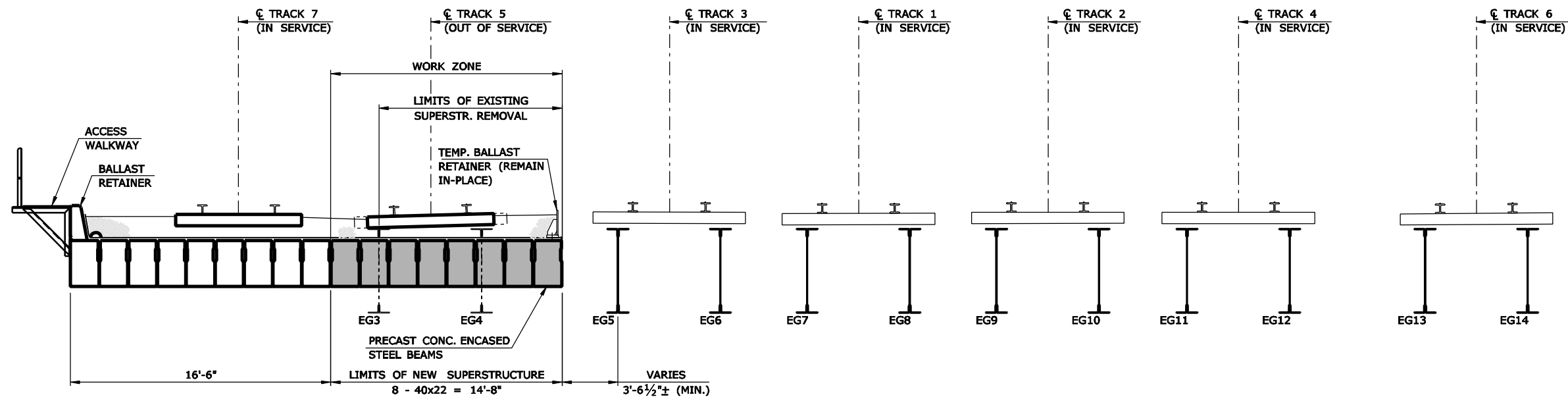

STAGE 2

STAGE CONSTRUCTION - PRECAST MULTIPLE CONCRETE ENCASED STEEL GIRDERS

SCALE: 1/8" = 1'-0"

SOUTH STAMFORD ACCESSIBILITY
& MNRR BRIDGE REPLACEMENT
FEASIBILITY STUDY

CANAL STREET
CONSTRUCTION STAGING SECTION

URS

SCALE AS NOTED

FIGURE 4.3A

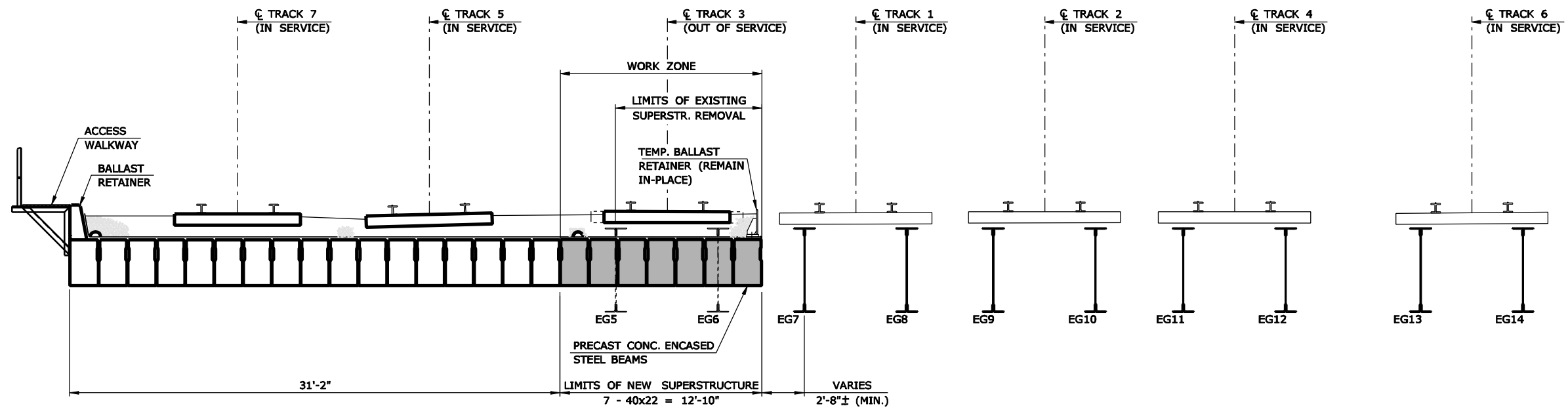

STAGE 3

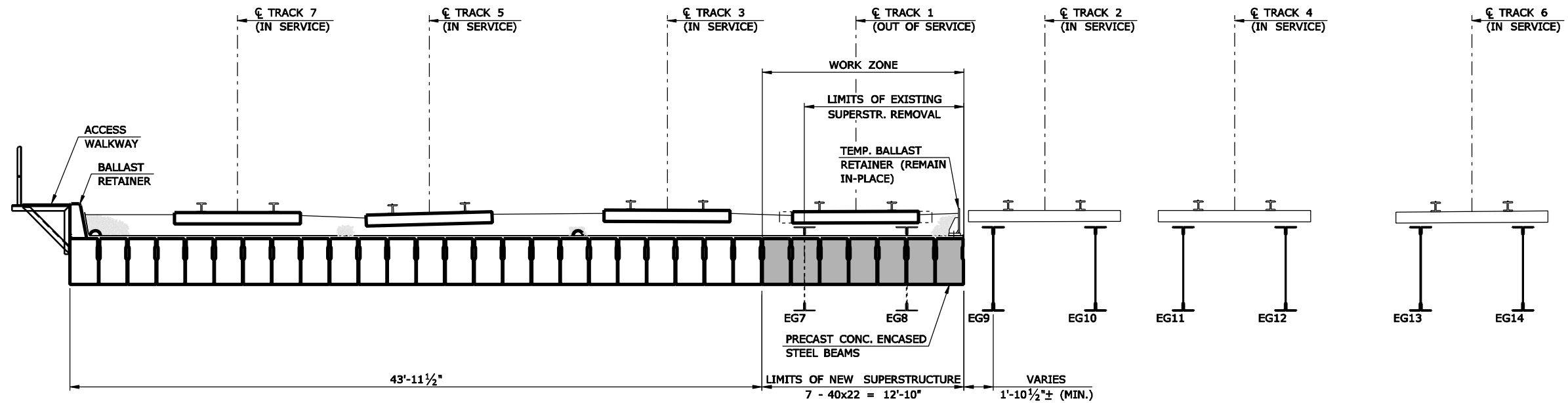

STAGE 4

STAGE CONSTRUCTION - PRECAST MULTIPLE CONCRETE ENCASED STEEL GIRDERS

SCALE: 1/8" = 1'-0"

SOUTH STAMFORD ACCESSIBILITY
& MNRR BRIDGE REPLACEMENT
FEASIBILITY STUDY

CANAL STREET
CONSTRUCTION STAGING SECTION

URS

SCALE AS NOTED

FIGURE 4.3B

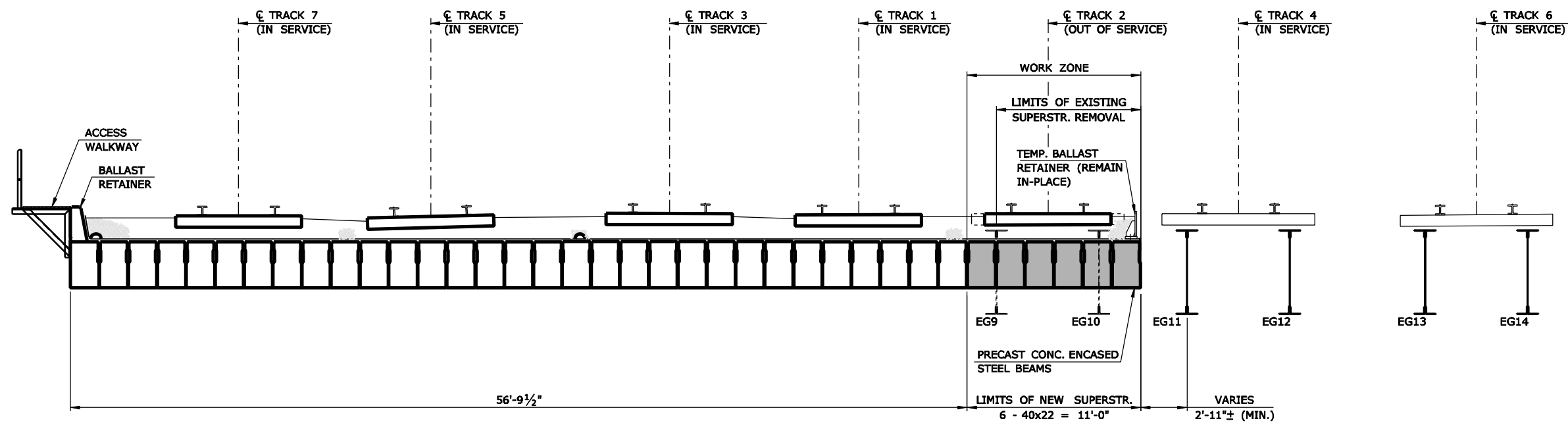

STAGE 5

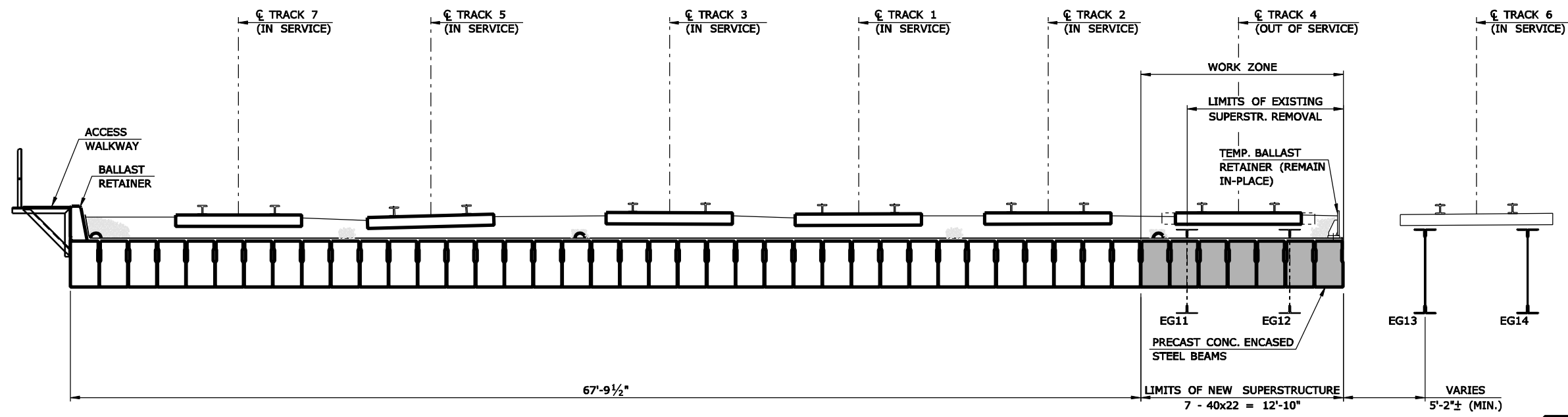

STAGE 6

STAGE CONSTRUCTION - PRECAST MULTIPLE CONCRETE ENCASED STEEL GIRDERS

SCALE: 1/8" = 1'-0"

**SOUTH STAMFORD ACCESSIBILITY
& MNRR BRIDGE REPLACEMENT
FEASIBILITY STUDY**

**CANAL STREET
CONSTRUCTION STAGING SECTION**

URS

SCALE AS NOTED

FIGURE 4.3C

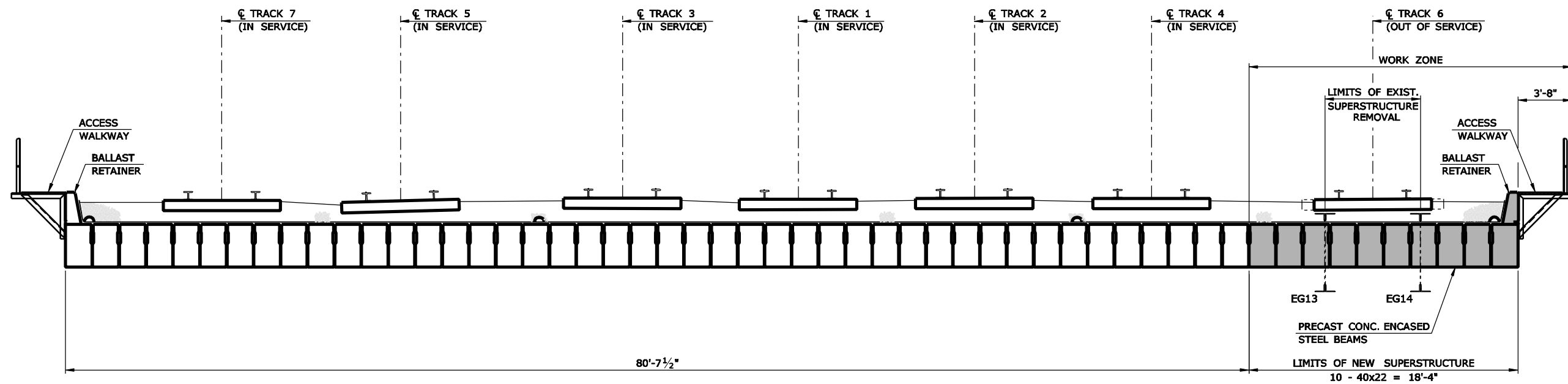

STAGE 7

STAGE CONSTRUCTION - PRECAST MULTIPLE CONCRETE ENCASED STEEL GIRDERS

SCALE: 1/8" = 1'-0"

SOUTH STAMFORD ACCESSIBILITY
& MNRR BRIDGE REPLACEMENT
FEASIBILITY STUDY

CANAL STREET
CONSTRUCTION STAGING SECTION

URS

SCALE AS NOTED

FIGURE 4.3D

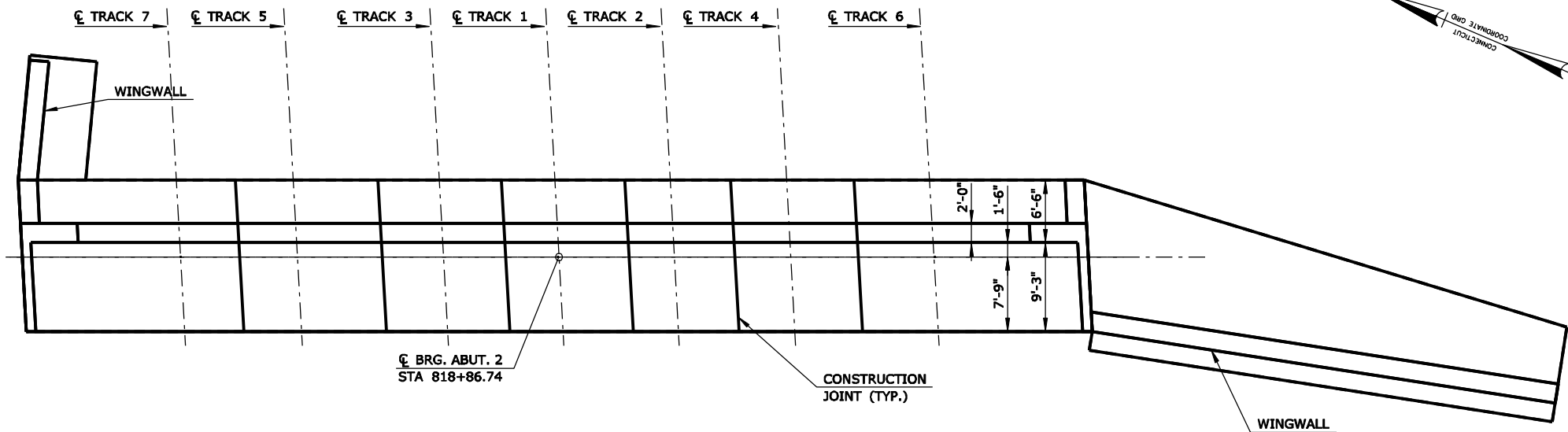

ABUTMENT 2 PLAN
SCALE: 1/16" = 1'-0"

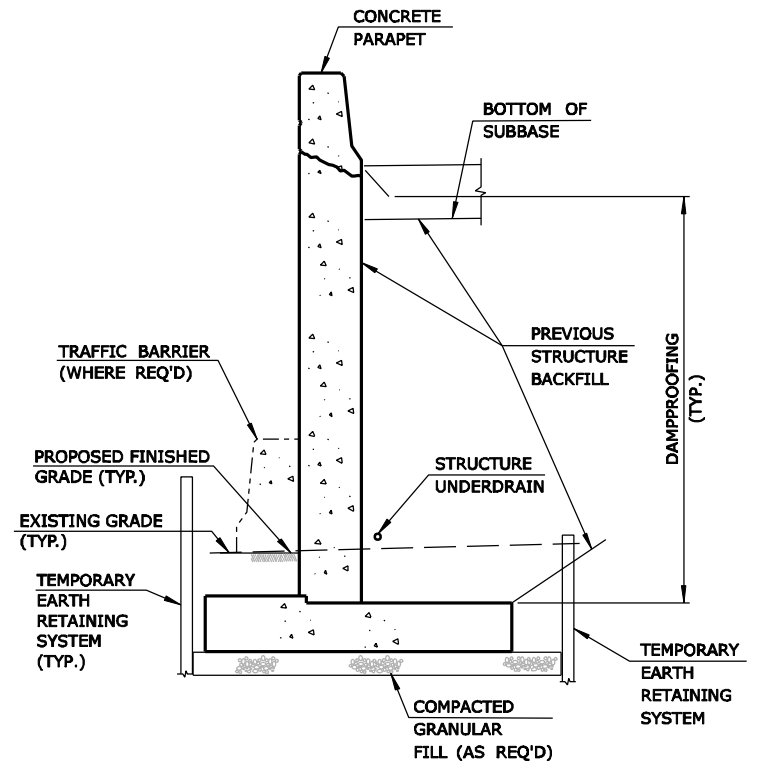

WINGWALL SECTION
SCALE: 1/8" = 1'-0"

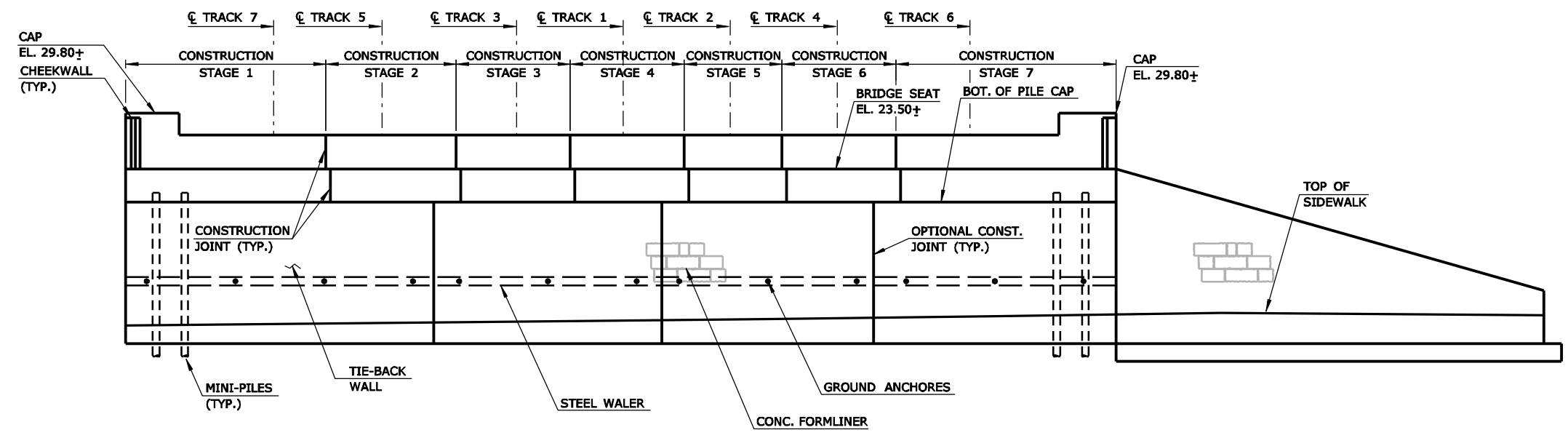

ABUTMENT 2 ELEVATION
SCALE: 1/16" = 1'-0"

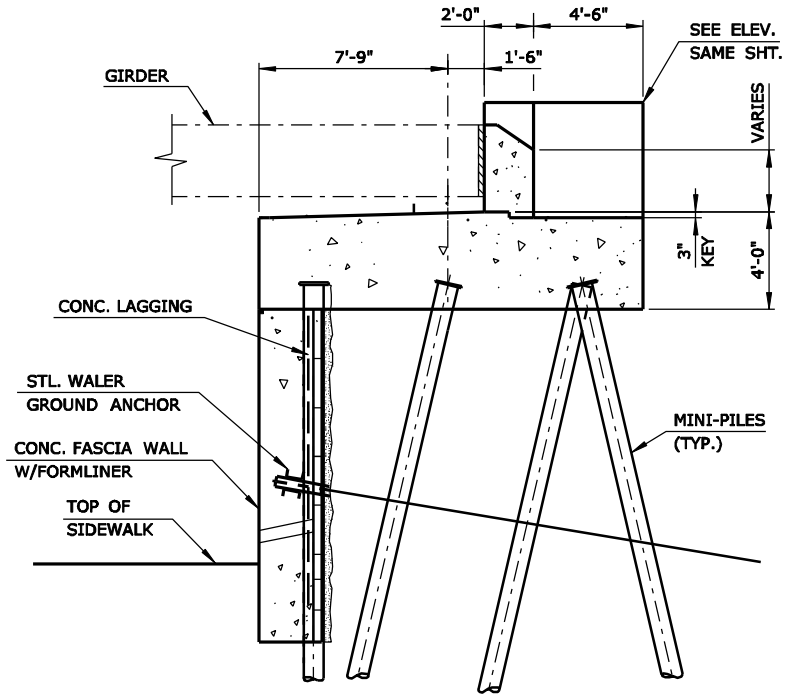

ABUTMENT SECTION
SCALE: 1/8" = 1'-0"

SOUTH STAMFORD ACCESSIBILITY & MNRR BRIDGE REPLACEMENT FEASIBILITY STUDY		
CANAL STREET ABUTMENT 2		
URS	SCALE AS NOTED	FIGURE 4.4

p:\ctdot_projects\135-301\struct\canal\st\msta_sheet_files\canal_st_abut_elev_section.dgn 3/3/2011

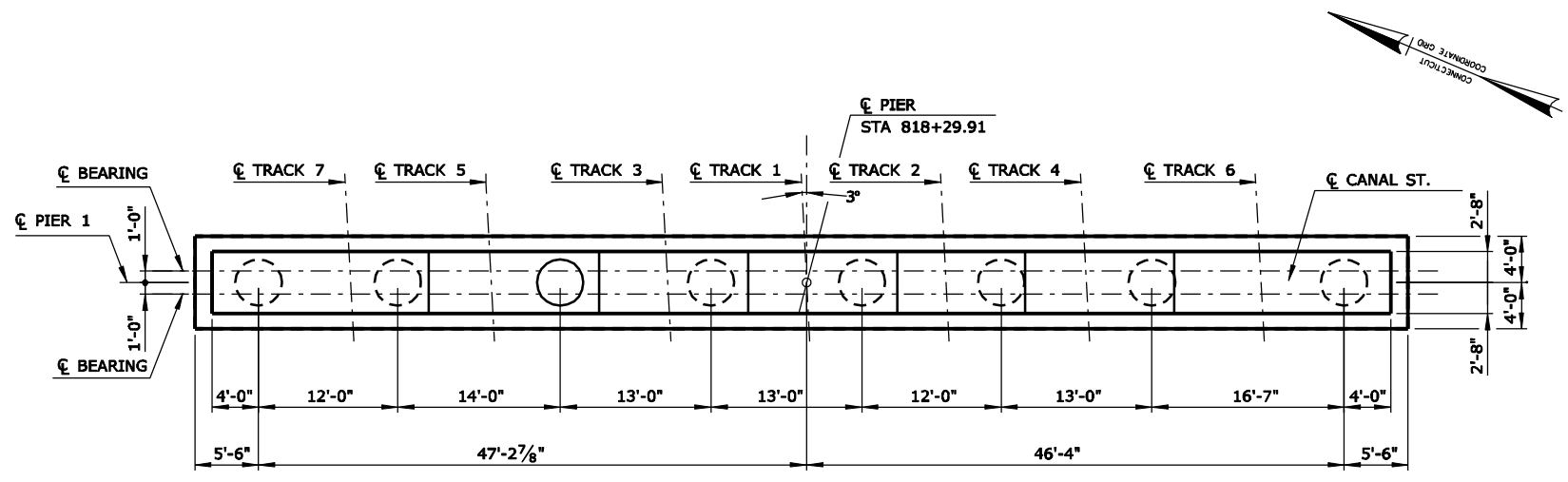

PIER PLAN
SCALE: 1/16" = 1'-0"

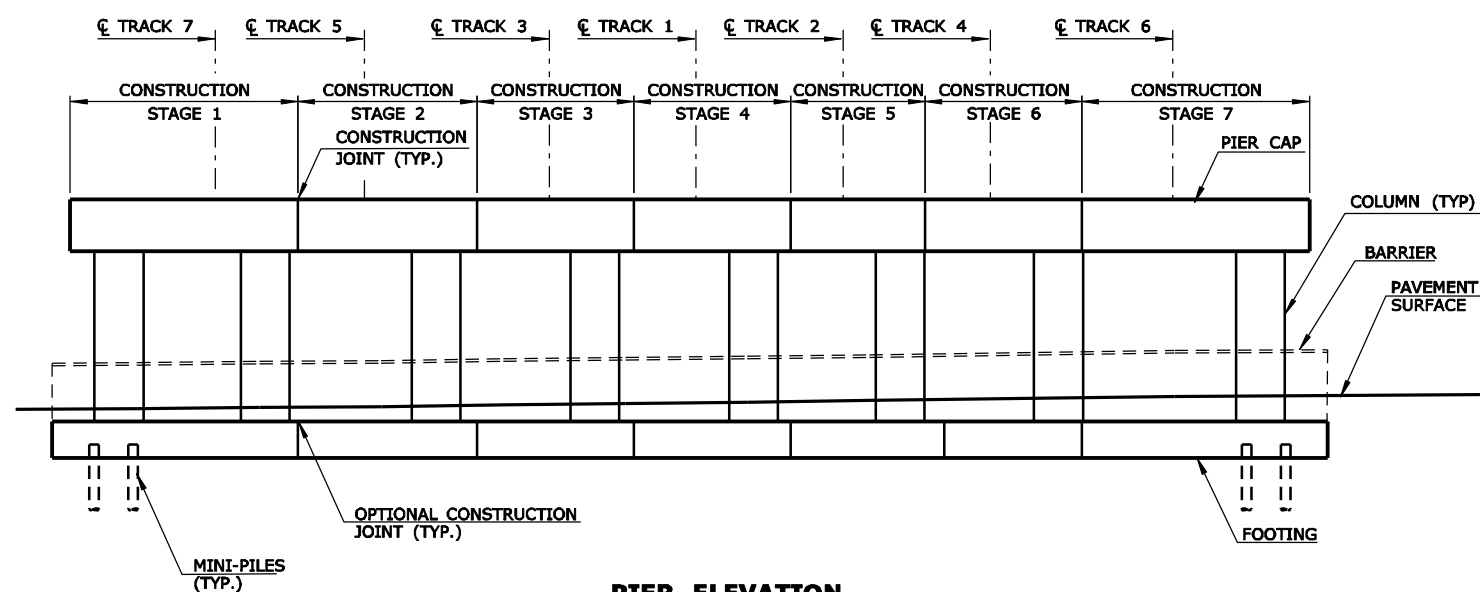

PIER ELEVATION
SCALE: 1/16" = 1'-0"

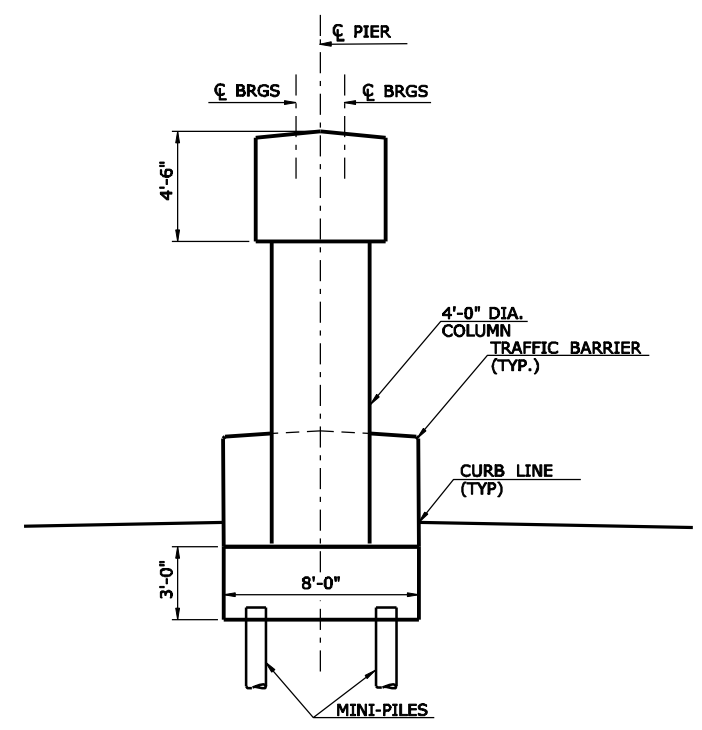

SECTION
SCALE: 1/8" = 1'-0"

SOUTH STAMFORD ACCESSIBILITY & MNRB BRIDGE REPLACEMENT FEASIBILITY STUDY		
CANAL STREET PIER		
URS	SCALE AS NOTED	FIGURE 4.5

p:\ctdot_projects\135-301\struct_bridge\canal_st\msta_sheet_files\Canal St - Pier Elev. Section.dgn 3/3/2011

MAINTENANCE AND PROTECTION OF TRAFFIC

- MAINTAIN ONE LANE OF TRAFFIC IN EACH DIRECTION DURING CONSTRUCTION OF ABUTMENTS AND PIERS.
- MAINTAIN PEDESTRIAN ACCESS ON EXISTING SIDEWALK ALONG EAST ABUTMENT AND CLOSE SIDEWALK ALONG WEST ABUTMENT TO PEDESTRIAN TRAFFIC.
- CLOSE ROADWAY TO TRAFFIC TO INSTALL GIRDERS DURING WEEKEND PERIODS.

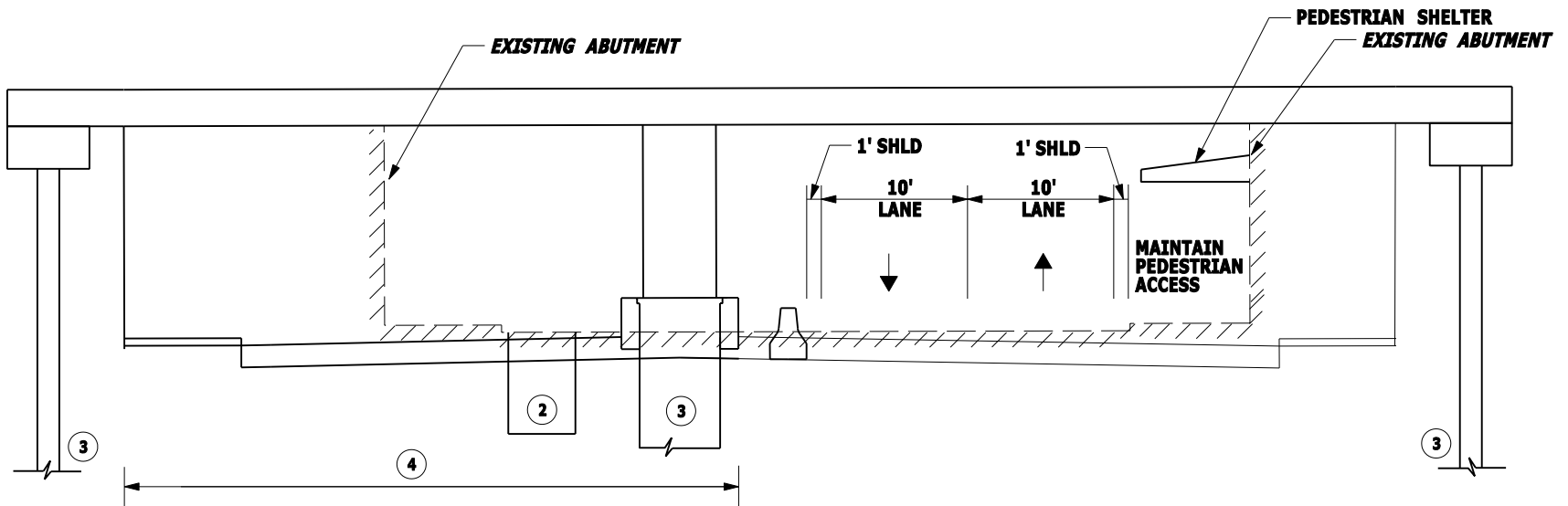

CANAL STREET LOOKING NORTHBOUND

CONSTRUCTION STAGING

1. INSTALL PEDESTRIAN SHELTER.
2. RELOCATE UTILITIES AS REQUIRED.
3. CONSTRUCT ABUTMENTS AND PIERS.
4. DEMOLISH EXISTING WEST ABUTMENT AND RECONSTRUCT ROADWAY AND SIDEWALK BETWEEN WEST ABUTMENT AND PIER.

SOUTH STAMFORD ACCESSIBILITY
& MNRR BRIDGE REPLACEMENT
FEASIBILITY STUDY

CANAL STREET
ROADWAY MPT - STAGE 1

URS

SCALE: 1"=12'

FIGURE 6.1a

MAINTENANCE AND PROTECTION OF TRAFFIC

- MAINTAIN ONE LANE OF TRAFFIC IN EACH DIRECTION DURING CONSTRUCTION OF ROADWAY AND SIDEWALK.
- MAINTAIN PEDESTRIAN ACCESS ON RECONSTRUCTED SIDEWALK ALONG WEST ABUTMENT AND CLOSE SIDEWALK ALONG EAST ABUTMENT.

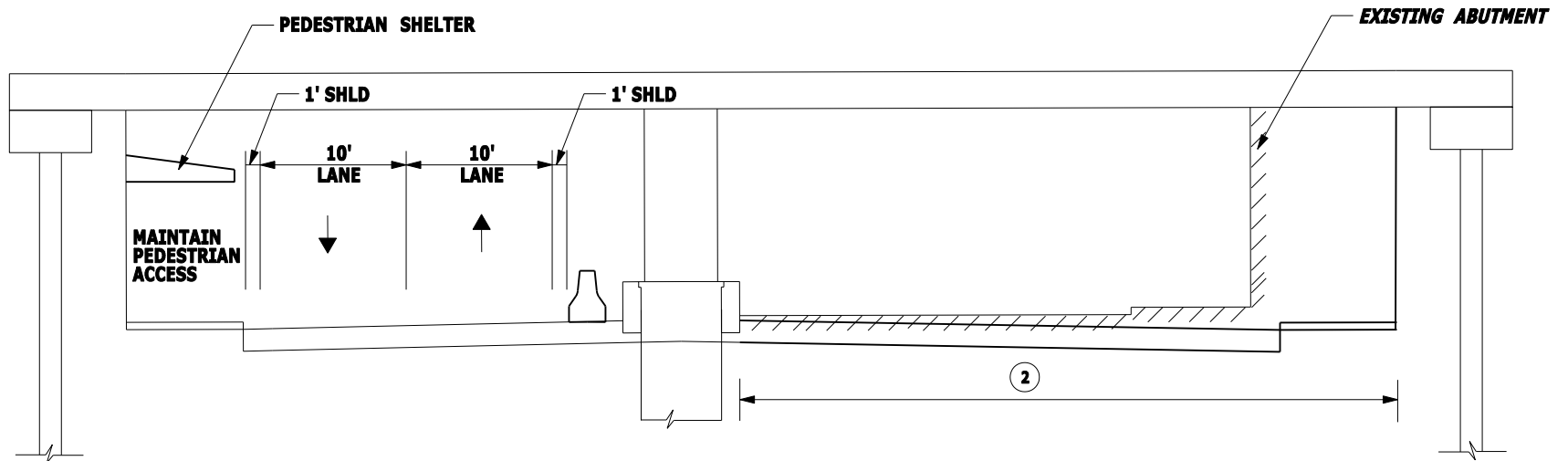

CANAL STREET LOOKING NORTHBOUND

CONSTRUCTION STAGING

1. INSTALL PEDESTRIAN SHELTER.
2. DEMOLISH EXISTING EAST ABUTMENT AND RECONSTRUCT ROADWAY AND SIDEWALK BETWEEN EAST ABUTMENT AND PIER.

SOUTH STAMFORD ACCESSIBILITY
& MNRR BRIDGE REPLACEMENT
FEASIBILITY STUDY

CANAL STREET
ROADWAY MPT - STAGE 2

URS

SCALE: 1"=12'

FIGURE 6.1b

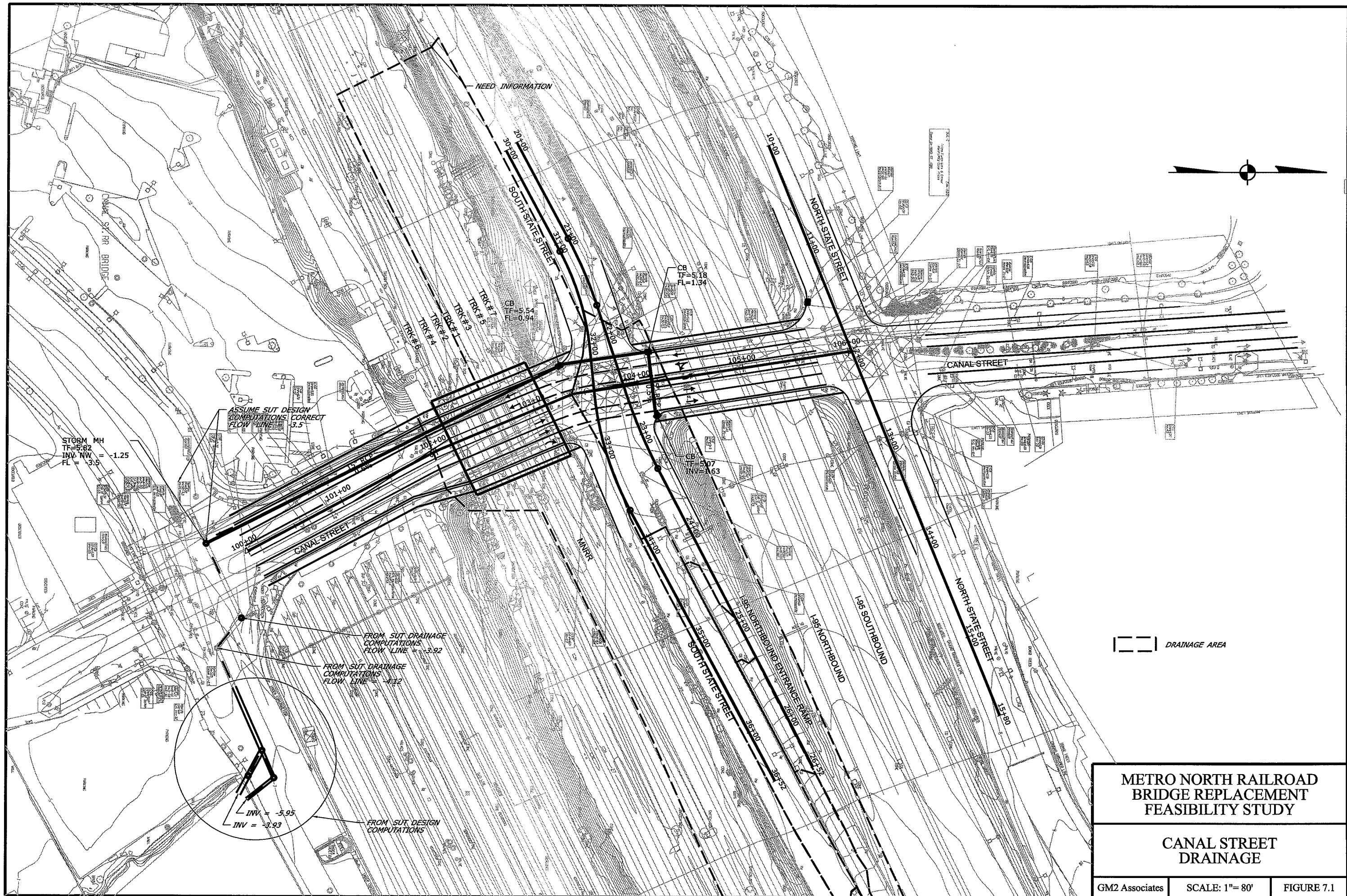

METRO NORTH RAILROAD
BRIDGE REPLACEMENT
FEASIBILITY STUDY

CANAL STREET
DRAINAGE

GM2 Associates

SCALE: 1"= 80'

FIGURE 7.1

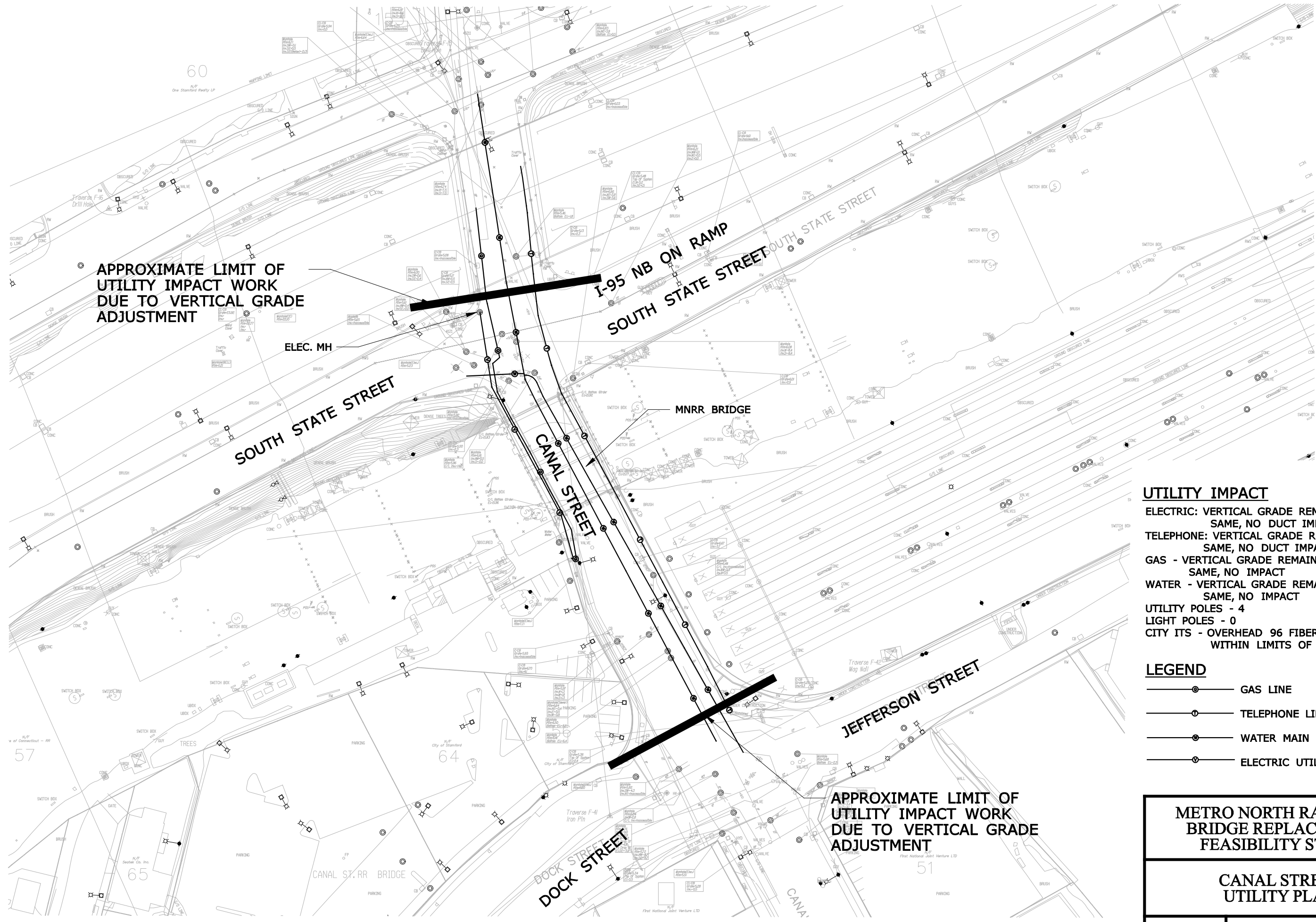

APPROXIMATE LIMIT OF UTILITY IMPACT WORK DUE TO VERTICAL GRADE ADJUSTMENT

APPROXIMATE LIMIT OF UTILITY IMPACT WORK DUE TO VERTICAL GRADE ADJUSTMENT

UTILITY IMPACT

- ELECTRIC: VERTICAL GRADE REMAINS THE SAME, NO DUCT IMPACT
- TELEPHONE: VERTICAL GRADE REMAINS THE SAME, NO DUCT IMPACT
- GAS - VERTICAL GRADE REMAINS THE SAME, NO IMPACT
- WATER - VERTICAL GRADE REMAINS THE SAME, NO IMPACT
- UTILITY POLES - 4
- LIGHT POLES - 0
- CITY ITS - OVERHEAD 96 FIBER WITHIN LIMITS OF WORK

LEGEND

- GAS LINE
- TELEPHONE LINE
- WATER MAIN
- ELECTRIC UTILITY LINE

METRO NORTH RAILROAD BRIDGE REPLACEMENT FEASIBILITY STUDY

CANAL STREET UTILITY PLAN

B-1

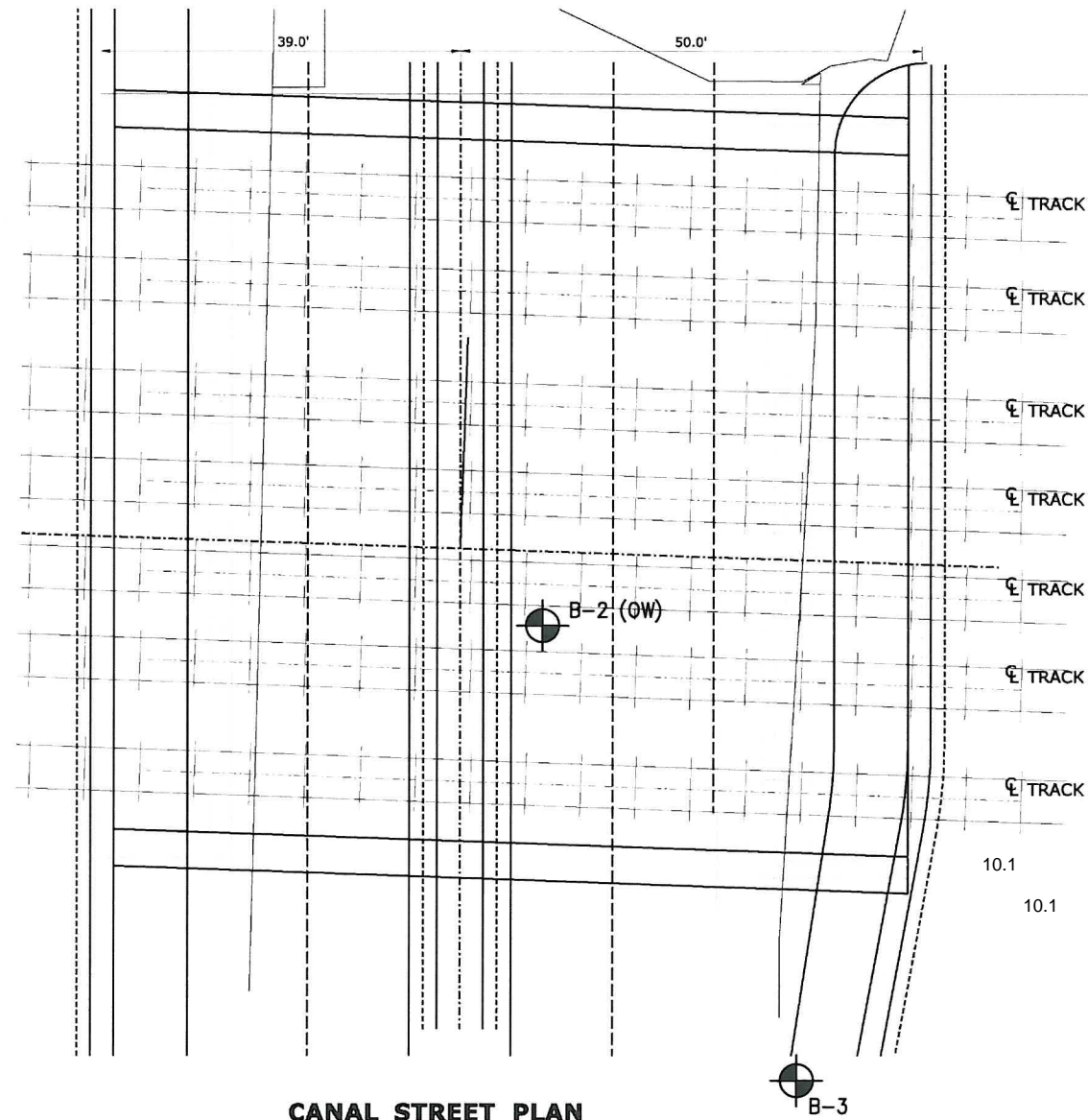

CANAL STREET PLAN

LEGEND

B-1 PROPOSED PILOT BORING

NOTES:

- 1) BASE MAP DEVELOPED FROM AN ELECTRONIC FILE PROVIDED BY URS ENTITLED 'METRO NORTH BRIDGE REPLACEMENT FEASIBILITY STUDY - CANAL STREET PLAN' DATED 1/11/2010. ORIGINAL SCALE 1/8" = 1'-0".
- 2) THE LOCATIONS OF THE BORINGS WERE DETERMINED BY TAPING AND VISUAL ESTIMATES FROM EXISTING SITE FEATURES.

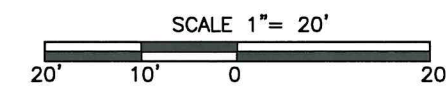

**METRO NORTH RAILROAD
BRIDGE REPLACEMENT
FEASIBILITY STUDY**

**CANAL STREET
PILOT BORING PROGRAM**

URS

SCALE: 1"=20'

FIGURE 9.1

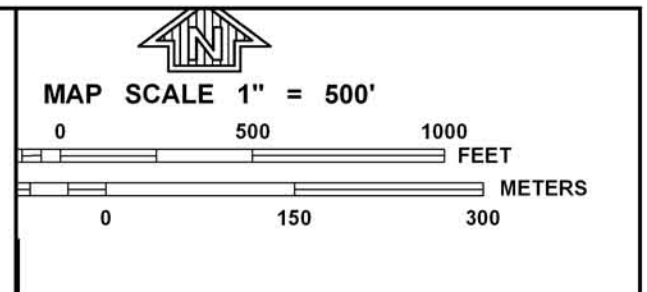
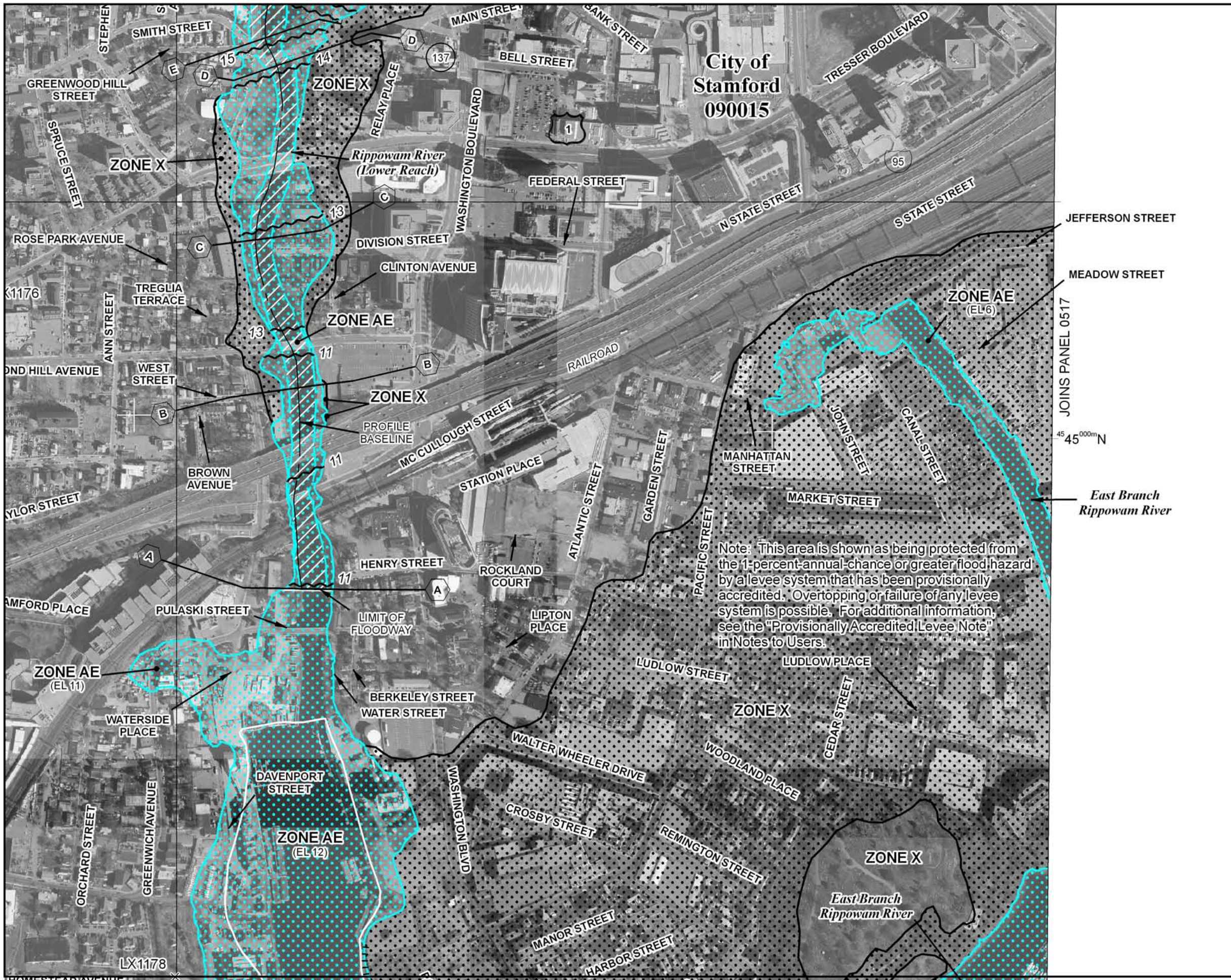

NFIP PANEL 0516F

FIRM
FLOOD INSURANCE RATE MAP

FAIRFIELD COUNTY, CONNECTICUT
(ALL JURISDICTIONS)

PANEL 516 OF 626
(SEE MAP INDEX FOR FIRM PANEL LAYOUT)

CONTAINS:

COMMUNITY	NUMBER	PANEL	SUFFIX
GREENWICH, TOWN OF	090008	0516	F
STAMFORD, CITY OF	090015	0516	F

Notice to User: The Map Number shown below should be used when placing map orders; the Community Number shown above should be used on insurance applications for the subject community.

MAP NUMBER
09001C0516F

EFFECTIVE DATE
JUNE 18, 2010

Federal Emergency Management Agency

**METRO NORTH RAILROAD
BRIDGE REPLACEMENT
FEASIBILITY STUDY**

**CANAL STREET
100-YEAR FEMA FLOODPLAIN**

URS SCALE: 1"=20' FIGURE 10.1

This is an official copy of a portion of the above referenced flood map. It was extracted using F-MIT On-Line. This map does not reflect changes or amendments which may have been made subsequent to the date on the title block. For the latest product information about National Flood Insurance Program flood maps check the FEMA Flood Map Store at www.msc.fema.gov