

### Location of Elements of a Welding Symbol

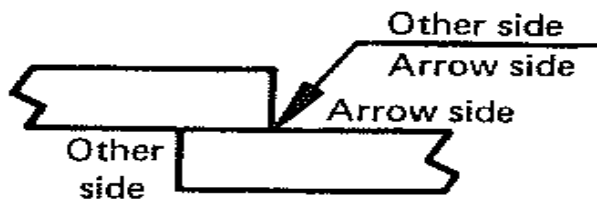

Weld all around	Field weld	Melt-thru	Backing or spacer material	Contour		
				Flush	Convex	Concave

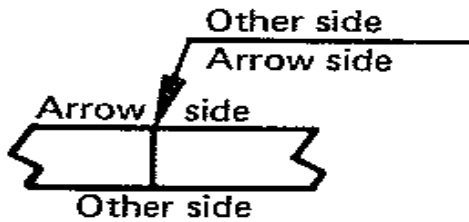
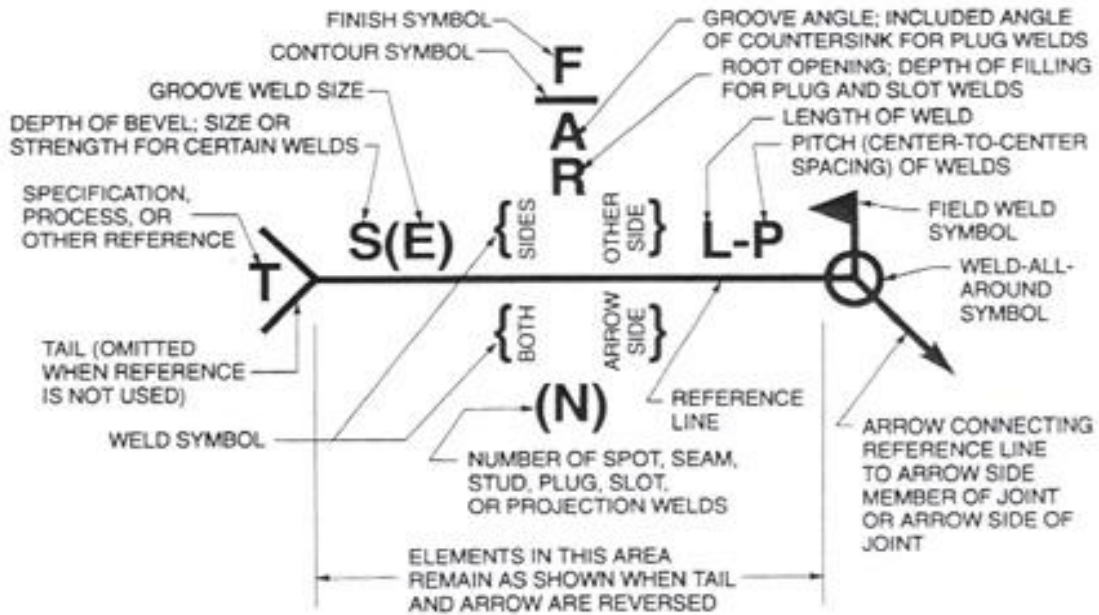
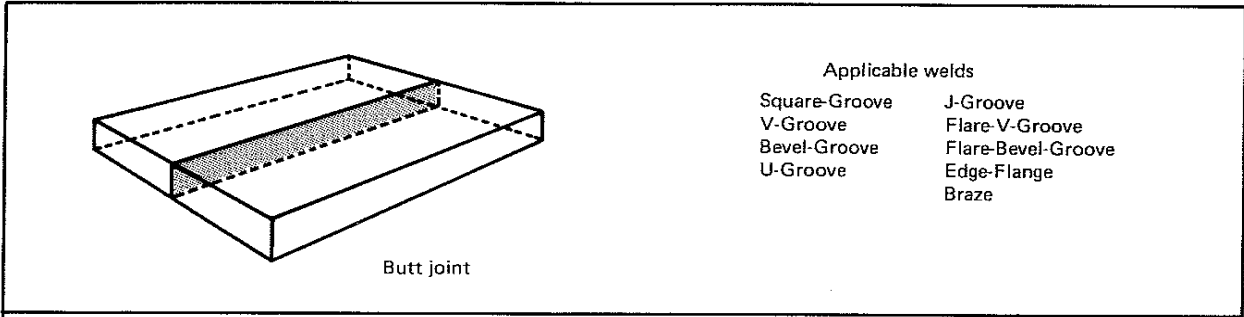

- Applicable welds
- |               |                    |
|---------------|--------------------|
| Square-Groove | J-Groove           |
| V-Groove      | Flare-V-Groove     |
| Bevel-Groove  | Flare-Bevel-Groove |
| U-Groove      | Edge-Flange        |
|               | Braze              |

Edge	Square	V	Bevel	U	J	Flare V	Flare bevel

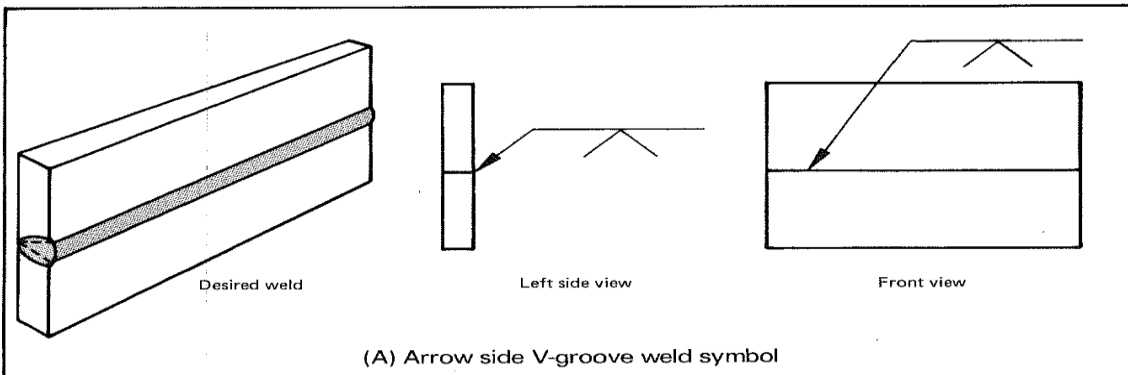

Examples

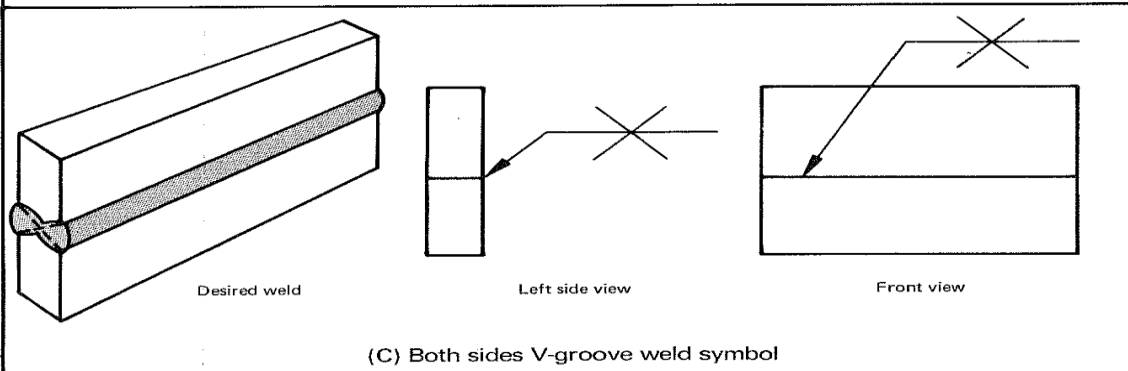
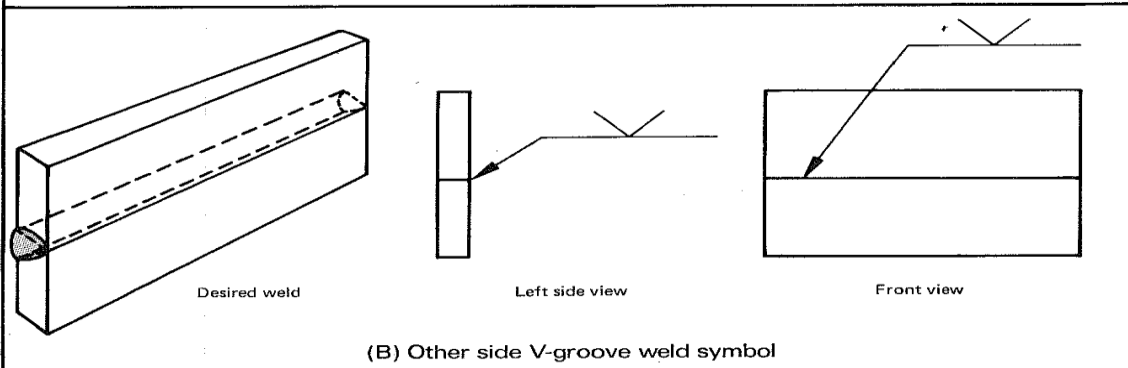

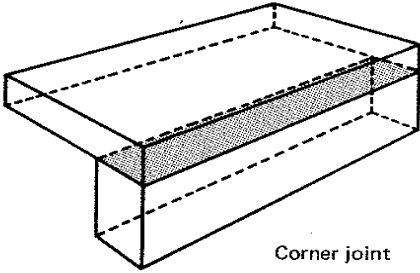

Corner joint

Applicable welds

- Fillet
- Square-Groove
- V-Groove
- Bevel-Groove
- U-Groove
- J-Groove
- Flare-V-Groove
- Flare-Bevel-Groove
- Edge-Flange
- Corner-Flange
- Spot
- Projection
- Seam
- Braze,

Square	V	Bevel	U	J	Flare V	Flare bevel
Fillet	Spot or projection	Seam	Flange			
			Edge	Corner		

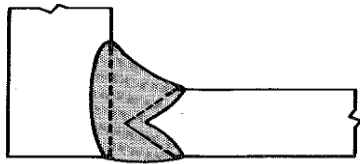

Desired welds

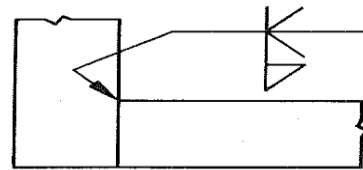

Symbol

(C) Fillet and double-bevel-groove weld symbols

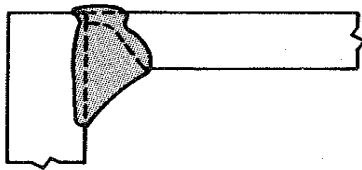

Desired welds

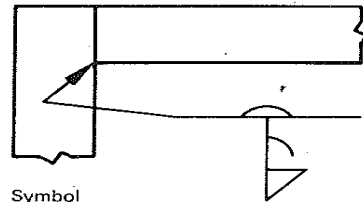

Symbol

(B) Back or backing, single-J-groove and fillet weld symbols

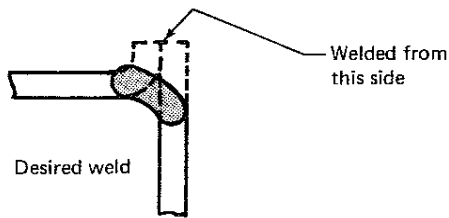

Desired weld

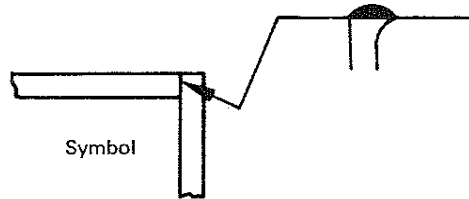

Symbol

Corner flange weld

(E)

Examples

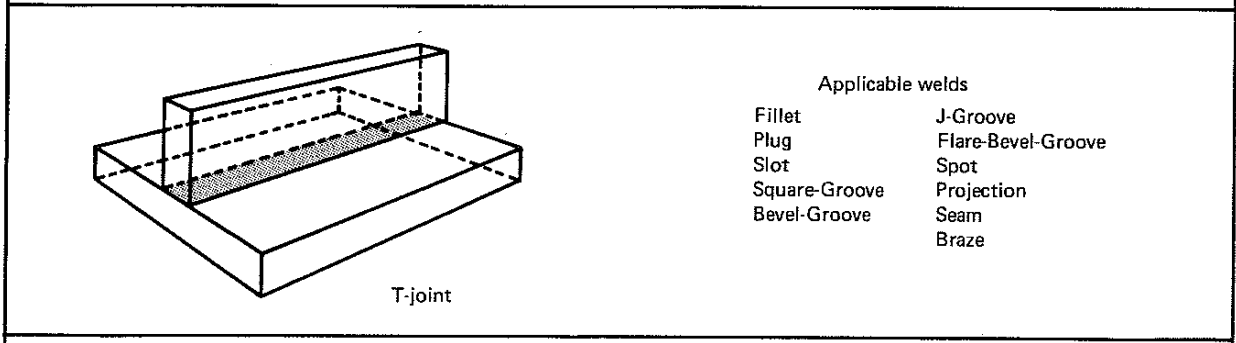

Square	Bevel	J	Flare bevel	Fillet	Plug or slot	Spot or projection	Seam

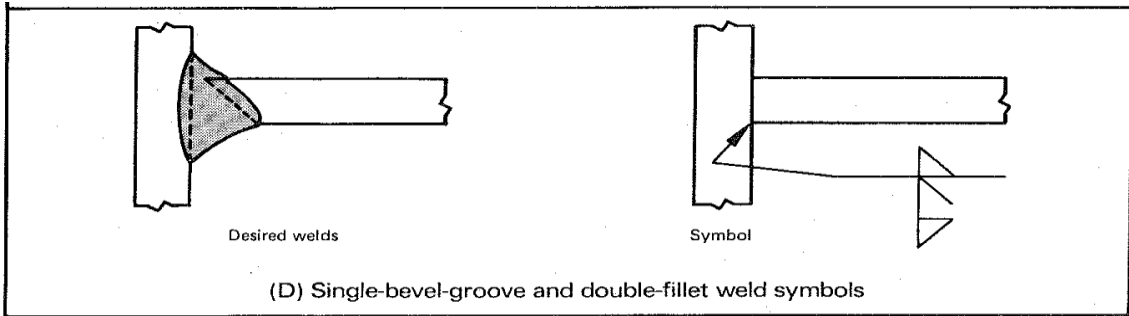

Examples

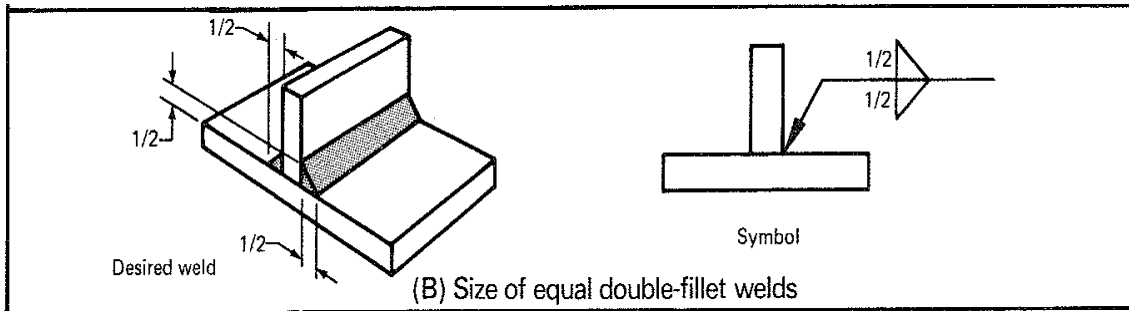
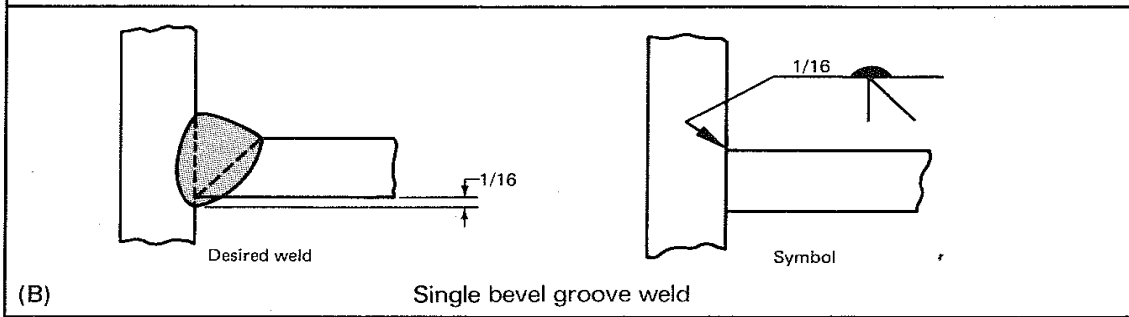

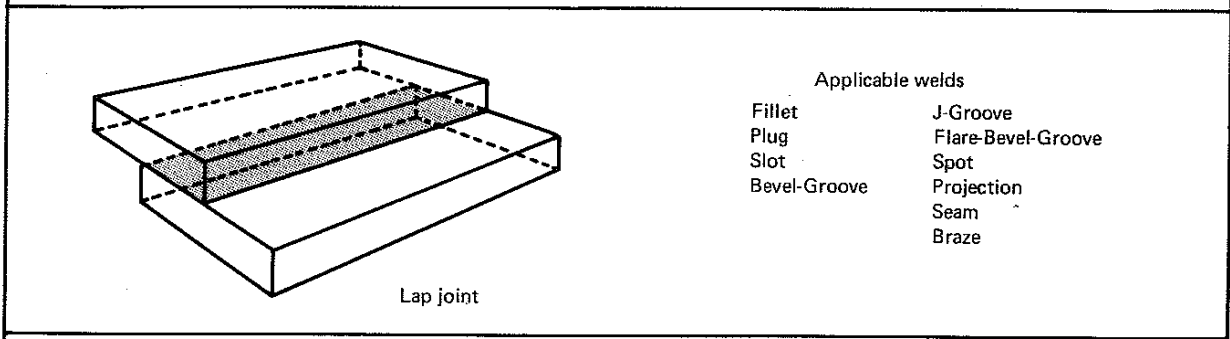

Bevel	J	Flare bevel	Fillet	Plug or slot	Spot or projection	Seam

Examples

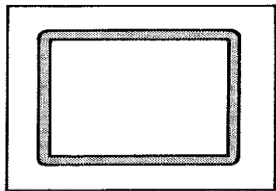

Desired weld

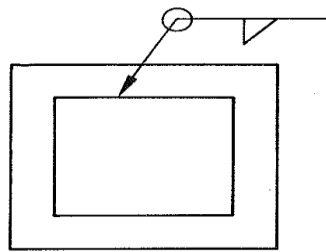

Symbol

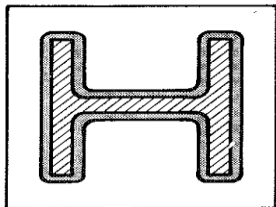

Desired weld

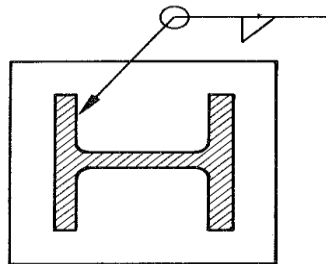

Symbol



Desired weld

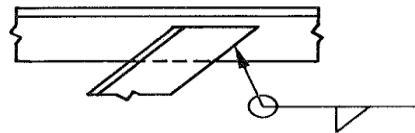

Symbol

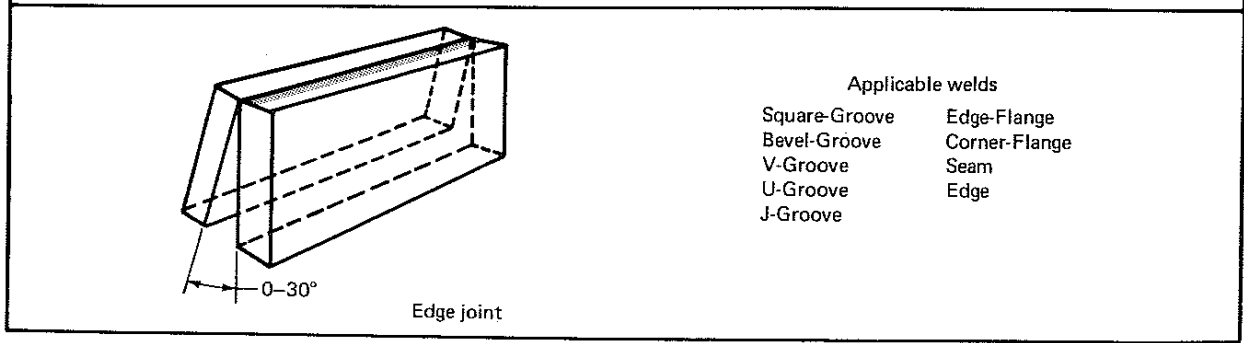

Square	V	Bevel	U	J	Seam	Flange	
						Edge	Corner

Examples

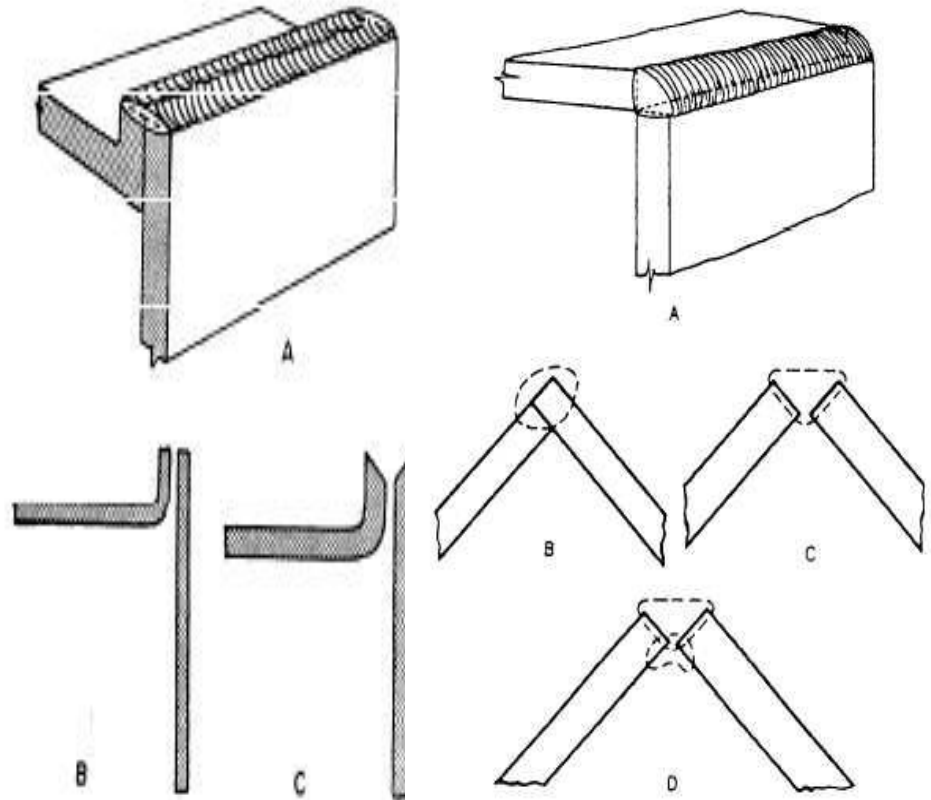

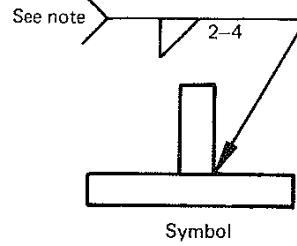
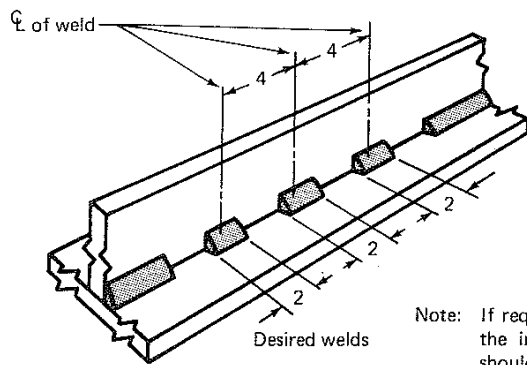

Symbol

Note: If required by actual length of the joint, the length of the increment of the welds at the end of the joint should be increased to terminate the weld at the end of the joint.

(A) Length and pitch of increments of intermittent welding

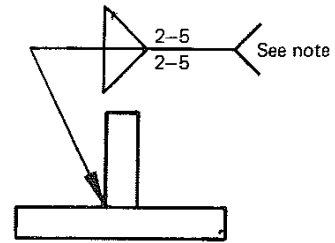
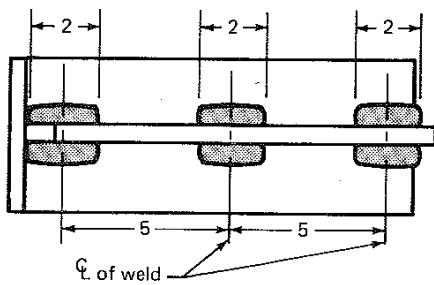

Symbol

Note: If required by actual length of the joint, the length of the increment of the welds at the end of the joint should be increased to terminate the weld at the end of the joint.

Desired welds

(B) Length and pitch of increments of chain intermittent welding

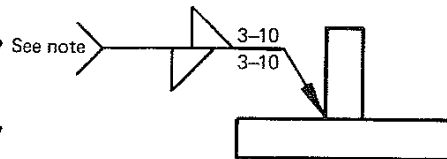
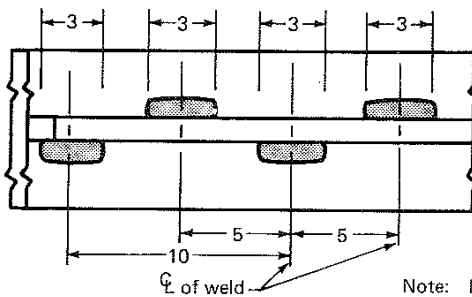

Symbol

Note: If required by actual length of the joint, the length of the increment of the welds at the end of the joint should be increased to terminate the weld at the end of the joint.

Desired welds

(C) Length and pitch of increments of staggered intermittent welding