

State of Connecticut
Department of Transportation

SUPPLEMENTAL SPECIFICATIONS
TO
STANDARD SPECIFICATIONS
FOR ROADS, BRIDGES, FACILITIES
AND INCIDENTAL CONSTRUCTION

FORM 818

2020

JULY 2022

TABLE OF CONTENTS
As of July 2022 Supplements

Division I
GENERAL REQUIREMENTS AND COVENANTS

Section	Rev Date	Notes
1.01 Definition of Terms & Permissible Abbreviations	July 2022	Errata
1.02 Proposal Requirements and Conditions		
1.03 Award and Execution of Contract.....		
1.04 Scope of Work		
1.05 Control of the Work.....	Jan 2022	& Errata
1.06 Control of Materials		
1.07 Legal Relations and Responsibilities.....	Jan 2022	Errata
1.08 Prosecution and Progress	Jan 2022	Errata
1.09 Measurement and Payment.....	Jan 2022	Errata
1.10 Environmental Compliance		
1.11 Claims		
1.20-1.00 General Clauses for Facilities Construction		
1.20-1.01 Definitions of Terms and Permissible Abbreviations. for Facilities Construction	July 2022	Errata
1.20-1.02 Proposal Requirements and Conditions for Facilities. Construction.....		
1.20-1.03 Award and Execution of Contract for Facilities Construction.....		
1.20-1.04 Scope of Work for Facilities Construction		
1.20-1.05 Control of the Work for Facilities Construction	Jan 2022	& Errata
1.20-1.06 Control of Materials for Facilities Construction.....		
1.20-1.07 Legal Relations and Responsibilities for Facilities..... Construction.....		
1.20-1.08 Prosecution and Progress for Facilities Construction.....		
1.20-1.09 Measurement and Payment for Facilities Construction.....	July 2020	Errata
1.20-1.10 Environmental Compliance for Facilities Construction.....		
1.20-1.11 Claims for Facilities Construction		
1.20-9.75 Mobilization and Project Closeout for Facilities Construction.....		
1.20-9.80 Construction Surveying for Facilities Construction	Jan 2022	

**Division II
CONSTRUCTION DETAILS**

EARTHWORK

Section	Rev. Date	Notes
2.01 Clearing and Grubbing.....		
2.02 Roadway Excavation, Formation of Embankment and Disposal of Surplus Material.....	Jan 2022	Errata
2.03 Structure Excavation	Jan 2022	Errata
2.04 Cofferdam and Dewatering, Cofferdam Material Left in Place.....		
2.06 Ditch Excavation.....	July 2020	Errata
2.07 Borrow	Jan 2022	Errata
2.08 Free-Draining Material		
2.09 Subgrade		
2.11 Anti-Tracking Pad.....	Jan 2022	
2.12 Subbase		
2.13 Granular Fill.....		
2.14 Compacted Granular Fill.....		
2.16 Pervious Structure Backfill		
2.19 Sedimentation Control System		
2.86 Drainage Trench Excavation, Rock in Drainage Trench Excavation.....	July 2021	
3.04 Processed Aggregate Base		
3.05 Processed Aggregate		

SURFACE COURSES OR PAVEMENTS

4.01 Concrete for Pavement	Jan 2022	Deleted
4.06 Bituminous Concrete	Jan 2021	
4.07 Rumble Strips, Removal of Rumble Strips.....	Jan 2021	
4.09 Milling, Removal of Wearing Surface	July 2020 &	Errata
4.15 Pressure Relief Joint		

STRUCTURES

5.03 Removal of Superstructure		
5.04 Railroad Protection		
5.06 Retaining Walls, Endwalls and Steps		
5.08 Shear Connectors		
5.09 Welded Studs		
5.13 Polyvinyl Chloride Plastic Pipe		
5.14 Prefabricated Concrete Structural Components.....	Jan 2022 &	Errata
5.21 Elastomeric Bearing Pads		

Section	Rev. Date	Notes
5.22 Elastomeric Compression Seal		
5.86 Catch Basins, Manholes and Drop Inlets	July 2021	Errata
6.01 Concrete for Structures	Jan 2022 &	Errata
6.02 Reinforcing Steel	July 2021	
6.03 Structural Steel	Jan 2022 &	Errata
6.05 Masonry Facing		
6.06 Cement Rubble Masonry	Jan 2022	Errata
6.07 Dry Rubble Masonry		
6.09 Repointed Masonry		
6.10 Drilling Holes and Bonding Anchors and Dowels	Jan 2022	
6.11 Shotcrete		
6.12 Concrete Cylinder Curing Box		
6.53 Clean Existing Drainage System		
6.86 Drainage Pipes, Drainage Pipe Ends	July 2021	

INCIDENTAL CONSTRUCTION

7.01 Drilled Shafts	Jan 2022	Errata
7.02 Piles		
7.03 Riprap		
7.04 Gabions		
7.05 Slope Paving		
7.06 Micropiles		
7.07 Membrane Waterproofing (Woven Glass Fabric) Vacant	July 2021	
7.08 Dampproofing		
7.13 Permanent Steel Sheet Piling		
7.14 Temporary Sheet Piling		
7.15 Sheet Piling Material Left in Place		
7.16 Temporary Earth Retaining System		
7.17 Earth Retaining System Left in Place		
7.28 Crushed Stone for Slope Protection		
7.32 Concrete Block Slope Protection		
7.51 Underdrain and Outlets		
7.55 Geotextile		
8.03 Paved Ditches , Paved Aprons and Paved Channels	July 2020	
8.11 Concrete Curbing		
8.13 Stone Curbing	July 2020	Errata
8.14 Reset Stone Curbing		
8.15 Bituminous Concrete Lip Curbing		
8.18 Protective Compound for Bridges	July 2020	Deleted
8.21 Precast Concrete Barrier Curb		
8.22 Temporary Traffic Barrier	July 2022	

Section	Rev. Date	Notes
9.04 Metal Bridge Rail.....		
9.05 Stone Wall Fence		
9.06 Wire Fence		
9.10 Metal Beam Rail.....	Jan 2022	& Errata
9.11 Metal Beam Rail Anchorages	Jan 2022	Errata
9.12 Remove and Reset Posts, Rail and Rail Anchorages		
9.13 Chain Link Fence		
9.14 Metal Handrail		
9.15 Tree Root Protection		
9.18 Three-Cable Guide Railing (I-Beam Posts) and Anchorages.....		
9.21 Concrete Sidewalks and Ramps	July 2022	& Errata
9.22 Bituminous Concrete Sidewalk, Bituminous Concrete Driveway		
9.23 Bituminous Concrete for Patching.....		
9.24 Concrete Driveway Ramp.....	July 2020	
9.30 Object Marker		
9.39 Sweeping for Dust Control		
9.42 Calcium Chloride for Dust Control.....		
9.43 Water for Dust Control		
9.44 Topsoil		
9.46 Liming.....		
9.49 Furnishing, Planting and Mulching Trees, Shrubs, Vines and Ground Cover Plants.....		
9.50 Turf Establishment, Erosion Control Matting		
9.51 Rock Excavation for Planting		
9.52 Selective Clearing and Thinning.....		
9.53 Sodding		
9.70 Trafficperson.....	July 2020	Errata
9.71 Maintenance and Protection of Traffic	July 2020	
9.74 Removal of Existing Masonry		
9.75 Mobilization and Project Closeout.....		
9.76 Barricade Warning Lights.....	July 2020	Errata
9.77 Traffic Cone	July 2020	
9.78 Traffic Drum	July 2020	
9.79 Construction Barricades.....	July 2020	
9.80 Construction Surveying	Jan 2022	Errata
9.81 42 Inch Traffic Cone.....	July 2020	
9.99 Disposal of Buildings.....		

TRAFFIC CONTROL

10.00 General Clauses for Highway Illumination and Traffic Signal Projects.....	Jan 2022	Errata
--	----------	--------

Section	Rev. Date	Notes
10.01 Trenching and Backfilling	Jan 2022	Errata
10.02 Light Standard and Traffic Control Foundations	July 2022	Errata
10.03 Light Standards		
10.04 Roadway Luminaire.....		
10.06 Underbridge Luminaire.....		
10.08 Electrical Conduit		
10.09 Cast Iron Junction Box.....		
10.10 Concrete Handhole.....	July 2022	Errata
10.11 4-Inch Drain Pipe		
10.12 Single Conductor		
10.14 Cable In Duct		
10.15 Grounding Conductor		
10.17 Service Entrance and Cabinet.....	Jan 2022	Errata
10.18 Navigation Light	Jan 2021	Deleted
11.01 Pole Anchor		
11.02 Pedestals.....		
11.03 Span Pole		
11.05 Traffic Signals.....		
11.06 Pedestrian Signal.....		
11.07 Pedestrian Pushbutton	Jan 2021	Errata
11.08 Controllers.....		
11.11 Loop Vehicle Detector and Sawcut		
11.12 Magnetic Vehicle Detector	Jan 2021	Deleted
11.13 Control Cable		
11.14 Messenger and Span Wire		
11.16 Illuminated Signs	July 2021	Errata
11.17 Alternate Flashing Signals for Warning Signs.....		
11.18 Removal and/or Relocation of Traffic Signal Equipment	Jan 2022	Errata
11.30 Arrow Board	July 2020	Errata
11.31 Remote Control Changeable Message Sign.....	July 2020	Errata
12.00 General Clauses for Highway Signing.....		
12.01 Overhead Sign Support.....		
12.02 Overhead Sign Support Foundation.....	Jan 2022	Errata
12.03 Side Mounted Sign Foundation		
12.04 Sign Panel Overlay		
12.05 Delineators.....	Jan 2022	Errata
12.06 Removal of Existing Signing, Removal of Existing Overhead Signing.....	Jan 2022	Errata
12.07 Sign Face - Extruded Aluminum		
12.08 Sign Face - Sheet Aluminum		
12.09 Painted Pavement Markings		
12.10 Epoxy Resin Pavement Markings.....	July 2021	Errata
12.11 Removal of Pavement Markings.....		

Section	Rev. Date	Notes
12.12 Temporary Plastic Pavement Marking Tape	Jan 2022	Errata
12.14 Preformed Black Line Mask Pavement Marking Tape	Jan 2022	Errata
12.20 Construction Signs	July 2020	Errata
13.00 Utilities.....		
14.00 Vacant		
15.00 Vacant		
16.00 Vacant		
18.02 Sand Barrels		
18.03 Impact Attenuation System, Temporary Impact Attenuation System.....	Jan 2022	Errata
18.06 Truck-Mounted or Trailer-Mounted Impact Attenuator	July 2021	Errata

**Division III
MATERIALS SECTION**

M.01 Aggregates		
M.02 Granular Fill, Subbase, Granular Base and Surfaces, Stone Base, Pervious Structure Backfill, Free-Draining Material, Crusher-Run Stone.....		
M.03 Portland and Hydraulic Cement Concrete	Jan 2022 &	Errata
M.04 Bituminous Concrete Materials.....	Jan 2022 &	Errata
M.05 Processed Aggregate Base and Pavement Surface Treatment.....	Jan 2021	
M.06 Metals.....	Jan 2022 &	Errata
M.07 Paint	July 2021 &	Errata
M.08 Drainage.....	July 2021	Errata
M.09 Sheet Piling and Piles.....	July 2021	Errata
M.10 Fence, Railing and Posts.....	July 2021	Errata
M.11 Masonry Facing, Cement and Dry Rubble, Masonry, Brick, Mortar		
M.12 Bearing Areas, Riprap, Slope Paving & Slope Protection, Waterproofing and Dampproofing, Stone and Granite Slope Curbing, Calcium Chloride for Dust Control, Wood....	Jan 2022	Errata
M.13 Roadside Development	July 2021	Errata
M.14 Prefabricated Concrete Members.....	Jan 2022	
M.15 Highway Illumination	Jan 2021 &	Errata
M.16 Traffic Control Signals	Jan 2021 &	Errata
M.17 Elastomeric Materials	July 2021	Errata
M.18 Signing	July 2021	Errata
List of Standard Pay Items	July 2022	Errata

Section or Article	Please make the following Corrections:	Rev. Date
Division I Part 1 - GENERAL REQUIREMENTS AND COVENANTS		
1.01.02	1. after the abbreviation for ADSC add “ AFBMA—Anti-Friction Bearing Manufacturer’s Association ” 2. after the abbreviation for AGC add “ AGMA—American Gear Manufacturer’s Association ” 3. after the abbreviation for AMRL add “ AMS—Aerospace Material Specification ” 4. after the abbreviation for AWWA add “ BGFMA—Bridge Grid Flooring Manufacturer’s Association ”	July20
1.01.02	1. after the abbreviation for AMCA add “ AMPP—The Association for Materials Protection and Performance [formerly NACE and SSPC] ” 2. after the abbreviation for EPA add “ ETL—Edison Testing Laboratories ” 3. after the abbreviation for IAS add “ IBC—International Building Code ” 4. revise the abbreviation for NACE to “ NACE—National Association of Corrosion Engineers see AMPP ” 5. after the abbreviation for NTMA add “ NTPEP —National Transportation Product Evaluation Program ” 6. after the abbreviation for RCSA add “ RCSC—Research Council on Structural Connections ” 7. revise the abbreviation for SSPC to “ SSPC—The Society for Protective Coatings (formerly The Steel Structures Painting Council) see AMPP ” but keep the NOTE	Jan21
1.01.02	1. after the abbreviation for ACI add “ ACMA—American Composites Manufacturers’ Association ” 2. After the abbreviation for NOAA add “ NPCA—National Precast Concrete Association ” 3. after the abbreviation for TIA/EIA add “ TMS—the Masonry Society ” 4. change the entry for USACOE to “ USACE—United States Army Corps of Engineers ”	July21
1.01.02	1. after the abbreviation for AASHTO add “ AASHTO re:source—A technical service program of AASHTO ” 2. revise the abbreviation for AMRL to “ AMRL—Materials Reference Library see AASHTO re:source ”	Jan22
1.01.02	1. After the abbreviation for DOD add “ DPDM - Digital Project Development Manual ” 2. revise the entry for ITE to” ITE—Institute of Transportation Engineers ” 3. after the abbreviation for OEO add “ OIS - Office of Information Systems ” 4. after the abbreviation for OSHA add “ OSTA—Office of State Traffic Administration ”	July22
1.01.03	1. after the abbreviation for pfmd. add “ PQR—procedure qualification record ” 2. after the abbreviation for surf. add “ TBD—to be determined ” 3. after the abbreviation for W add “ WPS—weld procedure specification ”	July20
1.01.03	after the abbreviation for CMS add “ CMU—concrete masonry unit ”	July21
1.05.12	in the first sentence of the paragraph that begins “Each such payroll shall include...” replace “... and, if applicable, ...” with “... or ...”	July20
1.07.11	change the first sentence as follows “Whenever, in the judgment of the Engineer...”	Jan22
1.08.05	change the second sentence as follows “The Engineer may demand...on the Project who is, in the judgment of the Engineer, guilty...”	Jan22
1.08.10	change the first sentence of the last paragraph to “...other methods or combinations thereof as in the Commissioner’s judgment shall be required...”	Jan22
1.09.02	1. change the first sentence to “These Value Engineering Change Proposal (VECP) provisions apply as encouragement to the Contractor to initiate, develop, and present to the Department for consideration cost-reduction proposals conceived by the Contractor, involving changes to the drawings, designs, specifications or other requirements of the Contract.”	July20

<u>Section or Article</u>	<u>Please make the following Corrections:</u>	<u>Rev. Date</u>
	2. <i>under the Subarticle “Payment for accepted VECPs,” delete “5. The cost savings from a VECP that is exclusively time reduction shall be calculated as the number of Contract days reduced multiplied by the amount of liquidated damages for 1 day under the Contract.”</i> <i>(VECPs based on time savings only will not be accepted)</i>	
1.09.04	<i>in the second to last paragraph of 1.09.04(a), change the end of the first sentence to “...when the nature of the pertinent Project work is such that, in the judgment of the Engineer, a superintendent was required for that work.”</i>	Jan22
Division I Part 2 - GENERAL REQUIREMENTS AND COVENANTS FOR FACILITIES CONSTRUCTION		
1.20-1.01.02	<ol style="list-style-type: none"> <i>after the abbreviation for ADSC add “AFBMA—Anti-Friction Bearing Manufacturer’s Association”</i> <i>after the abbreviation for AGC add “AGMA—American Gear Manufacturer’s Association”</i> <i>after the abbreviation for AMRL add “AMS—Aerospace Material Specification”</i> <i>after the abbreviation for AWWA add “BGFMA—Bridge Grid Flooring Manufacturer’s Association”</i> 	July20
1.20-1.01.02	<ol style="list-style-type: none"> <i>after the abbreviation for AMCA add “AMPP—The Association for Materials Protection and Performance [formerly NACE and SSPC]”</i> <i>after the abbreviation for EPA add “ETL—Edison Testing Laboratories”</i> <i>after the abbreviation for IAS add “IBC—International Building Code”</i> <i>revise the abbreviation for NACE to “NACE—National Association of Corrosion Engineers see AMPP”</i> <i>after the abbreviation for NTMA add “NTPEP—National Transportation Product Evaluation Program”</i> <i>after the abbreviation for RCSA add “RCSC—Research Council on Structural Connections”</i> <i>revise the abbreviation for SSPC to “SSPC—The Society for Protective Coatings (formerly The Steel Structures Painting Council) see AMPP” but keep the NOTE</i> 	Jan21
1.20-1.01.02	<ol style="list-style-type: none"> <i>after the abbreviation for ACI add “ACMA—American Composites Manufacturers’ Association”</i> <i>After the abbreviation for NOAA add “NPCA—National Precast Concrete Association”</i> <i>after the abbreviation for TIA/EIA add “TMS—the Masonry Society”</i> <i>change the entry for USACOE to “USACE—United States Army Corps of Engineers”</i> 	July21
1.20-1.01.02	<ol style="list-style-type: none"> <i>after the abbreviation for AASHTO add “AASHTO re:source—A technical service program of AASHTO”</i> <i>revise the abbreviation for AMRL to “AMRL—Materials Reference Library see AASHTO re:source”</i> 	Jan22
1.20-1.01.02	<ol style="list-style-type: none"> <i>After the abbreviation for DOD add “DPDM - Digital Project Development Manual”</i> <i>revise the entry for ITE to “ITE—Institute of Transportation Engineers”</i> <i>after the abbreviation for OEO add “OIS - Office of Information Systems”</i> <i>after the abbreviation for OSHA add “OSTA—Office of State Traffic Administration”</i> 	July22
1.20-1.01.03	<ol style="list-style-type: none"> <i>after the abbreviation for pfmd. add “PQR—procedure qualification record”</i> <i>after the abbreviation for surf. add “TBD—to be determined”</i> <i>after the abbreviation for W add “WPS—weld procedure specification”</i> 	July20
1.20-1.01.03	<i>after the abbreviation for CMS add “CMU—concrete masonry unit”</i>	July21
1.20-1.05.12	<i>in the first sentence of the paragraph that begins “Each such payroll shall include...” replace “... and, if applicable, ...” with “... or ...”</i>	July20

<u>Section or Article</u>	<u>Please make the following Corrections:</u>	<u>Rev. Date</u>
1.20-1.05.19	<i>change “1.20-1.05.19—Facilities Construction - Field Erector Prequalification” to “1.20-1.05.19—Facilities Construction - Field Erector Certification”</i>	Jan21
1.20-1.06.08	<i>change the last sentence in the second to last paragraph to “...unless in the Engineer’s judgment said failure is deemed to be an emergency...”</i>	Jan22
1.20-1.07.11	<i>change the first sentence to “Whenever, in the judgment of the Engineer, any portion of the Project...”</i>	Jan22
1.20-1.08.03	<i>in 1.20-1.08.03-4C, change the first sentence to “...in a manner that would, in the Engineer’s judgment,...”</i>	Jan22
1.20-1.08.05	<i>change the second sentence as follows “The Engineer may demand...on the Project who is, in the judgment of the Engineer, guilty...”</i>	Jan22
1.20-1.08.10	<i>change the first sentence of the last paragraph to “...other methods or combinations thereof as in the Commissioner’s judgment shall be required...”</i>	Jan22
1.20-1.09.02	<p>1. <i>change the first sentence to “These Value Engineering Change Proposal (VECP) provisions apply as encouragement to the Contractor to initiate, develop, and present to the Department for consideration cost-reduction proposals conceived by the Contractor, involving changes to the drawings, designs, specifications or other requirements of the Contract.”</i></p> <p>2. <i>under the Subarticle “Payment for accepted VECPs,” delete “5. The cost savings from a VECP that is exclusively time reduction shall be calculated as the number of Contract days reduced multiplied by the amount of liquidated damages for 1 day under the Contract.”</i></p> <p><i>(VECPs based on time savings only will not be accepted)</i></p>	July20
1.20-1.09.04	<i>in the second to last paragraph of 1.09.04(a), change the end of the first sentence to “...when the nature of the pertinent Project work is such that, in the judgment of the Engineer, a superintendent was required for that work.”</i>	Jan22
Division II CONSTRUCTION DETAILS		
2.02.03	<i>in the third paragraph of subarticle 5. Placement of Embankment Material replace “... slopes steeper than 1:3 ...” with “... slopes 1 vertical to 3 horizontal or steeper ...”</i>	July20
2.02.04	<i>in the fifteenth paragraph, revise the first sentence to “...strip or expose the rock to such an extent that in the Engineer’s judgment the necessary...”</i>	Jan22
2.03.04	<i>in the first paragraph, revise the second sentence to “...to such an extent that in the Engineer’s judgment the necessary measurements...”</i>	Jan22
2.06.01	<i>change the first sentence of the only paragraph as follows “...necessary for the construction of drainage ditches and paved leak-offs...”</i>	July20
2.06.04	<i>change subarticle 2. Paved Leak-offs and Paved Ditches to “2. Paved Leak-offs”</i>	July20
2.07.03	<i>revise the last sentence of the first paragraph to “This permission may be revoked by the Engineer at any time if in their judgment satisfactory progress...”</i>	Jan22
2.07.04	<i>revise the first sentence of 2.07.04(a) to “If, in the judgment of the Engineer...”</i>	Jan22
4.09.03	<i>revise the last sentence in 4.09.03-B to “Any deficiencies that could, in the Engineer’s judgment, cause failure of...”</i>	Jan22
5.14.04	<i>revise subarticle 5 to “5. Precast Substructure Element (Type): Precast Substructure Elements (Type) will be measured for payment by the number of cubic yards installed at the location indicated on the plans.”</i>	July22
5.14.05	<p>1. <i>revise subarticle 5 to “5. Precast Substructure Element (Type): This work will be paid for at the Contract unit price per cubic yard for “Precast Substructure Element (Type)” complete in place, including all materials, equipment and tools and labor incidental thereto.</i></p> <p>2. <i>revise the fifth line of the Pay Item table to “Precast Substructure Element (Type)”</i></p>	July22
6.03.03	<i>in the second paragraph of subarticle 6.03.03-4(e) Inspection, change the third sentence as follows “A Materials Certificate in accordance with 1.06.07 or 1.20-1.06.07 may be used...”</i>	July21
6.06.03	<i>revise the last sentence of subarticle 6.05.03-3 to “...mortar has attained a strength sufficient, in the judgment of the Engineer,...”</i>	Jan22

<u>Section or Article</u>	<u>Please make the following Corrections:</u>	<u>Rev. Date</u>
7.01.03	1. <i>in the third to last paragraph of subarticle 7.01.03-18, revise the last sentence to “If at any time, in the judgment of the Engineer,...”</i> 2. <i>revise the last sentence of subarticle 7.01.03-25 to “...satisfactorily accomplished by free fall, in the judgment of the Engineer,...”</i>	Jan22
8.13.04	<i>change the only sentence as follows “... will be measured for payment along the top arris line of the curb ...”</i>	July20
8.22.02	<i>change the first sentence as follows “The materials for this work shall meet the requirements of 8.21.02, except the reinforcing steel does not need to be galvanized.”</i>	Jan21
9.11.02	<i>in the second sentence, change “M.03.07” to “M.03.05”</i>	Jan22
9.22.02	<i>in 9.22.02-2, delete “, HMA S0.375 ”at the end of the sentence</i>	Jan22
9.70.03	<i>in the first sentence of paragraph 5, insert “the” before “MUTCD”</i>	July20
9.76.03	<i>change the last paragraph to “... in accordance with the ATSSA “Quality Guidelines for Temporary Traffic Control Devices and Features,” shall be ...”</i>	July20
9.80.03	<i>in 9.80.03-IV-12, revise the first sentence as follows. “The Contractor shall survey and stake other work such as guiderail, curb and gutter, seeding, regulated areas...”</i>	Jan22
10.00.10	<i>in the first sentence of the second paragraph under 10.00.10-2(b)-1, change “push button” to “pushbutton”</i>	Jan21
10.00.11	<i>Revise the eighth paragraph as follows “...seed and fertilize in accordance with 9.50, or as shown on the plans, all landscape grass areas disturbed...”</i>	Jan22
10.01.02	<i>revise the second paragraph to the following “Topsoil, fertilizer, seed and mulch shall be as specified in M.13, or as shown on the plans.”</i>	Jan22
10.02.02	1. <i>in the second line of the list, change “PCC03340” to “PCC04461”</i> 2. <i>revise the eighth line in the list to the following “M.13.04 for Seed Mixture, if necessary, or as shown on the plans”</i> 3. <i>in the second line of the list, change “PCC04461” to “PCC04460”</i>	Jan21 Jan22 July22
10.02.05	1. <i>in the first sentence, change “PCC03340” to “PCC04461”</i> 2. <i>in the first sentence, change “PCC04461” to “PCC04460”</i>	Jan21 July22
10.10.02	1. <i>in the third line of the list, change “PCC03360” to “PCC04461”</i> 2. <i>revise the eighth line in the list to the following “Seeding, M.13.04, if necessary, or as shown on the plans”</i> 3. <i>in the third line of the list, change “PCC04461” to “PCC04460”</i>	Jan21 Jan22 July22
10.17.05	<i>revise the end of the first paragraph as follows “...grading, topsoil, sodding or seeding, and all utility company charges.”</i>	Jan22
11.07	<i>change “push button” to “pushbutton” everywhere it appears</i>	Jan21
11.16.02	<i>in the only sentence, change “M.16.18” to “M.16.17”</i>	July21
11.18.03	<i>revise the fourth sentence of the last paragraph as follows “Topsoil to a minimum depth of 4 inches shall be applied and seeded as shown on the plans.”</i>	Jan22
11.30.02	<i>in the first paragraph, insert “the” before “MUTCD”</i>	July20
11.30.03	<i>change the second paragraph to “... in accordance with the ATSSA “Quality Guidelines for Temporary Traffic Control Devices and Features.”</i>	July20
11.31.02	<i>in the first paragraph, insert “the” before “MUTCD”</i>	July20
12.02.03	1. <i>revise the last sentence of the third paragraph to “...make use of the forms necessary, in the judgment of the Engineer...”</i> 2. <i>revise the first sentence of the sixth paragraph to “...has sufficiently set, in the judgment of the Engineer...”</i>	Jan22
12.05.03	<i>revise the second sentence of the second paragraph to “...or otherwise damaged to the extent that it is, in the judgment of the Engineer...”</i>	Jan22

<u>Section or Article</u>	<u>Please make the following Corrections:</u>	<u>Rev. Date</u>
12.06.03	<i>change the second sentence of the second to last paragraph as follows “Fertilizing and seeding shall be in accordance with pertinent provisions of 9.50 or as shown on the plans.”</i>	Jan22
12.10.03	<i>in the first paragraph of subarticle 12.10.03-3 Initial Performance, change the second sentence as follows “A Certified Test Report (CTR), in accordance with 1.06.07 or 1.20-1.06.07, must be submitted...”</i>	July21
12.12.05	<i>change the second to last paragraph to “... in accordance with the ATSSA “Quality Guidelines for Temporary Traffic Control Devices and Features,” shall be ...”</i>	July20
12.12.05	<i>revise the first sentence of the second paragraph to “Any lines which are no longer effective, in the judgment of the Engineer...”</i>	Jan22
12.14.05	<i>revise the first sentence of the second paragraph to “Any masking tape which is no longer effective, in the judgment of the Engineer...”</i>	Jan22
12.20.03	<i>change the second to last paragraph to “... in accordance with the ATSSA “Quality Guidelines for Temporary Traffic Control Devices and Features,” shall be ...”</i>	July20
18.03.05	<i>revise the last sentence to “Maintenance and protection of traffic will only be paid for when, in the judgment of the Engineer...”</i>	Jan22
18.06.02	<i>change the first sentence of Article 18.06.02 as follows “... a Materials Certificate in accordance with 1.06.07 or 1.20-1.06.07 for each...”</i>	July21
Division III MATERIALS SECTION		
M.04.01	<i>in the only paragraph of subarticle M.04.01-8 Joint Seal Material, change the second sentence as follows “... a Materials Certificate in accordance with 1.06.07 or 1.20-1.06.07 certifying that...”</i>	July21
M.06.01	<i>in the second paragraph of subarticle M.06.01-8 Reports and Certification, change the only sentence as follows “Materials Certificates shall be submitted in accordance with 1.06.07 or 1.20-1.06.07 for all...”</i>	July21
M.06.02	<ol style="list-style-type: none"> 1. <i>change the first sentence of Article M.06.02 as follows “... shall be submitted in accordance with 1.06.07 or 1.20-1.06.07.”</i> 2. <i>change the first sentence of subarticle M.06.02-2(b) Anchor Bolts as follows “... Certified Test Reports in accordance with 1.06.07 or 1.20-1.06.07.”</i> 3. <i>change the first sentence of subarticle M.06.02-3(f) Certified Test Reports and Materials Certificates as follows “... Certified Test Reports and Materials Certificates in accordance with 1.06.07 or 1.20-1.06.07...”</i> 4. <i>in subarticle M.06.02-4(d) Certified Test Reports and Materials Certificates change the first sentence as follows “... quality control test report in conformance with 1.06.07 or 1.20-1.06.07.” and change the second sentence as follows “... Materials Certificate in conformance with 1.06.07 or 1.20-1.06.07 ...”</i> 	July21
M.08.01	<i>change the only sentence in the first paragraph as follows “... metal coupling bands in accordance with 1.06.07 or 1.20-1.06.07.”</i>	July21
M.09.02	<i>change the last sentence of subarticle M.09.02-2 Treatment of Timber Piles as follows “... Materials Certificate, in accordance with 1.06.07 or 1.20-1.06.07, certifying...”</i>	July21
M.10.02	<i>change the last sentence of subarticle M.10.02-9 Plastic Blockouts as follows “... Materials Certificate for blockouts in conformance with 1.06.07 or 1.20-1.06.07.”</i>	July21
M.10.05	<i>in the second paragraph of subarticle M.10.05-2 Metal Posts and Rails, change the first sentence as follows “... Materials Certificate in accordance with 1.06.07 or 1.20-1.06.07 for all...”</i>	July21
M.12.06	<i>change the first sentence of subarticle M.12.06-1 as follows “... color variations as in the judgment of the Engineer...”</i>	Jan22
M.12.07	<i>change the first sentence of subarticle M.12.07-1 as follows “... color variations as, in the judgment of the Engineer...”</i>	Jan22
M.12.08	<i>change the first sentence of subarticle M.12.08-1 as follows “... color variations as in the judgment of the Engineer...”</i>	Jan22

<u>Section or Article</u>	<u>Please make the following Corrections:</u>	<u>Rev. Date</u>
M.12.13	<i>change the only sentence in the second paragraph as follows "... Materials Certificate in accordance with 1.06.07 or 1.20-1.06.07."</i>	July21
M.13.06	<i>change the last sentence in the first paragraph as follows "... Materials Certificate and Certified Test Report in accordance with Section 1.06.07 or 1.20-1.06.07."</i>	July21
M.13.07	<i>change subarticle "14. Miscellaneous" as follows "11. Miscellaneous"</i>	July21
M.15.15-5	<i>in the first sentence, change "PCC03340" to "PCC04461"</i>	Jan21
M.15.15-6	<i>in the first sentence, change "PCC03340" to "PCC04461"</i>	Jan21
M.16.08	<i>change "push button" to "pushbutton" everywhere it appears</i>	Jan21
M.17.01	<ol style="list-style-type: none"> <i>change the last sentence of subarticle M.17.01-3(c) as follows "... for each lot in accordance with the requirements of 1.06.07 or 1.20-1.06.07."</i> <i>change the first sentence of subarticle M.17.01-4(c) as follows "... for each batch in accordance with the requirements of 1.06.07 or 1.20-1.06.07."</i> 	July21
M.17.02	<ol style="list-style-type: none"> <i>change the last sentence of the second paragraph as follows "... for each lot in accordance with the requirements of 1.06.07 or 1.20-1.06.07."</i> <i>change the last sentence in the last paragraph as follows "... for each batch in accordance with the requirements of 1.06.07 or 1.20-1.06.07."</i> 	July21
M.18.10	<i>change the only sentence of subarticle M.18.10-3(M) Quality Assurance as follows "... Certified Test Report in accordance with 1.06.07 or 1.20-1.06.07 shall be submitted."</i>	July21
LIST OF STANDARD PAY ITEMS, ENGLISH/METRIC CONVERSION CHARTS, INDEX		
N/A	<ol style="list-style-type: none"> <i>delete "4.09, Micro-Milling of Bituminous Concrete (0" to 3"), s.y."</i> <i>change "4.09, Standard Milling of Bituminous Concrete (Greater Than 4" up to 8"), s.y." to "4.09, Coarse Milling of Bituminous Concrete (Greater Than 4" Up To 8"), s.y."</i> <i>change "4.09, Standard Milling of Bituminous Concrete (Greater Than 8"), s.y." to "4.09, Coarse Milling of Bituminous Concrete (Greater Than 8"), s.y."</i> <i>delete "8.03, Paved Ditch, s.y."</i> <i>delete "8.03, Paved Channel, s.y."</i> <i>delete "8.18, Protective Compound for Bridges, s.y."</i> 	July20
N/A	<ol style="list-style-type: none"> <i>add "4.07, Rumble Strips – Automated, l.f."</i> <i>add "4.07, Rumble Strips – Manual, l.f."</i> <i>add "4.07, Removal of Rumble Strips, l.f."</i> <i>delete "10.18, Navigation Light, ea."</i> <i>change "11.07, Pedestrian Push Button and Sign (Type), ea." to "11.07, Pedestrian Pushbutton and Sign (Type), ea."</i> <i>delete "11.12, Magnetic Vehicle Detector (Type), ea."</i> 	Jan21
N/A	<ol style="list-style-type: none"> <i>delete "7.07, Membrane Waterproofing (Woven Glass Fabric), s.y."</i> <i>change "9.21, Detectable Warning Strip, ea." to "9.21, Detectable Warning Surface, s.f."</i> 	July21
N/A	<ol style="list-style-type: none"> <i>delete "4.01, Concrete for Pavement, c.y."</i> <i>delete "4.01, Mat Reinforcement for Concrete Pavement, s.y"</i> <i>delete "4.01, Transverse Expansion Joints, l.f."</i> <i>delete "4.01, Transverse Contraction Joints, l.f."</i> <i>delete "4.01, Longitudinal Joint Support, ea."</i> <i>delete "4.01, (Type and Thickness) Expansion Joint Filler, l.f."</i> <i>replace "5.14, Prestressed Beams - Pretensioned Type (), l.f." with "5.14, Prestressed Beam (Type), l.f."</i> <i>add "5.14, Precast Approach Slab, s.y."</i> <i>add "5.14, Precast Concrete Walls, c.y."</i> <i>add "5.14, Precast Substructure Element, c.y."</i> <i>add "5.14, Precast Concrete Three-Sided Rigid Frame, l.f."</i> <i>add "6.10, Drilling Holes and Bonding Anchors, ea."</i> <i>add "6.10, Drilling Holes and Bonding Dowels, ea."</i> 	Jan22

<u>Section or Article</u>	<u>Please make the following Corrections:</u>	<u>Rev. Date</u>
N/A	1. <i>change</i> "5.14, Precast Substructure Element, c.y." to "5.14, Precast Substructure Element (Type), c.y." 2. <i>delete</i> "8.22, Temporary Precast Concrete Barrier Curb, l.f." 3. <i>delete</i> "8.22, Relocated Temporary Precast Concrete Barrier Curb, l.f." 4. <i>add</i> "8.22, Temporary Traffic Barrier, l.f." 5. <i>add</i> "8.22, Temporary Traffic Barrier (Pinned), l.f." 6. <i>add</i> "8.22, Temporary Traffic Barrier (Bolted), l.f." 7. <i>add</i> "8.22, Relocated Temporary Traffic Barrier, l.f." 8. <i>add</i> "8.22, Relocated Temporary Traffic Barrier (Pinned), l.f." 9. <i>add</i> "8.22, Temporary Traffic Barrier (Bolted), l.f."	July22

**SECTION 1.05
CONTROL OF THE WORK**

In the list of Articles, add the following:

1.05.19—Field Erector Certification

Replace the second paragraph of Article 1.05.08 with the following:

Baseline Bar Chart Construction Schedule: Within 20 calendar days after contract award the Contractor shall develop a comprehensive bar chart as a baseline schedule for the project. The bar chart schedule shall be submitted to the Engineer for review and comment and shall be based on the following guidelines:

Replace the General Activities Applicable to all projects list under 1.05.08-1 with the following:

Project Constraints

- Winter shutdowns
- Environmental permits/application time of year restrictions
- Milestones
- Third Party approvals
- Long lead time items (procurement and fabrication of major elements)
- Adjacent Projects or work by others

Award

Notice to Proceed

Signing (Construction, temporary, permanent by location)

Mobilization

Permits as required

Field Office

Utility Relocations

Submittals/shop drawings/working drawings/product data

Construction of Waste Stock pile area

Clearing and Grubbing

Removal of Invasives (if in Contract)

Earthwork (Borrow, earth ex, rock ex etc.)

Traffic control items (including illumination and signalization)

Pavement markings

Roadway Construction (Breakdown into components)

Drainage (Breakdown into components)

Culverts

Plantings (including seeding)

Semi-final inspection

Final Cleanup

Replace the fourth paragraph of Article 1.05.10 with the following:

If, at any time before the Department's acceptance of the Project, the Engineer requests the Contractor to remove or uncover any portion of the Project work for inspection by the Engineer, the Contractor shall do so. After such inspection is completed, the Contractor shall restore such portions of the work to the condition required by the Contract as construed by the Engineer. If the work or material exposed and inspected under this provision proves acceptable to the Engineer, the Department shall pay the Contractor for any removal, uncovering or restoration of its previous Contract work. The Department shall pay the Contractor for such removal, uncovering, and restoration of the prior work as extra work. If the work or material exposed and inspected proves, in the judgment of the Engineer, not to conform with Contract requirements, the Contractor shall be responsible for the costs of the removal, uncovering, correction and restoration of the work and material in accordance with the Contract or as the Engineer requires.

Replace Article 1.05.12 with the following:

1.05.12—Payrolls: For each week of the Project from the first week during which an employee of the Contractor does Project work to which prevailing wage requirements apply, until the last week on which such an employee does such work, the Contractor shall furnish to the Engineer certified copies of payrolls showing

- a. the names of the employees who worked on the Project and whose work is subject to prevailing wage requirements,
- b. the specific days and hours and numbers of hours that each such employee worked on the Project, and
- c. the amount of money paid to each such employee for Project work.

Each such payroll shall include the statement(s) of compliance with prevailing wage laws required by the State of Connecticut or by the Federal government. Said payrolls must contain all information required by CGS 31-53 (as it may be revised). For contracts subject to Federal prevailing wage requirements, each payroll shall also contain the information required by the Davis Bacon and Related Acts (DBR). All of the payroll requirements in this Article shall also apply to the work of any subcontractor or other party that performs work on the Project site, and the Contractor shall be responsible for ensuring that each such party meets said requirements. **No Social Security Numbers (in whole or in part) shall appear on any certified payrolls.**

Every Contractor or subcontractor performing Project work is required to post the relevant prevailing wage rates as determined by the State Labor Commissioner and, on federal aid projects, those determined by the United States Secretary of Labor. The wage rate determinations shall be posted in prominent and easily accessible places at the work site.

Replace the fifth paragraph of Article 1.05.17 with the following:

Prior to performing field welding on any permanent or temporary structure or component for Department projects, all field welders, field welding operators, and field tackers must possess a valid Welder **Qualification** issued by the Department's Division of Materials Testing (DMT), as outlined in the [Department's QA Program for Materials](#) and must be up to date in the Department's online Welder Database. If a welder has not been engaged in welding operations on a Department project or a project acceptable to the Department over the past 6 months, or does not possess an approved welding **qualification** dated within the past 12 months from a welding agency acceptable to the Engineer, the field welder shall be required to requalify through examination. The Engineer may require requalification of anyone whose quality of work is in question.

After 1.05.18, add the following:

1.05.19—Field Erector Certification: Contractors and subcontractors are required to possess AISC Certifications for the following work:

1. Field erection of steel bridge girders, beams or trusses – AISC Certified Steel Erector (CSE) Certification with Bridge Erection Endorsement
2. Field erection of fabricated steel sign supports (overhead and cantilever) – AISC Certified Steel Erector (CSE) Certification
3. Field erection of steel frames on Facilities Construction projects – AISC Certified Steel Erector (CSE) Certification for Steel-Framed Buildings

**SECTION 1.20-1.05
CONTROL OF THE WORK FOR
FACILITIES CONSTRUCTION**

In the list of Articles, revise the title 1.20-1.05.19 to the following:

1.20-1.05.19—Facilities Construction - Field Erector Certification

Replace the fourth paragraph of Article 1.20-1.05.03 with the following:

If, in the **judgment** of the Engineer, any material provided by the Contractor, any finished product in which the materials were used, or any work performed does not conform to the plans and specifications and has resulted in an unacceptable product, the Contractor shall, at its own expense, either cure or remove and replace the unaccepted work and material, as the Engineer directs.

Replace the third paragraph of Article 1.20-1.05.05 with the following:

Record Drawings: The Contractor shall maintain a complete set of Record Drawings by maintaining a clean, undamaged set of Contract drawings (original Contract plans as modified by Addenda and Construction Orders), Working Drawings (including any related calculations), Shop Drawings, and Coordination Drawings. The Contractor shall mark whichever drawings within the set that are most capable of **fully and accurately** showing **as-built** conditions. The Contractor shall include hyperlinks on the Contract plans to cross-reference to the related Working Drawings, Shop Drawings, Coordination Drawings, as well as RFIs and RFCs. The Contractor shall give particular attention to concealed elements that would be difficult to measure and record at a later date. The Contractor shall use separate colors to distinguish between variations in separate categories of the Project work.

Delete the sixth paragraph of Article 1.20-1.05.05:

Record Survey: The Contractor shall submit a Record Survey in accordance with other Contract requirements.

Replace the second paragraph of Article 1.20-1.05.08 with the following:

Baseline Bar Chart Construction Schedule: Within 20 calendar days after contract award the Contractor shall develop a comprehensive bar chart as a baseline schedule for the project. The bar chart schedule shall be submitted to the Engineer for **review and comment** and shall be based on the following guidelines:

Replace the General Activities Applicable to all projects list under 1.05.08-1 with the following:

Project Constraints

- Winter shutdowns
- Environmental permits/application time of year restrictions
- Milestones
- Third Party approvals
- Long lead time items (procurement and fabrication of major elements)
- Adjacent Projects or work by others

Award

- Notice to Proceed
- Signing (Construction, temporary, permanent by location)
- Mobilization
- Permits as required
- Field Office
- Utility Relocations

Submittals/shop drawings/working drawings/product data
 Construction of Waste Stock pile area
 Clearing and Grubbing
 Removal of Invasives (if in Contract)
 Earthwork (Borrow, earth ex, rock ex etc.)
 Traffic control items (including illumination and signalization)
 Pavement markings
 Roadway Construction (Breakdown into components)
 Drainage (Breakdown into components)
 Culverts
 Plantings (including seeding)
 Semi-final inspection
 Final Cleanup

Replace the fourth paragraph of Article 1.05.10 with the following:

If, at any time before the Department's acceptance of the Project, the Engineer requests the Contractor to remove or uncover any portion of the Project work for inspection by the Engineer, the Contractor shall do so. After such inspection is completed, the Contractor shall restore such portions of the work to the condition required by the Contract as construed by the Engineer. If the work or material exposed and inspected under this provision proves acceptable to the Engineer, the Department shall pay the Contractor for any removal, uncovering or restoration of its previous Contract work. The Department shall pay the Contractor for such removal, uncovering, and restoration of the prior work as extra work. If the work or material exposed and inspected proves, in the judgment of the Engineer, not to conform with Contract requirements, the Contractor shall be responsible for the costs of the removal, uncovering, correction and restoration of the work and material in accordance with the Contract or as the Engineer requires.

Replace Article 1.20-1.05.12 with the following:

1.20-1.05.12—Facilities Construction - Payrolls: For each week of the Project from the first week during which an employee of the Contractor does Project work to which prevailing wage requirements apply, until the last week on which such an employee does such work, the Contractor shall furnish to the Engineer certified copies of payrolls showing the names of the employees who worked on the Project and whose work is subject to prevailing wage requirements,

- (a) the specific days and hours and numbers of hours that each such employee worked on the Project, and
- (b) the amount of money paid to each such employee for Project work.

Each such payroll shall include the statement(s) of compliance with prevailing wage laws required by the State of Connecticut or by the Federal government. Said payrolls must contain all information required by CGS Section 31-53 (as it may be revised). For contracts subject to Federal prevailing wage requirements, each payroll shall also contain the information required by the Davis Bacon and Related Acts (DBR). All of the payroll requirements in this Article shall also apply to the work of any subcontractor or other party that performs work on the Project site, and the Contractor shall be responsible for ensuring that each such party meets said requirements. **No Social Security Numbers (in whole or in part) shall appear on any certified payrolls.**

Every Contractor or subcontractor performing Project work is required to post the relevant prevailing wage rates as determined by the State Labor Commissioner and, on federal aid projects, those determined by the United States Secretary of Labor. The wage rate determinations shall be posted in prominent and easily accessible places at the work site.

Replace the fifth paragraph of Article 1.05.17 with the following:

Prior to performing field welding on any permanent or temporary structure or component for Department projects, all field welders, field welding operators, and field tackers must possess a valid Welder Qualification issued by the Department's Division of Materials Testing (DMT), as outlined in the [Department's QA Program for Materials](#) and must be up to date in the Department's online Welder

Database. If a welder has not been engaged in welding operations on a Department project or a project acceptable to the Department over the past 6 months, or does not possess an approved welding qualification dated within the past 12 months from a welding agency acceptable to the Engineer, the field welder shall be required to requalify through examination. The Engineer may require requalification of anyone whose quality of work is in question.

Replace the title of Article 1.05.19 with the following:

1.20-1.05.19—Facilities Construction - Field Erector Certification:

After Section 1.20-9.75, add the following New Section 1.20-9.80:

**SECTION 1.20-9.80
CONSTRUCTION SURVEYING FOR
FACILITIES CONSTRUCTION**

1.20-9.80.01—Facilities Construction - Description

1.20-9.80.02—Facilities Construction - Materials

1.20-9.80.03—Facilities Construction - Construction Methods

1.20-9.80.04—Facilities Construction - Method of Measurement

1.20-9.80.05—Facilities Construction - Basis of Payment

1.20-9.80.01—Facilities Construction - Description: Work under this item shall consist of furnishing labor, equipment, tools and materials to perform surveying, staking, verification, recording of data and calculations as necessary to construct the Project, from existing layout to acceptance of the work according to the plans. Work under this item shall conform to Section 20-300b-1 to 20-300b-20 inclusive of the Department of Consumer Protection, Regulations of CT State Agencies and as supplemented herein.

1.20-9.80.02—Facilities Construction - Materials: Stakes used for control staking shall be a minimum of 1 inch × 1 inch wide and a minimum length of 36 inches. Stakes shall be legibly marked and shall be visible at all times. The stakes shall be durable enough to last for the duration of the Contract. In areas where traditional staking cannot be established, the Contractor may use other materials or methods to mark critical locations, as approved or directed by the Engineer.

1.20-9.80.03—Facilities Construction - Construction Methods:

I Submittals:

1. The Contractor shall provide technically qualified survey crews experienced in construction surveying. All Project surveying and staking shall be performed by or under the supervision of either a Connecticut Licensed Land Surveyor or a Level III Survey Technician certified by the National Society of Professional Surveyors.

The name, authority, relevant experience, and qualifications of the person with overall responsibility for construction surveying and staking shall be submitted to the Engineer ten (10) days prior to any physical work.

2. If using Automated Machine Guidance (AMG) methods, the following information shall also be submitted to the Engineer ten (10) days prior to any physical work:
 - A. A written technology statement that includes:
 - i. The manufacturer, model, and software version of the AMG equipment.
 - ii. Verification that the final 3D data which is provided in the Plans is compatible with the AMG equipment.
 - B. Personnel qualifications:
 - i. The name, authority, relevant experience, and qualifications of the person with overall responsibility for the AMG system.
 - ii. The name, authority, and relevant experience of personnel directly responsible for operating the AMG equipment.
 - C. A Quality Control Plan for mechanical calibration and maintenance of both surveying and AMG controlled construction equipment. Include the frequency and types of checks performed.

II Equipment Requirements:

1. The Contractor's survey instruments and supporting equipment shall be capable of achieving the specified tolerances in Table 1.20-9.80-1.
2. All instrumentation used on the Project shall have been serviced and calibrated within six (6) months prior to use on the Project, and then every year thereafter.
3. The Contractor shall obtain the Engineer's concurrence prior to using construction equipment equipped with Global Navigation Satellite System (GNSS) or Robotic Total Station (RTS) controlled by an AMG system in the construction of subgrade, subbase and base course aggregate courses, or other construction operations.
4. Tools and supplies shall be of the type and quality suitable for survey work.
5. Stakes and hubs shall be of a sufficient length to provide a solid set in the ground, with sufficient surface area above ground for necessary legible and durable markings.

III General Requirements:

1. The Contractor's Construction Schedule shall include dates and sequences of major surveying

activities in accordance with 1.20-1.05.08 for Facilities Construction.

2. The Department will furnish the initial horizontal control points, vertical control points and data for use in establishing control for completion of the work. The Contractor shall recover and preserve the initial reference and control points and shall notify the Engineer of missing control points.
3. The Department will furnish data relating to horizontal and vertical alignments, theoretical slope staking catch points, and other design data. The Contractor is responsible for reformatting and any additional calculations that may be required for the convenient use of the State-furnished data. The Contractor shall provide immediate notification of apparent errors or omissions in the initial staking or in the State-furnished data.
4. The Contractor shall provide survey data and measurements in the format(s) acceptable to the Engineer and submit on a schedule determined by the Engineer. Field data and supporting documentation will become the property of the Department upon completion of the work.
5. Prior to major surveying activities, a survey coordination meeting shall be held, and the following agenda items shall be discussed and coordinated with the Engineer:
 - A. Surveying and staking methods;
 - B. Stake marking;
 - C. Grade control for courses of material;
 - D. Referencing;
 - E. Structure control;
 - F. Field staking data;
 - G. Localization of the GNSS systems to the Department-established control points;
 - H. Protection of existing survey markers; and
 - I. Other procedures and controls necessary for the work.
6. The Contractor shall not start the physical work until the required survey or three-dimensional (3D) verification data for the affected work has been reviewed by the Engineer. Review of the construction survey does not relieve the Contractor of responsibility for correcting errors and omissions discovered during the work and for bearing additional costs associated with the error or omission.
7. The Contractor shall maintain legibility of survey markings for the duration of the Project or until notified by the Engineer.
8. Upon completion of the Project, the Contractor shall remove and dispose of all staking material used on the Project.
9. Should the establishment or re-establishment of property acquisition lines, highway lines, or non-access lines be required, the Contractor shall notify the Engineer at least two (2) weeks in advance of need.
10. The Contractor shall provide and maintain safe facilities for convenient access by Department forces to all survey stakes, control points, batter boards, and references.

IV Specific Requirements:

1. **Control points:** The Contractor shall
 - A. Relocate initial horizontal and vertical control points in conflict with construction to areas that will not be disturbed by construction operations.
 - B. Furnish the coordinates, elevations, and support documentation for the relocated points before the initial points are disturbed.
 - C. Set durable markers for survey control that uniquely identifies the points.
 - D. Furnish the GNSS localization results at least seven (7) days before beginning construction layout survey work. If necessary, the GNSS localization calibration and associated 3D model shall be broken into two or more zones to maintain the localized relationship between control points and original ground.
2. **Centerline establishment:** The Contractor shall establish or reestablish centerline at roadway design cross-section locations as necessary to construct the work.
3. **Original ground topographic verification:** In areas where the plan existing ground elevation and the actual ground elevation are not within a tolerance of ± 0.25 feet, the Contractor shall immediately notify the Engineer.
4. **Horizontal Slope Limits and Reference Stakes:** The Contractor shall
 - A. At a minimum, set stakes on both sides of centerline at the horizontal slope limit at cross-section intervals.

- B. When the slope is designed with a roll at the top and toe, two stakes shall be set on each side of the roadway, one to mark the intersection of the normal cut or fill with existing ground and the other to determine the limit of the roll.
5. **Clearing and Grubbing Limits:** The Contractor shall set clearing and grubbing limits on both sides of centerline.
6. **Finish-grade stakes:** The Contractor shall
- A. Set finish-grade stakes for grade elevations and horizontal alignment, on centerline and on each shoulder at design roadway cross-section intervals.
 - B. Reset finish-grade stakes as many times as necessary for construction of the roadway.
 - C. When the centerline curve radius is less than or equal to 250 feet, use a maximum spacing between stakes of 25 feet.
 - D. When the centerline curve radius is greater than 250 feet, use a maximum spacing between stakes of 50 feet.
7. **Structures:** The Contractor shall provide survey and staking data in accordance with the above requirements for Structures as follows:
- A. **Culverts:** Verify and set culvert locations at the inlet, outlet, and inlet basin points according to the plans. If the proposed culvert design does not fit field conditions, notify the Engineer and provide the following:
 - i. Surveyed ground profile along the culvert centerline;
 - ii. Slope catch points at the inlet and outlet.
 - B. **Bridges:** Set adequate horizontal, vertical, reference and Working Points for bridge substructure and superstructure components. Field verify the girders, bridge chord, bridge tangent, or control lines are as specified on the bridge plans. Also establish and reference the centerline of each pier, bent, and abutment.

The Contractor shall establish the center line of bearings for all bridge abutments and piers, by setting offset hubs or reference points, so located and protected to ensure they remain undisturbed until such time as they are no longer needed. The Contractor shall mark the location of anchor bolts to be installed, establish the elevation of bearing surfaces and check bearing plates to ensure installation at their proper elevation. Before the erection of structural steel or concrete beams the Contractor shall verify the locations, both vertically and horizontally, of all bearings and the distances between associated bearings.

The Contractor shall be responsible for conducting all surveys to verify the structural steel profile and alignment are as specified. The Contractor must submit survey and verification in a form acceptable to the Engineer a minimum of 7 days prior to installing the falsework and forms.
 - C. **Retaining walls and Reinforced Soil Slopes:** The Contractor shall set adequate horizontal, vertical, reference and Working Points to perform the work.
8. **Borrow and Waste sites:** The Contractor shall
- A. Perform field work necessary for initial layout and measurement of borrow or waste sites.
 - B. Establish site limits and clearing limits.
 - C. Measure both original and final ground conditions and submit cross-sections as directed by the Engineer.
9. **Utility Relocations:** The Contractor shall provide additional reference stakes to assist the Engineer and public utility personnel to accurately identify the proposed locations for utility facilities to be relocated. At least 2 weeks prior to the scheduled relocation of public utilities, the Contractor shall stake out the following features throughout the limits of utility relocations at a maximum spacing of 25 feet, unless directed otherwise by the Engineer:
- A. Edge of road on the side adjacent to the proposed utility relocations.
 - B. Both edges of sidewalks, where shown on the plans.
 - C. Proposed drainage location(s) and invert elevation(s) at proposed utility locations.
 - D. Finished grade where existing utility facilities will be reset or relocated.
10. **Regulated Areas:** The Contractor shall install and maintain reference stakes at 25 foot spacing, or as directed by the Engineer, along the permitted permanent or temporary regulated impacted areas depicted in the permit applications. Each stake shall be legibly marked identifying the baseline station and offset, and the feature it represents.
11. **Pavement Markings:** Prior to any resurfacing or obliteration of existing pavement markings, the Contractor and a representative of the Engineer shall establish and document pavement marking control points from the existing markings within the limits of the proposed pavement markings or

pavement marking grooves. These control points shall be used to reestablish the positions of the lanes, the beginnings and endings of tapers, channelization lines for on- and off-ramps, lane-use arrows, stop bars, driveways, private drives, road entrances, and any lane transitions in the Project area, including all line striping grooving. The Contractor shall use these control points to provide appropriate pre-marking prior to the installation of final markings, including grooves.

The Contractor shall provide and maintain reference stakes or markings immediately off the edge of pavement, at 100 foot intervals and at any point where there is a change in pavement markings. If the Contractor proposes an alternative method to establish and document pavement marking control points, it must be approved by the Engineer.

For roadways where the existing pavement markings need to be reestablished or pavement marking grooves are to be installed on non-limited access roadways, the markings shall be adjusted as directed by the Engineer. These adjustments are to provide wider shoulders to accommodate pedestrian and bicycle traffic while maintaining through travel lane widths of no less than 11 feet.

Unless otherwise noted in the Project documents, lane and shoulder widths for commonly encountered half sections shall be established as shown in the table below:

Centerline to curb or edge of road	Lane width	Shoulder width
12 to 16 feet	11 feet	Remaining Pavement
17 to 20 feet	12 feet	Remaining Pavement

For Projects that only consist of removal and replacement of pavement markings, the requirement for a licensed land surveyor to supervise the staking is waived.

- 12. **Miscellaneous survey and staking:** The Contractor shall survey and stake other work such as guiderail, curb and gutter, seeding, regulated areas, watercourses and excavation limits for structures. When staking increments are not specified, the Contractor shall propose increments for the Engineer’s review. The Contractor shall maintain or replace these stakes until the Engineer approves their removal.

**Table 1.20-9.80-1
Construction Survey Staking Tolerances¹**

Staking Phase	Horizontal	Vertical
Control points set from existing control points. ²	±0.03 feet	±0.01 feet × √N
Centerline points including all points of curvature and references.	±0.06 feet	±0.03 feet
Slope-stake and slope-stake references. ³	±0.25 feet	±0.25 feet
Culverts, ditches, and minor drainage structures stakes.	±0.25 feet	±0.06 feet
Retaining walls stakes.	±0.06 feet	±0.03 feet
Bridge substructures and superstructure stakes. ⁴	±0.03 feet	±0.03 feet
Pavement markings stakes. ⁵	±0.50 feet	N/A
Curb and gutter stakes.	±0.06 feet	±0.03 feet
Working Points. ⁴	±0.03 feet	N/A
Clearing and grubbing limit stakes.	±1.00 feet	N/A
Roadway subgrade finish stakes.	±0.16 feet	±0.03 feet
Roadway finish grade stakes.	±0.16 feet	±0.03 feet

¹ At statistical 95% confidence level. Tolerances are relative to existing control points.
² N is the number of instrument setups.
³ Take the cross-sections normal to the centerline ±1 degree.
⁴ Bridge control is established as a local network and the tolerances are relative to that network.
⁵ This tolerance also applies to alternative methods of establishing and documenting pavement marking control points from the existing markings, such as GPS recording.

- 13. For Facilities Construction:** Existing survey is not guaranteed. The Contractor shall:
- A. Investigate and verify the existence and location of underground utilities and other elements affecting the contract work before beginning site work.
 - B. Furnish information that is necessary to adjust, move or relocate existing structures, utility poles, lines, services, or other utility appurtenances affected by construction. Coordinate with authorities performing work and/ or having jurisdiction.
 - C. Verify layout information shown on the plans, in relation to the control points and existing benchmarks before proceeding to layout the Project work. Notify the Engineer if discrepancies are discovered. Preserve and protect permanent benchmarks and control points during construction operations. Do not change or relocate benchmarks or control points without the Engineer’s prior written approval. Promptly report lost or destroyed control points, or the need to relocate permanent benchmarks or control points because of necessary changes in grades or locations. Promptly replace lost or destroyed benchmarks and control points. Base replacements on the original survey control points.
 - D. Establish and maintain a minimum of (2) permanent benchmarks on the Project Site, referenced to data established by survey control points. Comply with authorities having jurisdiction for type and size of benchmark. Record benchmark locations, with horizontal and vertical data, on Project Record Documents. Provide temporary reference points sufficient to locate the work where the actual location or elevation of layout points cannot be marked. Remove temporary reference points when no longer needed. Restore marked construction to its original condition.
 - E. Work from lines and levels established by the control survey. Establish benchmarks and control points to set lines and levels at each area of construction as needed to locate each element of the Project. Calculate and measure required dimensions within indicated or recognized tolerances. Do not scale plans to determine dimensions. Advise entities engaged in construction activities, of marked lines and levels provided for their use. As construction proceeds, check every major element for line, level and plumb.
 - F. Locate and lay out site improvements, including pavements, stakes for grading, fill and topsoil placement, utility slopes and invert elevations by instrumentation and similar appropriate means. The Contractor shall identify and document by survey the extent, elevation, and location of all foundations and capped utilities to be left in place and backfilled. Appropriate scaled marked up drawings shall be furnished to the Engineer PRIOR to backfilling.
 - G. Locate and lay out control lines and levels for structures, building foundations, column grids and locations, floor levels including those required for mechanical and electrical work. Transfer survey markings and elevations for use with control lines and levels. Level foundations and piers from (2) or more locations.
 - H. Maintain a surveyor's log of control and other survey work. Make this log available to the Engineer for reference. Record deviations from required lines and levels, and advise the Engineer when deviations that exceed indicated or recognized tolerances are detected. On Project Record Drawings, record deviations that are accepted by the Engineer and not corrected. Record the location of utilities at the time of installation in the log as well as on the As-Built drawings for permanent record. The recording Land Surveyor shall place its registration seal and accuracy statement regarding location of exterior underground utility lines on the utility plans of As-Built drawings.

1.20-9.80.04—Facilities Construction - Method of Measurement: Construction Surveying, being paid on a lump sum basis, will not be measured for payment. Prior to beginning the work, the Contractor shall submit a proposed schedule of values for review and concurrence by the Engineer.

1.20-9.80.05—Facilities Construction - Basis of Payment: Construction Surveying will be paid for at the Contract lump sum price for "Construction Surveying," based on completed portions of the work. This price shall include all labor, submittals, maintenance, materials, tools, equipment, removal of materials and all work incidental thereto.

Pay Item	Pay Unit
Construction Surveying	l.s.

**SECTION 2.11
ANTI-TRACKING PAD**

Replace Section 2.11 with the following:

**SECTION 2.11
ANTI-TRACKING PAD**

2.11.01—Description

2.11.02—Materials

2.11.03—Construction Methods

2.11.04—Method of Measurement

2.11.05—Basis of Payment

2.11.01—Description: This work shall consist of furnishing, installing, maintaining, and removing, a crushed stone Anti-Tracking Pad on geotextile filter fabric. All disturbed areas affected by the Anti-Tracking Pad shall be restored to the original grade or as shown on the plan. If shown on the plans or ordered by the Engineer, the restored areas shall be stabilized with seeding.

2.11.02—Materials:

The crushed stone shall meet the gradation requirements of M.01.02 for No. 3 stone.

Geotextile filter fabric shall meet the requirements of 7.55 and M.08.01-19.

Topsoil, if necessary, shall meet the requirements of M.13.01.

Seed, if necessary, shall meet the requirements of M.13.04, or as specified on the plans.

Fertilizer, if necessary, shall meet the requirements of M.13.03.

Mulch, if necessary, shall meet the requirements of M.13.05.

2.11.03—Construction Methods: Clear area of Anti-Tracking Pad of all vegetation and excavate to a maximum depth of 4 inches. Place geotextile filter fabric over the full width and length of excavated area and cover with No. 3 crushed stone to a minimum depth of 6 inches.

The Anti-Tracking Pad shall be uniformly graded to produce the entry and exit path to the Site for all construction equipment. The Pad shall be maintained of sufficient grading and stone surface to capture all soils and sediment from equipment prior to such exiting from the Site.

Crushed stone shall be replenished or replaced as necessary or as ordered by the Engineer to assure sufficient capture of sediment at the construction Site. Any sediment or crushed stone tracked off the Site shall be immediately cleaned, swept and removed by the Contractor at no cost to the State.

2.11.04—Method of Measurement: This work will be measured for payment by the number of square yards of accepted anti-tracking pad completed as shown on the plans or as ordered by the Engineer.

2.11.05—Basis of Payment: Payment for this work will be made at the Contract unit price per square yard for "Anti-Tracking Pad," which shall include furnishing and placing all material, including the geotextile; for maintaining the Anti-Tracking Pad during the Project construction period; for removing the Anti-Tracking Pad after completion of the Project; for restoring the Site, including any required seeding; and for all labor, equipment, tools, and incidentals required to complete the work as well as the cleaning and sweeping of any sediment or crushed stone tracked off the Site.

Clearing and grubbing required to install the Anti-Tracking Pad will be paid under the item "Clearing and Grubbing."

Pay Item	Pay Unit
Anti-Tracking Pad	s.y.

SECTION 2.86
DRAINAGE TRENCH EXCAVATION,
ROCK IN DRAINAGE TRENCH EXCAVATION

Replace Subarticle 2.86.03-4 with the following:

- (4) **Backfill:** Suitable material excavated from the drainage trench shall be used as backfill material prior to consideration of using any other source of backfill. Backfill material used shall be of a quality satisfactory to the Engineer and shall be free from large or frozen lumps, wood and other extraneous material. Rock fill or stones larger than 5 inches shall not be placed within 1 foot of the drainage structure or pipe. The grading shall be completed to the lines shown on the plans, or as ordered, by refilling to the required elevation with approved material, placed in layers not to exceed 6 inches in depth after compaction, which shall be thoroughly compacted with equipment approved by the Engineer. **Material placed around pipes shall be deposited on both sides to approximately the same elevation at the same time.**

All surplus or unsuitable material shall be removed and disposed of as directed. Should additional material be required for backfilling, it may be obtained from the Project surplus excavation in accordance with 2.02.03-8 or from borrow pits, gravel pits, or elsewhere as directed by the Engineer.

**SECTION 4.01
CONCRETE FOR PAVEMENT**

Delete Section 4.01 in its entirety.

SECTION 4.06
BITUMINOUS CONCRETE

After “Job Mix Formula (JMF)” in Article 4.06.01 add the following:

Leveling Course: A thin lift of HMA placed at an average consistent thickness, usually about an inch, as indicated on the plans to correct minor variations in the contour of the existing pavement surface.

After “Warm Mix Asphalt (WMA) Technology” in Article 4.06.01 add the following

Wedge Course: A lift or multiple lifts of HMA placed at a varying thickness as indicated on the plans to increase or decrease the cross slope of the existing pavement surface.

Replace 4.06.03-6 with the following:

6. Spreading and Finishing of Mixture: Prior to the placement of the mixture, the underlying base course shall be brought to the plan grade and cross section within the allowable tolerance.

Immediately before placing a bituminous concrete lift, a uniform coating of tack coat shall be applied to all existing underlying pavement surfaces and on the exposed surface of a wedge joint. Such surfaces shall be clean and dry. Sweeping or other means acceptable to the Engineer shall be used.

The mixture shall not be placed whenever the surface is wet or frozen.

Tack Coat Application: The tack coat shall be applied by a pressurized spray system that results in uniform overlapping coverage at an application rate of 0.03 to 0.05 gal./s.y. for a non-milled surface and an application rate of 0.05 to 0.07 gal./s.y. for a milled surface. The Engineer must approve the equipment and the method of measurement prior to use. The material for tack coat shall be heated to $160^{\circ}\text{F} \pm 10^{\circ}\text{F}$ and shall not be further diluted.

Tack coat shall be allowed sufficient time to break prior to any paving equipment or haul vehicles driving on it.

The Contractor may request to omit the tack coat application between bituminous concrete layers that have not been exposed to traffic and are placed during the same work shift. Requests to omit tack coat application on the upper and lower surfaces of a wedge joint will not be considered.

Placement: The mixture shall be placed and compacted to provide a smooth, dense surface with a uniform texture and no segregation at the specified thickness and dimensions indicated in the plans and specifications.

When unforeseen weather conditions prevent further placement of the mixture, the Engineer is not obligated to accept or place the bituminous concrete mixture that is in transit from the Plant.

In advance of paving, traffic control requirements shall be set up, maintained throughout placement, and shall not be removed until all associated work is completed, including quality control, sampling for density testing, and inspection activities.

The mixture temperature will be verified using three infrared thermometers supplied by the Contractor and acceptable to the Engineer. The placement temperature range shall be listed in the Quality Control Plan (QCP) for placement and shall meet the requirements of Table M.04.03-4. Any HMA material that falls outside the specified temperature range as measured by two of the three thermometers may be rejected.

The Contractor shall inspect the newly placed pavement for defects in mixture or placement before rolling is started. Any deviation from standard crown or section shall be immediately remedied by placing additional mixture or removing surplus mixture. Such defects shall be corrected to the satisfaction of the Engineer.

Where it is impracticable due to physical limitations to operate the paving equipment, the Engineer may permit the use of other methods or equipment. Where hand spreading is permitted, the mixture shall be placed by means of suitable shovels and other tools, and in a uniformly loose layer at a thickness that will result in a completed pavement meeting the designed grade and elevation.

Placement Tolerances: Each lift of bituminous concrete placed at a specified thickness shall meet the following requirements for thickness and area. Any pavement exceeding these limits shall be subject to an adjustment or removal. Lift tolerances will not relieve the Contractor from meeting the final designed grade. Lifts of specified non-uniform thickness, i.e. wedge course, shall not be subject to thickness and

area adjustments.

- a) Thickness: Where the average thickness of the lift exceeds that shown on the plans beyond the tolerances shown in Table 4.06-3, the Engineer will calculate the thickness adjustment in accordance with 4.06.04.

TABLE 4.06-3: Thickness Tolerances

Mixture Designation	Lift Tolerance
S1	+/- 3/8 inch
S0.25, S0.375, S0.5	+/- 1/4 inch

Where the thickness of the lift of mixture is less than that shown on the plans beyond the tolerances shown in Table 4.06-3, the Contractor, with the approval of the Engineer, shall take corrective action in accordance with this Section.

- b) Area: Where the width of the lift exceeds that shown on the plans by more than the specified thickness, the Engineer will calculate the area adjustment in 4.06.04.
- c) Delivered Weight of Mixture: When the delivery ticket shows that the truck exceeds the allowable gross weight for the vehicle type, the Engineer will calculate the weight adjustment in accordance with 4.06.04.

Transverse Joints: All transverse joints shall be formed by saw-cutting to expose the full thickness of the lift. Tack coat shall be applied to the sawn face immediately prior to additional mixture being placed.

Compaction: The Contractor shall compact the mixture to meet the density requirements as stated in 4.06.04 for any lift placed with a thickness of 1 1/2 inches or greater, and eliminate all roller marks without displacement, shoving, cracking, or aggregate breakage. This shall include wedge courses when the wedge thickness is 1 1/2 inches or greater within a single paver pass.

When placing a lift with a specified thickness less than 1 1/2 inches the Contractor shall provide a minimum rolling pattern as determined by the development of a compaction curve. This shall include wedge courses when the wedge or any portion of the wedge thickness is less than 1 1/2 inches within a single paver pass. The procedure to be used shall be documented in the Contractor's QCP for placement and demonstrated on the first day of placement.

The use of the vibratory system on concrete structures is prohibited. When approved by the Engineer, the Contractor may operate a roller using an oscillatory system at the lowest frequency setting.

If the Engineer determines that the use of compaction equipment in the dynamic mode may damage highway components, utilities or adjacent property, the Contractor shall provide alternate compaction equipment.

Rollers operating in the dynamic mode shall be shut off when changing directions.

These allowances will not relieve the Contractor from meeting pavement compaction requirements.

Surface Requirements:

Each lift of the surface course shall not vary more than 1/4 inch from a Contractor-supplied 10 foot straightedge. For all other lifts of bituminous concrete, the tolerance shall be 3/8 inch. Such tolerance will apply to all paved areas.

Any surface that exceeds these tolerances shall be corrected by the Contractor at its own expense.

Replace "Method II – Butt Joint" under Subarticle 4.06.03-7 with the following:

Method II - Butt Joint:

When adjoining passes are placed, the Contractor shall use the end gate to create a near vertical edge (refer to Figure 4.06-2). The completing pass (hot side) shall have sufficient mixture so that the compacted thickness is not less than the previous pass (cold side). During placement of multiple lifts, the longitudinal joint shall be constructed in such a manner that it is located at least 6 inch from the joint in the lift immediately below. The joint in the final lift shall be at the centerline or at lane lines. The end gate on the paver should be set so there is an overlap onto the cold side of the joint.

When using this method, the Contractor must complete full width "curb to curb" paving when the vertical edge exposed to traffic would be greater than one inch, unless otherwise allowed by the Engineer.

Replace paragraphs 10, 11 and 12 under Subarticle 4.06.03-8 with the following:

Approval of any QCP does not relieve the Contractor of its responsibility to comply with the Project specifications. The Contractor may propose modifications to the QCPs as work progresses and must document the changes in writing prior to resuming operations. These modifications include changes in quality control procedures, equipment, or personnel.

QCP for Production: Refer to M.04.03-1.

QCP for Placement: The Standard QCP, Project Summary Sheet, and Extended Season Paving Plan shall conform to the format provided on the [Advisory Team web page](#).

Replace Subarticle 4.06.03-9 with the following:

9. Temperature and Seasonal Requirements: Paving, including placement of temporary pavements, shall be divided into 2 seasons, “In-Season” and “Extended-Season.” In-Season paving occurs from May 1 to October 14, and Extended Season paving occurs from October 15 to April 30. The following requirements shall apply unless otherwise authorized or directed by the Engineer:

- Mixtures shall not be placed when the air or subbase temperature is less than 40°F regardless of the season.
- Should paving operations be scheduled during the Extended Season, the Contractor must submit an Extended Season Paving Plan for the Project that addresses minimum delivered mix temperature and meets the requirements of Table M.04.03-4. The Plan shall also include if WMA, PMA, or other additives are being used; maximum paver speed; enhanced rolling patterns; and the method to balance mixture delivery and placement operations. Paving during Extended Season shall not commence until the Engineer has approved the plan.

Replace paragraphs 1 and 2 under Subarticle 4.06.03-10 with the following:

10. Field Density: The Contractor shall obtain cores in accordance with AASHTO R 67 for the determination of mat and longitudinal joint density of bituminous concrete pavements. The Contractor’s representative obtaining samples must be a certified NETTCP HMA Paving Inspector, NETTCP HMA Plant Technician, or has successfully completed the HMA Field Sampling Course administered by The Connecticut Advanced Pavement Laboratory (CAP Lab). Within three (3) calendar days of placement, mat and joint cores shall be extracted on each lift with a specified thickness of 1 1/2 inches or more. That time frame may be extended to a maximum of five (5) days due to inclement weather, State holidays or other access restrictions beyond the control of the Contractor. Joint cores shall not be extracted on HMA S1.0 lifts.

The Contractor shall extract cores from random locations determined by the Engineer in accordance with ASTM D3665. Six (6) inch diameter cores shall be extracted for all mixes. The Contractor shall coordinate with the Engineer to witness the extraction, labeling of cores, and filling of the core holes.

Replace the last sentence in Subarticle 4.06.04-2(b)i with the following:

Additionally, any subplot with a density result below 87% is subject to evaluation under 1.06.04.

Replace the last sentence in Subarticle 4.06.04-2(b)ii with the following:

Additionally, any subplot with a density result below 87% is subject to evaluation under 1.06.04.

Replace the last sentence in Subarticle 4.06.04-2(b)iii with the following:

Additionally, any subplot with a density result below 87% is subject to evaluation under 1.06.04.

After Section 4.06, add the following New Section 4.07:

**SECTION 4.07
RUMBLE STRIPS,
REMOVAL OF RUMBLE STRIPS**

4.07.01—Description

4.07.02—Materials

4.07.03—Construction Methods

4.07.04—Method of Measurement

4.07.05—Basis of Payment

4.07.01—Description: Work under this item shall consist of installing rumble strips on asphalt highway shoulders where shown on the plans or where directed by the Engineer.

Work under this item shall also consist of removing rumble strips by milling the pavement to a depth of 2 1/4 inches, disposing of pavement millings, sweeping and cleaning, applying tack coat on all surfaces within the milled area, and placing Hot-Mix Asphalt (HMA) or an equivalent Polymer Modified Asphalt (PMA) to match the elevation of the surrounding pavement.

4.07.02—Materials: Materials for the removal of rumble strips shall meet the requirements of Section M.04 and shall consist of the following:

1. HMA S0.375 or an equivalent PMA. All HMA or PMA shall be Traffic Level 2 unless indicated otherwise on the plans.
2. Material for Tack Coat.

4.07.03—Construction Methods:

I. Installation of Rumble Strips:

The Contractor shall pre-mark the location of the edge of the cut, and the beginning and ending points of the sections, prior to the installation of the rumble strips. The Engineer will review and approve the locations.

The Contractor shall arrange for a technical representative, from the company which produces the milling machine to be used on the Project, who will be required to be on Site at the beginning of the operation in order to ensure results that meet the requirements of the Contract to the satisfaction of the Engineer.

Rumble strips shall not be installed on bridge decks, in acceleration and deceleration lanes, at drainage structures, at loop detector sawcut locations, or in other areas identified by the Engineer.

- a. **Automated (Wide Shoulders):** The equipment shall be able to install the rumble strips in sections where the shoulder width from the edge line to an obstruction is greater than or equal to 4 feet. Where there are no obstructions, the equipment shall be used in sections where the shoulder width from the edge line is a minimum of 3 feet. The equipment shall consist of a rotary type cutting head with a maximum outside diameter of 24 inches and shall be a minimum of 16 inches long. The cutting head(s) shall have the cutting tips arranged in such a pattern as to provide a relatively smooth cut (approximately 1/16 of an inch between peaks and valleys) in one pass. The cutting head(s) shall be on independent suspension from that of the power unit to allow the tool to self-align with the slope of the shoulder or any irregularities in the shoulder surface. The equipment shall include suitable provisions for the application of water to prevent dust. The Contractor shall use a machine capable of creating the finished pattern at a minimum output of 60 rumble strips per minute.
- b. **Manual (Narrow Shoulders):** The equipment shall be able to install the rumble strips in sections where the shoulder width from the edge line to an obstruction is between 3 feet and 4 feet. The cutting head(s) shall have the cutting tips arranged in such a pattern as to provide a relatively smooth cut (approximately 1/16 of an inch between peaks and valleys) in one pass. The equipment shall include suitable provisions for the application of water to prevent dust.
- c. **Finished Cut (Automated or Manual):** The rumble strips shall have finished dimensions of 7 inches (+/- 1/2 inch) wide in the direction of travel and shall be 16 inches (+/- 1/2 inch) long measured perpendicular to the direction of travel. The depressions shall have a concave circular shape with a minimum 1/2 inch depth at center (maximum allowable depth is 5/8 inch measured to a valley). The rumble strips shall be placed in relation to the roadway according

to the patterns shown in the plans or in Figure 4.07-1. Alignment of the edge of the cut shall be checked and verified by the Engineer.

The cutting tool shall be equipped with guides to provide consistent alignment of each cut in relation to the roadway.

The Contractor shall pick up any waste material resulting from the operation in a manner acceptable to the Engineer. This waste material shall be disposed of in accordance with Article 1.10.03.

The work area shall be returned to a debris-free state prior to re-opening to traffic.

The Contractor shall provide all traffic control as specified in the item "Maintenance and Protection of Traffic" included elsewhere in the Contract.

II. Removal of Rumble Strips:

Equipment for this work shall include the following:

1. Milling machine: A milling machine designed and built for milling flexible pavements. It shall be self-propelled with sufficient power, traction, and stability to maintain depth and slope and shall be capable of removing the existing bituminous concrete pavement.
The rotary drum of the machine shall use carbide or diamond-tipped tools. A tooth spacing of 8 mm is preferred, but up to 15 mm will be allowed. The forward speed of the milling machine shall be a maximum of 45 feet/minute. The tools on the revolving cutting drum must be continually maintained and shall be replaced as warranted to provide a uniform pavement texture.
The machine shall be equipped with an integral pickup and conveying device to immediately remove milled material from the surface of the roadway and discharge the millings into a truck in one operation. The machine shall also be equipped with a means of effectively limiting the amount of dust escaping from the milling and removal operation. When milling smaller areas or areas where it is impractical to use the above described equipment, the Contractor may be permitted to use a lesser-equipped milling machine, if approved by the Engineer. It shall be capable of milling a minimum width of 20 inches to completely remove the existing rumble strip. A wider milling width may be used in cases where two rumble strips are located near and parallel to each other, as may occur in a median area.
2. 10-foot straight edge.
3. Sweeper: A sweeper, equipped with a water tank, capable of remove millings and loose debris from the surface. Other sweeping or vacuum type equipment may be provided in lieu of the sweeper where acceptable by the Engineer. A hand broom may be used for smaller areas when approved by the Engineer.
4. Air compressor: An air compressor capable of producing 100 psi oil free compressed air for cleaning the milled pavement surface.
5. Hot air lance: A hot air lance that can deliver 100 psi oil free heated air to clean and dry the pavement surface. The compressed air emitted from the tip of the lance shall achieve a temperature of at least 1500°F.
6. Paving and compaction equipment: Paving and compaction equipment meeting the requirements of Section 4.06. It is expected that much of the placement will require hand work or a mixture of equipment and hand tools to achieve the required results. Smaller compaction equipment, including vibratory plate compactors, will be allowed by the Engineer to achieve the required results. At all times the Contractor is required to meet the density and compaction and all other requirements specified in Sections 4.06 and M.04.
7. Portable lighting equipment: If the work is performed at night a truck-towed light tower and driver shall be provided for use by the Engineer for all marking, installation, and inspection of the patches.
8. Tack Coat Distributor: A minimum 150-gallon capacity tank that is trailer mounted or self-propelled and capable of applying tack coat meeting the requirements of Section 4.06.

The Contractor shall mark the location of the beginning and ending points of the sections for milling and paving, prior to the removal of the rumble strips. The Engineer will review and approve the limits of removal.

The width of milling shall be as specified on the Plans or other specifications. If no other width specification exists, the minimum width of milling for freeway shoulders shall be 20 inches, and for all other rumble strips the minimum width of milling shall be 14 inches in order to completely remove

the existing rumble strip to the satisfaction of the Engineer. If there are two rumble strips located near and parallel to one another, as may occur in median areas, and if they both can be removed by a single pass of a wider milling machine without adversely affecting drainage, safety, or quality of results, then a wider milling machine may be used. In this case the length measured for payment will be the sum of the lengths of the two individual rumble strips. Milling widths wider than specified above may be used with the written permission of the Engineer.

The depth of removal shall be 2 1/4 inches. The Engineer may alter the milling depth, either up or down, based on deterioration or scabbing discovered as work is in progress. This adjustment will not exceed 1/2 inch. It is expected that the milling depth of 2 1/4 inches is appropriate for most cases. The milled surface shall be swept clean (by hand if necessary). Once all millings are removed by sweeping, the milled areas shall be allowed to dry. Any moisture in or on the milled areas must be allowed to evaporate or be removed with the assistance of a hot air lance as specified above. When the milled area is dry to the satisfaction of the Engineer, it shall be blown clean of any residual dust or debris using compressed air.

Once deemed clean and dry by the Engineer, the entire milled area, including the sides/walls of the milled area, shall receive an application of tack coat as specified above and in Section 4.06.

After the tack coat has had sufficient time to cure or break, HMA S0.375 (Traffic Level 2) or an equivalent PMA shall be placed and compacted to the requirements above and in Section 4.06. The Contractor shall confirm that the surface elevation of the finished patch matches the elevation of the surrounding pavement surface to within 1/4 inch using the 10-foot straightedge. The Contractor shall confirm that all patch material placed is uniform in appearance without segregation.

The Contractor shall resurface the milled area prior to opening the roadway to traffic. The milled area shall be swept, cleaned, tacked, and repaved in the same work shift.

Precautions shall be taken to avoid damage to the existing roadway materials that are to remain in place. If damage occurs, it must be repaired by the Contractor at no additional cost to the State. The methods employed in performing the work and all equipment, tools, machinery and plant used in handling material and executing any part of the work shall be subject to the approval of the Engineer before the work is started; and whenever found unsatisfactory, it shall be changed and improved as required by the Engineer.

The Contractor shall remove and dispose of any waste material resulting from the operation in a manner acceptable to the Engineer. This waste material shall be disposed of in accordance with Article 1.10.03.

4.07.04—Method of Measurement: The work for installing and removing rumble strips will be measured for payment by the actual number of linear feet of rumble strips installed or removed, as applicable. Removal distance shall be measured longitudinally along the edge of pavement with deductions for bridge decks, acceleration and deceleration lanes, drainage structures, loop detector sawcut locations, and other sections where the rumble strips were not previously installed.

If two rumble strips are near one another and are removed by a single milling machine pass, the length measured for payment will be the sum of the lengths of the two rumble strips.

4.07.05—Basis of Payment: The work for installing rumble strips will be paid for at the Contract unit price per linear foot for "Rumble Strips –Automated" or "Rumble Strips–Manual." The price shall include furnishing all equipment, tools, labor, a technical representative and work incidental thereto and also disposal of any waste material resulting from the operation. The Contractor will not be paid under the item "Rumble Strips - Manual" if the field conditions allow for the use of the "Rumble Strips - Automated" item, even if the manual method was used.

The work for removing rumble strips will be paid for at the Contract unit price per linear foot for "Removal of Rumble Strips." The price shall include the removal of the existing rumble strips by milling, sweeping, cleaning, and drying of the milled area, furnishing all materials, application of tack coat, placement and compaction of the HMA or PMA, and equipment, tools, labor, and work incidental thereto, as well as removal and disposal of any waste material resulting from the operation.

Pay Item	Pay Unit
Rumble Strips–Automated	l.f.
Rumble Strips–Manual	l.f.
Removal of Rumble Strips	l.f.

Figure 4.07-1: DETAILS AND SECTIONS OF RUMBLE STRIPS

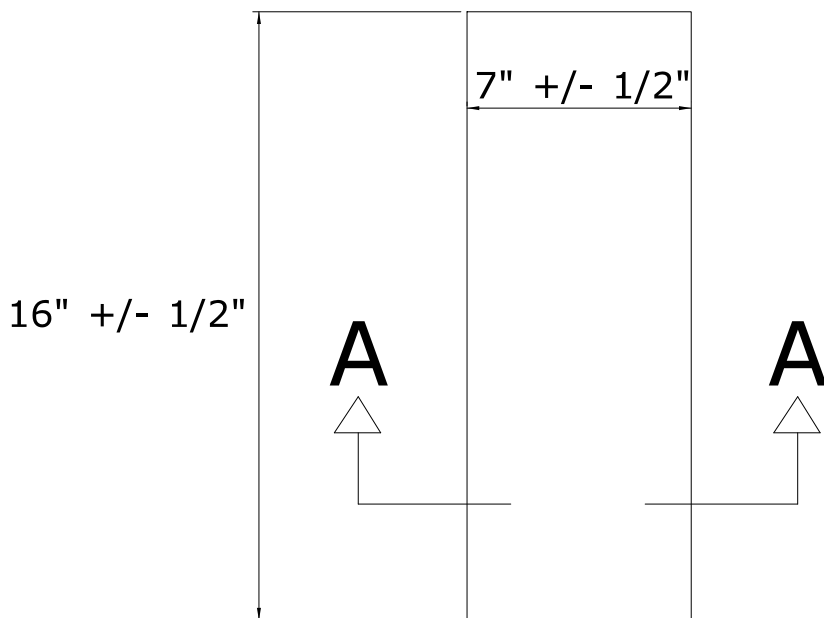
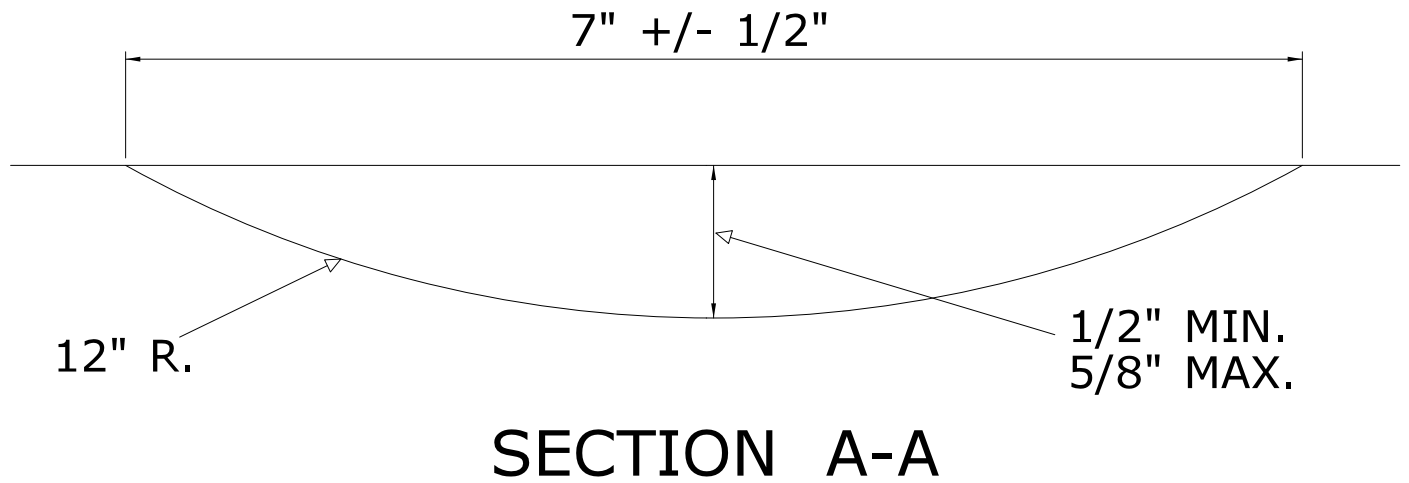
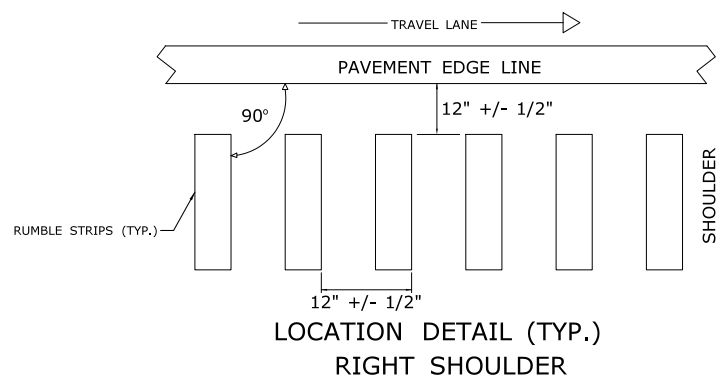
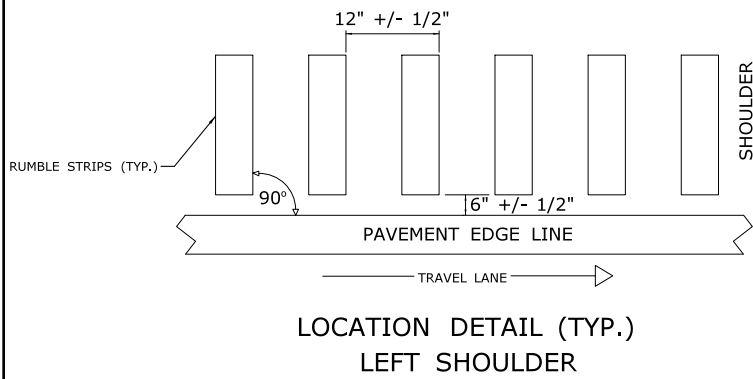

NOTES:

RUMBLE STRIP ALIGNMENT SHALL GENERALLY BE STRAIGHT AND OFFSET APPROXIMATELY 6" IN THE LEFT SHOULDER AND 12" IN THE RIGHT SHOULDER FROM THE OUTER EDGE OF THE EDGE LINE, AND SHALL BE AT LEAST 12" FROM THE LONGITUDINAL JOINT IN COMPOSITE PAVEMENTS. THIS OFFSET MAY BE ADJUSTED TO ACCOMMODATE VARIATIONS IN THE EDGE LINE AND THE SHOULDER WIDTH.

PLAN DETAIL

Figure 4.07-2: TYPICAL TREATMENTS FOR INSTALLING RUMBLE STRIPS

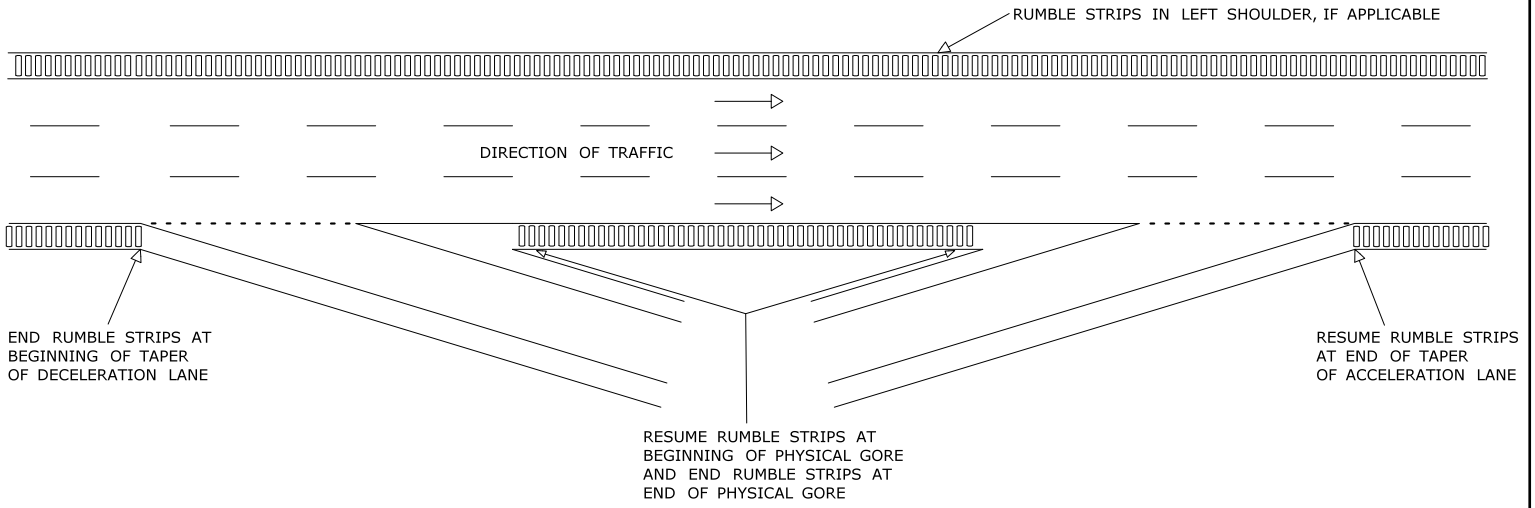

TYPICAL TREATMENT FOR RAMPS

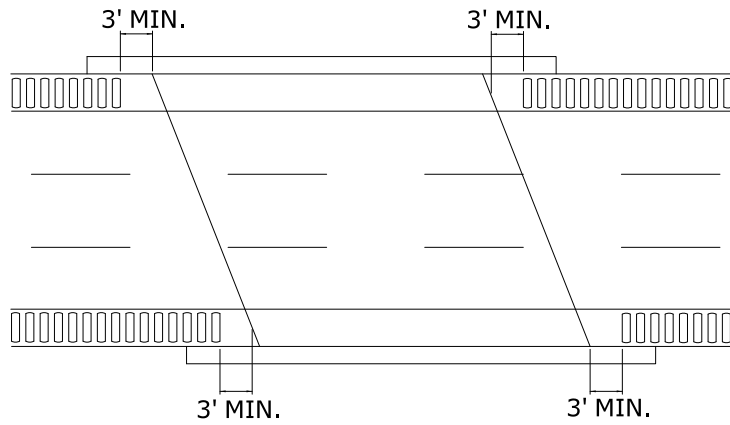

TYPICAL TREATMENT FOR BRIDGES

NOTE: REVISE DISTANCE FROM EXPANSION JOINT AS NEEDED FOR NARROW SHOULDERS APPROACHING BRIDGES

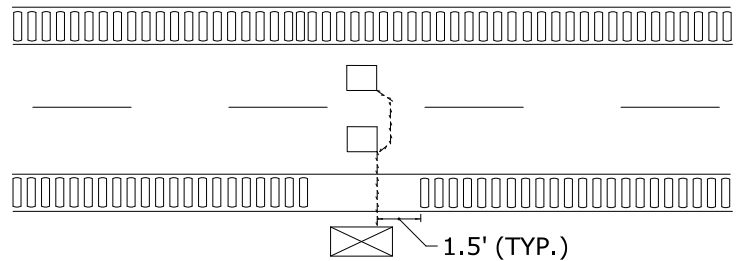

TYPICAL TREATMENT FOR LOOP DETECTOR SAWCUT LOCATIONS

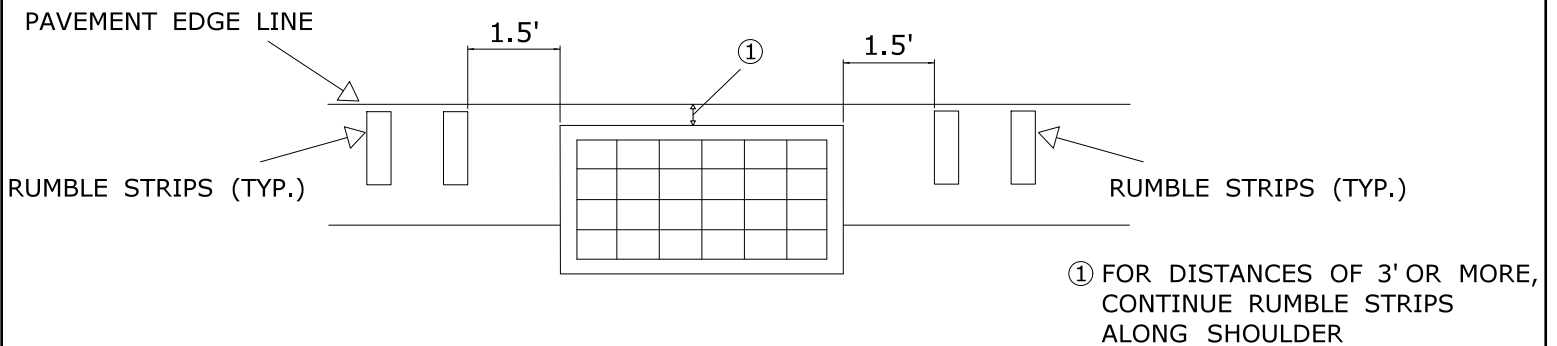

TYPICAL TREATMENT FOR OBSTRUCTIONS (I.E. CATCH BASINS OR MANHOLES)

**SECTION 4.09
MILLING,
REMOVAL OF EXISTING WEARING SURFACE**

Replace Section 4.09 in its entirety with the following:

**SECTION 4.09
MILLING,
REMOVAL OF EXISTING WEARING SURFACE**

4.09.01—Description: This work shall consist of the milling, removal, and disposal of existing bituminous concrete pavement. It shall also include the complete removal and disposal of the existing bituminous concrete wearing surface, membrane waterproofing and bond breaker covering the reinforced concrete bridge deck(s) as shown on the plans or as ordered by the Engineer. The types of milling shall include the following:

1. **Coarse** Milling shall be used for the removal of bituminous concrete in excess of 4 inch depth.
2. Fine Milling shall be used to remove bituminous concrete from 0 to 4 inches. It may also be used to remove bituminous concrete greater than 4 inches in limited areas or where required.
3. Removal of Existing Wearing Surface shall be used where shown on the plans.

4.09.03—Construction Methods:

A. Milling:

1. General: The Contractor shall remove the bituminous concrete material using the milling type specified on the Plans. The pavement surface shall be removed to the line, grade, and existing or typical cross-section shown on the plans or as directed by the Engineer.

The bituminous concrete material shall be disposed of offsite by the Contractor at an approved disposal facility unless otherwise stated in the Contract.

Any milled surface, or portion thereof, that is exposed to traffic shall be paved within 14 calendar days unless otherwise stated in the Contract.

2. Equipment: The equipment for milling the pavement surface shall be designed and built for milling bituminous concrete pavements. It shall be self-propelled with sufficient power, traction, and stability to maintain depth and slope and shall be capable of removing the existing bituminous concrete pavement.

The milling machine shall be equipped with a built-in automatic grade averaging control system that can control the longitudinal profile and the transverse cross-slope to produce the specified results. The longitudinal controls shall be capable of operating from any longitudinal grade reference, including string line, **mobile reference beam** (20 feet minimum), or mobile string line (30 feet minimum). The transverse controls shall have an automatic system for controlling cross-slope at a given rate. The Engineer may waive the requirement for automatic grade or slope controls where the situation warrants such action.

The machine shall be equipped with an integral pickup and conveying device to immediately remove material being milled from the surface of the roadway and discharge the millings into a truck, all in one operation. The machine shall also be equipped with a means of effectively limiting the amount of dust escaping from the milling and removal operation.

When milling smaller areas or areas where it is impractical to use the above described equipment, the use of a lesser equipped milling machine may be permitted when approved by the Engineer.

The rotary drum of the milling machine shall have carbide or diamond-tipped teeth with the following maximum spacing and minimum milling depth:

Milling Type	Maximum Tooth Spacing*	Minimum Depth Capability (single pass)
Coarse Milling	15 mm	4 inches
Fine Milling	8 mm	4 inches

* Industry standard **units**

The forward speed of any milling machine shall be limited to no more than 45 feet/minute.

The teeth on the revolving cutting drum must be continually maintained and shall be replaced as warranted to provide a uniform pavement texture, as outlined in 4.09.03-C, Surface Tolerance.

3. Protection: Protection shall be provided around **visible** existing catch basin inlets, manholes, utility valve boxes, and any similar structures. Any damage to such structures as a result of the milling operation is the Contractor's responsibility and shall be repaired at the Contractor's expense.

To prevent the infiltration of milled material into the storm drainage system, the Contractor shall take special care to prevent the milled material from falling into the inlet openings or inlet grates. Any milled material that falls into inlet openings or inlet grates shall be removed at the Contractor's expense.

B. Removal of Existing Wearing Surface: The bituminous concrete wearing surface, membrane waterproofing and bond breaker shall be removed from the structure(s) using means acceptable to the Engineer to completely expose the concrete bridge deck(s).

Prior to removal of bituminous concrete wearing surface, the Contractor shall field verify the depth of the existing bituminous concrete by obtaining depth measurements (maximum 4 inch diameter holes) at intervals no greater than 25 feet apart in each lane. Depth verification holes shall be filled with bituminous material **and compacted** if the removal of wearing surface operation will not be completed within 5 days.

The existing bituminous concrete wearing surface and membrane waterproofing shall be removed in their entireties to the limits shown on the plans. The removal operations shall not begin until the Contractor is prepared to perform the permanent patching or repair to the underlying concrete within 5 working days. If this is in conflict with "Prosecution and Progress," "Maintenance and Protection of Traffic," or other Contract requirements, the more stringent specification shall apply.

Methods for removal of existing wearing surfaces **shall be** fine milling and shall include as many passes or amount of effort required to completely expose the concrete deck(s). Any membrane not completely removed by the milling process shall be removed by scarifying or other means as approved by the Engineer.

Alternate methods for the removal of a bituminous concrete surface may be submitted to the Engineer for review. Demonstration of the alternate removal methods may be required prior to consideration.

The existing bituminous concrete wearing surface, membrane waterproofing, bond breaker, and any other products being removed shall be disposed of offsite by the Contractor unless otherwise noted in the Contract or as directed by the Engineer.

If membrane waterproofing, as specified elsewhere in the Contract, is to be re-installed on the existing deck(s), the surface profile following removal shall be suitable for such reinstallation. The profile of the cleaned concrete surface shall meet the membrane waterproofing manufacturer's recommendations, and have no gouges greater than 1/2 inch in depth. Any deficiencies that could, in the Engineer's opinion, cause failure of, or puncture the new membrane shall be removed as part of this work.

C. Surface Tolerance:

1. General: The surface shall be free from gouges, longitudinal grooves and ridges, oil film, and other imperfections, that are a result of defective equipment, improper use of equipment, poor workmanship, or inadequate field verification. Any unsatisfactory surfaces caused by the removal operations are the Contractor's responsibility and shall be corrected at the Contractor's expense and to the satisfaction of the Engineer prior to opening the surface to traffic.

Any raised structures shall be delineated with traffic control devices, as directed by the Engineer.

2. Tolerances: All milling types shall provide a satisfactory riding surface with a uniform textured appearance. The Contractor shall perform random spot-checks at a minimum of 5 locations per working shift with a Contractor-supplied 10 foot straight edge to verify the surface tolerances listed below. Random spot-checks (minimum of 5 checks per shift) shall occur at a maximum of 250 feet per pass of the milling machine and shall be performed with the Engineer present. The following tolerances shall apply:

(a) **Coarse Milling:** The variation of the top of two ridges from the testing edge of the straightedge, between any two ridge contact points, shall not exceed 3/8 inch. The variation of the top of any ridge to the bottom of the groove adjacent to that ridge shall not exceed 3/8 inch.

(b) **Fine Milling:** The variation of the top of two ridges from the testing edge of the straightedge, between any two ridge contact points, shall not exceed 1/4 inch. The variation of the top of any ridge to the bottom of the groove adjacent to that ridge shall not exceed 1/4 inch.

Where a surface delamination between bituminous concrete layers or a surface delamination of bituminous concrete on Portland cement concrete causes a non-uniform texture to occur, the depth of milling shall be adjusted in small increments to a maximum of +/- 1/2 inch to eliminate the condition. When removing bituminous concrete pavement entirely from an underlying Portland cement concrete pavement, all bituminous concrete pavement shall be removed leaving a uniform surface of Portland cement concrete, unless otherwise directed by the Engineer.

Any unsatisfactory surfaces produced by the milling operation are the Contractor's responsibility and shall be corrected at the Contractor's expense and to the satisfaction of the Engineer.

D. Transitions:

1. Construction Joints: No transverse vertical face shall be left exposed to traffic. No longitudinal vertical face greater than 1 inch shall be left exposed to traffic. Any other vertical face created by milling shall have a bituminous concrete taper constructed to the temporary transition requirements as described below.

2. Roadway Structures: Roadway structures shall not have a vertical face of greater than 1 inch exposed to traffic as a result of milling. All roadway structure edges and bituminous concrete tapers shall be clearly marked with fluorescent paint. The paint shall be maintained throughout the exposure to traffic.

All structures within the roadway that are exposed to traffic and greater than 1 inch above the milled surface shall receive a transition meeting the following requirements:

- (a) For roadways with a posted speed limit of 35 mph or less:
 - (i) Round structures with an exposed vertical face between 1 inch and 2.5 inches shall be transitioned with a hard rubber tapered protection ring designed for that purpose of the appropriate inside diameter designed specifically to protect roadway structures. Bituminous concrete tapers at a minimum 12 to 1 (12:1) taper in all directions may be substituted for the protection rings if approved by the Engineer.
 - (ii) Round structures with an exposed vertical face greater than 2.5 inches shall receive a transition of bituminous concrete formed at a minimum 12 to 1 (12:1) taper in all directions.
 - (iii) All rectangular structures shall receive a transition of bituminous concrete formed at a minimum 12 to 1 (12:1) taper in all directions.
- (b) For roadways with a posted speed limit of 40, 45 or 50 mph: All structures shall receive a transition of bituminous concrete formed at a minimum 24 to 1 (24:1) taper in all directions of travel. Direction of travel shall include both the leading and trailing sides of a structure. The minimum taper shall be 12 to 1 (12:1) in all other directions.
- (c) For roadways with a posted speed limit of greater than 50 mph: All structures shall receive a transition of bituminous concrete formed at a minimum 36 to 1 (36:1) taper in the direction of travel. Direction of travel shall include both the leading and trailing sides of a structure. The minimum taper shall be 12 to 1 (12:1) in all other directions.

3. Temporary Transitions: If any vertical face is formed in an area exposed to traffic, a temporary paved transition shall be established according to the requirements shown on the plans or in accordance with 4.06.03-5, "**Transitions for Roadway Surface.**" If a milling machine is used to form a temporary transition, the length of the temporary transition shall be in accordance with 4.06.03-5, the requirements shown on the plans, or shall be as directed by the Engineer. A clean vertical face shall be established by saw cutting at all final termini limits of the Project.

4. Milling for Permanent Pavement Transitions: When called for on the plans, milling a tapered "keyway" to transition the top course of a bituminous concrete overlay to an existing

pavement shall be performed as specified elsewhere in the Contract.

E. Sweeping: Prior to opening an area which has been milled to traffic, the pavement shall be thoroughly swept with a sweeper truck. The sweeper truck shall be equipped with a water tank and be capable of removing the millings and loose debris from the surface. The sweeper truck shall operate at a speed that allows for the maximum pickup of millings from the roadway surface. Other sweeping equipment may be provided in lieu of the sweeper where acceptable by the Engineer.

Any milled area that will not be exposed to live traffic for a minimum of 48 hours prior to paving shall require a vacuum sweeper truck in addition to, or in lieu of, mechanical sweeping. The vacuum sweeper truck shall have sufficient power and capacity to completely remove all millings from the roadway surface including any fine particles within the texture of the milled surface. Vacuum sweeper truck hose attachments shall be used to clean around pavement structures or areas that cannot be reached effectively by the main vacuum. Compressed air may be used in lieu of vacuum attachments if approved by the Engineer.

4.09.04—Method of Measurement:

Milling of bituminous concrete will be measured for payment by the number of square yards of area from which the particular type of milling has been completed and the work accepted. Deductions will not be made for minor unmilled areas such as catch basin inlets, manholes, utility boxes and any similar structures.

The removal of wearing surface will be measured for payment by the number of square yards of bituminous concrete wearing surface removed to expose the underlying concrete deck(s). No area deductions will be made for scuppers, joints, and any similar areas.

There will be no measurement for marking roadway structures, transitions for roadway structures and sweeping of any surface that has been milled.

4.09.05—Basis of Payment: Milling work will be paid for at the Contract unit price per square yard for “Fine Milling of Bituminous Concrete (0” to 4”),” “Coarse Milling of Bituminous Concrete (Greater Than 4” Up To 8”),” and “Coarse Milling of Bituminous Concrete (Greater Than 8”).” This price shall include all equipment, tools, labor, and materials incidental thereto. **No additional payments will be made for multiple passes with the milling machine(s).**

Work for the removal of wearing surface will be paid for at the Contract unit price per square yard for “Removal of Existing Wearing Surface,” complete and accepted, which price shall include the field verification, removal of wearing surface, removal of membrane waterproofing and bond breaker, saw cutting, and all equipment, tools and labor. No additional payments will be made for multiple passes with the milling machine(s) to remove the wearing surface.

No separate payments will be made for cleaning the pavement prior to paving; providing protection and doing handwork to remove bituminous concrete around catch basin inlets, bridge scuppers, manholes, utility valve boxes, median barriers, parapets, joints and any similar structures; repairing surface defects as a result of Contractor negligence; providing protection to underground utilities from the vibration of the milling operation; removal of any temporary milled transition; removal and disposal of millings; sweeping and all associated work.

Milling for Pavement Transitions, where identified on the plans, will be paid under a separate item specified elsewhere.

Installation of traffic control devices shall be included under the costs for “Maintenance and Protection of Traffic,” payment for the devices will be under the applicable items.

Pay Item	Pay Unit
Fine Milling of Bituminous Concrete (0” to 4”)	s.y.
Coarse Milling of Bituminous Concrete (Greater Than 4” Up To 8”)	s.y.
Coarse Milling of Bituminous Concrete (Greater Than 8”)	s.y.
Removal of Existing Wearing Surface	s.y.

**SECTION 5.14
PRESTRESSED CONCRETE MEMBERS**

Replace Section 5.14 in its entirety with the following:

**SECTION 5.14
PREFABRICATED CONCRETE STRUCTURAL COMPONENTS**

5.14.01—Description**5.14.02—Materials****5.14.03—Construction Methods**

1. **Submittals**
 - A. **Quality Control Plan**
 - B. **Shop Drawings**
 - C. **Working Drawings**
 - D. **Quality Control Sampling and Testing**
 - E. **Quality Assurance**
 - F. **Assembly Schedule**
2. **Placing Concrete**
3. **Finishing**
4. **Penetrating Sealer Protective Compound**
5. **Marking**
6. **Fabricated Steel Inspection**
7. **Damage**
8. **Additional Requirements for Prestressed Components**
 - A. **Tolerances**
 - B. **Finishing**
 - C. **Joining Deck Units**

5.14.04—Method of Measurement**5.14.05—Basis of Payment**

5.14.01—Description: Work under this item shall consist of furnishing and placing structural components such as precast or prestressed beams, deck units, platforms, foundations, frames, arches, and wingwalls, of the type and size shown on the plans, and all necessary materials and equipment to complete the work.

A Quality Control Plan is required from the fabricator of the precast components.

A detailed Assembly Schedule may be required from the Contractor if noted on the plans.

Dry fit of adjacent components at the precast facility may be required as noted on the plans.

This Section does not apply to standard precast concrete drainage components such as catch basins, manholes or drop inlets as these are covered in Section 5.86 (PC-1 Items).

5.14.02—Materials: All materials shall meet the requirements of M.14.01.

5.14.03—Construction Methods:**1. Submittals:**

A. Quality Control Plan. Facilities producing prefabricated concrete structural components shall have a Quality Control (QC) plan appropriate for the work on file with the Department's Division of Materials Testing. The plan shall include detailed information regarding the personnel and procedures in place to monitor the quality of the work and materials on a daily basis. The plan shall be implemented to the satisfaction of the Contractor and the Engineer.

For work consisting of plainly-reinforced precast components, Certification by the National Precast Concrete Association (NPCA) will be considered but may not relieve the requirement for submittal of a facility-specific Quality Control Plan to the Department.

For work consisting of prestressed components, Certification by the Precast/Prestressed Concrete Institute (PCI) will be considered but may not relieve the requirement for submittal of a facility-specific Quality Control Plan to the Department.

- B. Shop Drawings.** Before fabrication, the Contractor shall submit Shop Drawings to the Engineer for acceptance in accordance with 1.05.02-3.
- C. Working Drawings:** Prior to installation of the precast components, the Contractor shall submit Working Drawings and supporting computations for the lifting and placement of the components in their final position in accordance with 1.05.02-2. The Contractor shall be solely responsible for the **adequacy** of the drawings and computations, falsework, and other equipment and material necessary to place the components safely and without damage to the components.
The Contractor's responsibility includes the investigation of stresses incurred within the components during placement.
- D. Quality Control Sampling and Testing.** A schedule for making and testing concrete cylinders from the material used in the casting of each prefabricated concrete component must be included in the QC plan. The cylinders must be cured by the same methods employed for the curing of the component. Results shall be used to verify when 28-day strength requirements have been met, and if applicable, when strength required for transfer of the prestressing load is achieved.
When requested by the Engineer, concrete mix documentation shall be made available for each component cast. The information contained within the documentation shall include the following:
Batching Date and time of day
Batch ID
Load size
Project number
W/C ratio
Batch Quantities and sources
Fine aggregate
Coarse aggregate
Water
Admixtures
Type of and source of cement
- E. Quality Assurance:** Quality assurance is the prerogative of the Engineer. The Department shall be provided a separate office within the production facility having an area of at least 80 square feet, with the least dimension to be 6 feet. This office shall be maintained at a minimum temperature of 65°F. It shall be clean and provided with a desk and chair and shall be free of extraneous material and equipment. Sufficient light and ventilation shall be provided. During the summer months, the office temperature shall not exceed the ambient air temperature outside the facility.
- F. Assembly Schedule:** When noted in the Contract, the Contractor shall submit a detailed schedule for the installation of the components that includes cast dates, shipping dates, project-site delivery dates for each component when required. The schedule must account for any time required for proper curing of cast-in-place closure pours or other elements. The schedule shall be revised as needed and approved by the Engineer prior to the initiation of any road closure.
- 2. Placing Concrete:** The Contractor shall provide the Engineer advance notification prior to placement, in accordance with 1.05.10. Concrete may be deposited in the forms after the Contractor or its representative has inspected the condition and adequacy of the forms, location of the prestressing elements, reinforcing steel, and all other embedded components.
The concrete temperature shall be 60°F to 90°F at the time of placement. The use of truck-mixed or ready-mixed concrete from a source not located at the precast facility is prohibited.
Unless otherwise specified on the plans, concrete cover shall be a minimum of 1 1/2 inches and must be maintained for prestressing strands by the use of approved spreaders or by bundling in areas adjacent to openings, cavities, or inserts. Unless otherwise specified, stirrups and ties shall have a minimum cover of 1 inch at these locations. All internal components shall remain in their correct position during concrete placement and vibration.
Interruption in the placement of the concrete resulting in the creation of a cold joint will be cause for rejection. Concrete shall be vibrated sufficiently to produce a surface free from imperfections such as honeycombing, segregation, cracking, or checking. Any deficiencies noted in the components (internal or on the surfaces) may also be cause for rejection.

3. **Finishing:** All fins, runs, or mortar shall be removed from the concrete surfaces which will remain exposed. Form marks on exposed surfaces shall be smoothed by grinding.
4. **Penetrating Sealer Protective Compound:** Concrete surfaces shall be prepared as specified in the Contract. The sealer shall be applied in accordance with the accepted application procedures at the rate specified by the manufacturer, and as described elsewhere in the Contract.
5. **Marking:** Precast Elements shall be identified as to Project, structure, casting date, and position in the structure by means of a non-corrosive tag embedded permanently or stenciled at a visible location on the piece mark end.
6. **Fabricated Steel Inspection:** The provisions of 6.03.03-4 (Shop Fabrication), (a) Notification, shall apply to the steel items, and the pertinent requirements contained therein shall apply equally to the work performed at the facility producing the precast concrete products.
7. **Damage:** Components damaged at any time by improper handling, storing, transporting, or erecting shall be repaired to the satisfaction of the Engineer by the Contractor at its expense.
8. **Additional Requirements for Prestressed Components**

- A. **Tolerances:** The dimensional tolerance(s) of prestressed components shall be as specified in the PCI "Manual for Quality Control for Plants and the Production of Structural Precast Concrete Products" (MNL116 Latest Edition), unless otherwise specified.
- B. **Finishing:** Prestressing elements such as strands shall be recessed 1 inch (unless noted otherwise on the plans), and form ties, inserts and lifters shall be recessed 1/4 to 1/2 inch into the component. The recess shall be patched with an approved material. After curing, the patch shall be coated with an approved sealer. Surfaces including projection steel shall not be coated. Additional finishing of component surfaces may be shown on the plans.
- C. **Joining Deck Units:** Transverse tie strands shall be post tensioned to the total force shown on the plans. When the length of the strand is greater than 13 feet, the Contractor shall verify the tensioning force after 36 hours and the strand shall be re-tensioned if necessary. After verification, the longitudinal shear keys between the adjacent deck units and the recesses shall be thoroughly cleaned and wetted prior to the placement of the non-shrink grout.

If premixed non-shrink grout is used the key areas shall be prepared, and the grout mixed and placed as recommended by the grout manufacturer. Where the top surfaces of the adjacent deck units do not match, grout may be used to form a smooth transition to the satisfaction of the Engineer.

No superimposed dead or live loads shall be applied to the adjacent components until the non-shrink grout in the longitudinal shear keys and recesses has cured sufficiently to prevent any independent movement of a component or cracking of the grout.

5.14.04—Method of Measurement:

1. **Prestressed Beam (Type):** Prestressed Beam (Type) will be measured for payment by the number of linear feet installed and accepted in accordance with the pay limits shown on the plans.
2. **Prestressed Deck Units (Size):** Prestressed Deck Units will be measured for payment by the number of linear feet installed and accepted of the size and at the location indicated on the plans.
3. **Prestressed Approach Slab:** Prestressed Approach Slab will be measured for payment by the number of square yards as shown on the plans.
4. **Precast Concrete Walls:** Precast Concrete Walls will be measured for payment by the number of cubic yards installed as shown on the plans.
5. **Precast Substructure Element (Type):** Precast Substructure Elements (Type) will be measured for payment by the number of cubic yards installed at the location indicated on the plans.
6. **Precast Concrete Three-Sided Rigid Frame:** Precast Concrete Three-Sided Rigid Frame will be measured for payment by the number of linear feet installed as shown on the plans.

5.14.05—Basis of Payment:

1. **Prestressed Beam (Type):** This work will be paid for at the Contract unit price per linear foot for "Prestressed Beam (Type)" complete in place, including all materials, equipment and tools and labor incidental thereto.

- 2. **Prestressed Deck Units (Size):** This work will be paid for at the Contract unit price per linear foot for the size indicated on the plans for “Prestressed Deck Units” complete in place, including all materials, equipment and tools and labor incidental thereto.
- 3. **Prestressed Approach Slab:** This work will be paid for at the Contract unit price per square yard for “Prestressed Approach Slab” complete in place, including all materials, equipment and tools and labor incidental thereto.
- 4. **Precast Concrete Walls:** This work will be paid for at the Contract unit price per cubic yard for “Precast Concrete Walls” complete in place, including all materials, equipment and tools and labor incidental thereto.
- 5. **Precast Substructure Element (Type):** This work will be paid for at the Contract unit price per cubic yard for “Precast Substructure Element (Type)” complete in place, including all materials, equipment and tools and labor incidental thereto.
- 6. **Precast Concrete Three-Sided Rigid Frame:** This work will be paid for at the Contract unit price per linear foot for “Precast Concrete Three-Sided Rigid Frame” complete in place, including all materials, equipment and tools and labor incidental thereto.

Penetrating sealer will be paid separately under the Contract item for Penetrating Sealer Protective Compound.

Pay Item	Pay Unit
Prestressed Beam (Type)	l.f.
Prestressed Deck Units (Size)	l.f.
Precast Approach Slab	s.y.
Precast Concrete Walls	c.y.
Precast Substructure Element (Type)	c.y.
Precast Concrete Three-Sided Rigid Frame	l.f.

**SECTION 6.01
CONCRETE FOR STRUCTURES**

Replace Section 6.01 in its entirety with the following:

**SECTION 6.01
CONCRETE FOR STRUCTURES**

6.01.01—Description

6.01.02—Materials

6.01.03—Construction Methods

I. Contractor Quality Control (QC) Requirements for Bridge Deck and Parapet Construction

1. General
2. Contractor Organization
3. Concrete Mix Design
4. Transportation and Delivery of Concrete
5. Placement and Finishing of Concrete
6. Curing of Concrete
7. Contractor QC testing
8. Quality Control Manager (QCM)
9. Pre-Placement Meeting
10. Submission
11. Test Results/CQCP Changes

II. Requirements for New Construction

1. Falsework and Forms
2. Protection from Environmental Conditions
3. Transportation and Delivery of Concrete
4. Acceptance Testing and Specimens
5. Progression Cylinders and Compressive Strength Specimens
6. Handling and Placing Concrete
7. Finishing Plastic Concrete
8. Bearing Surfaces
9. Curing Concrete
10. Finishing Concrete Surfaces
11. Mortar, Grout, Epoxy and Joint Seal
12. Application of Loads
13. Dispute Resolution

III. Additional Requirements for Surface Repairs and Structural Repairs

1. Work Area Access and Shielding
2. Concrete Removal
3. Surface Preparation
4. Installation of Embedded Galvanic Anodes
5. Welded Wire Fabric in Vertical and Overhead Surface Repairs
6. Formwork
7. Concrete Placement and Curing
8. Form Removal and Sequence of Repair
9. Finishing
10. Sounding of Completed Repairs
11. Sealing Concrete Surfaces

6.01.04—Method of Measurement

1. Concrete used for New Construction
2. Underwater Concrete
3. Concrete used for Surface or Structural Repairs
4. Joint Filler
5. Closed Cell Elastomer

6.01.05—Basis of Payment

1. Concrete
2. Underwater Concrete
3. Concrete Used for Structural Steel Repairs or Surface Repairs
4. Joint Filler
5. Closed Cell Elastomer

6.01.01—Description: This item shall include cast-in-place (CIP) concrete for use in new construction, surface repair or structural repair of bridges and culverts, walls, catch basins, drop inlets and other incidental construction. The concrete shall be composed of Portland cement, pozzolans, fine and coarse aggregate, admixtures and water, prepared and constructed in accordance with these specifications, at the locations and of the form dimensions and class shown on the plans, or as directed by the Engineer.

The use of concrete from dry batch or central mixed plants is permitted for all CIP concrete mixtures.

6.01.02—Materials: The materials for this work shall meet the requirements of M.03. Surface or structural repair concrete shall be documented on the delivery ticket, as required in 6.01.03-II-3(a), as having the plastic properties necessary for confined placement to ensure appropriate workability for consolidation within the forms.

6.01.03—Construction Methods:**I. Concrete Quality Control (QC) Requirements for All Bridge Deck and Bridge Parapet**

Construction: The Contractor must demonstrate to the Engineer that the materials and work that will be provided by their field staff, subcontractors, and suppliers meets Contract specification requirements.

This effort shall be documented with a **Concrete Quality Control Plan (CQCP)** and shall address the communication with all parties, on-site inspection, sampling and testing frequency necessary to keep the production, placement and finishing operations in control, to determine when an operation has gone out of control and anticipated procedure to correct the situation in a timely manner.

1. General – provide an overview of the means and methods anticipated to perform the work including any anticipated conditions that may need additional attention (such as seasonal conditions requiring heating or cooling of concrete)
2. Contractor Organization – address authority levels/duties by position and name of persons holding those positions; include those who have decision making authority with regard to quality control, materials, sampling and testing who can be contacted by the Engineer
3. Concrete Mix Design – identify concrete supplier(s); provide copies of all applicable mix designs to field staff; and address submittal timeframe
4. Transportation and Delivery of Concrete – identify the supplier’s plant capacity and ability to ensure continuous delivery to the Project to meet the requirements of the mix design and a corrective procedure if it does not meet Project requirements; include a provision for the addition of admixtures and follow up testing
5. Placement and Finishing of Concrete – identify and describe:
 - (a) placement equipment
 - (b) placement method(s) to be used (chute, pump, hopper or other)
 - (c) starting point and direction of placement (logistical sequencing)
 - (d) slip forming, formwork, stay-in-place forms or other forming method(s)
 - (e) joint construction method(s)
 - (f) process and documentation that the elevations, base, forms, reinforcement (including support chairs and ties), utility inserts or any other appurtenance installations have been inspected by the Contractor prior to concrete placement
 - (g) equipment and method(s) to be used for vibrating and consolidating concrete
 - (h) procedure for verifying adequate consolidation and how segregation will be addressed
 - (i) schedule and method(s) to be used for finishing all exposed surfaces
6. Curing of Concrete – describe schedule and method(s) for curing of concrete and how the method(s) will be monitored and maintained
7. Contractor QC testing – identify person(s) or firms responsible for Contractor QC testing and provide copies of their certification(s) (see 6.01.03-II-5), and testing facility location(s). In addition, describe the process used for communication between the QC testing personnel and the Contractor project staff; describe what measures will be taken when test results are out of compliance; this shall include what

increased frequency of testing is to be performed to verify that concrete properties are in compliance; the threshold at which time placement ceases; describe what protective measures will be used in case of unforeseen weather

8. The CQCP shall include the name and qualifications of a Quality Control Manager (QCM) provided by the Contractor. The QCM shall be responsible for the administration of the CQCP, and any modifications that may become necessary. The QCM shall have the ability to direct all Contractor personnel on the Project during concreting operations and must communicate directly with the concrete supplier. The QCM shall be certified as either a **Concrete Transportation Construction Inspector by the American Concrete Institute (ACI)** or a **NETTCP Concrete Inspector**.

9. The CQCP must include a provision for pre-placement meeting(s) to be held with representatives of the Engineer, the concrete supplier, the QCM and the Contractor's field staff supervising the work.

- (a) Timing and number of the meeting(s) will be determined by the complexity of the mix design or placement.
- (b) Non-Standard mix designs that require trial placements will be discussed at the Preconstruction Meeting to remind the Contractor of the time needed for testing. Additional meeting(s) should be scheduled at least 90 days prior to first use of non-standard mix designs, to allow suppliers to perform trial batches and testing.
- (c) Discussions shall include the configuration and specific application that the concrete will be used for, plastic properties and workability, any mix design challenges, trial placement procedures and subsequent trial results, timing and quantities. Refer to 6.01.03-II-6(e) for additional requirements.

10. The CQCP shall be submitted to the Engineer and concrete supplier for review and comment a minimum of 30 days prior to production or placement. Production and placement shall not occur until all comments of the Engineer and supplier have been addressed by the Contractor. Changes to the CQCP based on data not available at time of submittal may be added via addendum.

11. The Contractor shall provide the Engineer QC test results within 48 hours after testing or inspection in a format acceptable to the Engineer. The Contractor shall also maintain complete records of all QC tests.

Review of the CQCP does not relieve the Contractor of its responsibility to comply with the Project specifications. The Contractor may modify the CQCP as work progresses and must document the changes in writing prior to resuming operations. These changes include but are not limited to changes in quality control procedures or personnel.

II. Requirements for New Construction:

1. Falsework and Forms: Falsework is considered to be any temporary structure which supports structural elements of concrete, steel, masonry or other material during the construction or erection. Forms are to be considered to be the enclosures or panels which contain the fluid concrete and withstand the forces due to its placement and consolidation. Forms may in turn be supported on falsework.

This work shall consist of the construction and removal of falsework and forms that are designed by the Contractor in the execution of the work, and whose failure to perform properly could adversely affect the character of the Contract work or endanger the safety of adjacent facilities, property, or the public. Forms shall be mortar tight. Forms and falsework shall be of sufficient rigidity and strength to safely support all loads imposed and to produce in the finished structure the lines and grades indicated in the Contract documents. Forms shall also impart the required surface texture and rustication and shall not detract from the uniformity of color of the formed surfaces. Forms shall be made of wood, steel or other material approved by the Engineer.

- (a) **Design:** The design of falsework and formwork shall conform to the *AASHTO Guide Design Specifications for Bridge Temporary Works*, or to other established and generally accepted design codes such as ACI Standard *ACI 347-Recommended Practice for Concrete Formwork* or specific form or falsework manufacturer specifications. When other than new or undamaged materials are used, appropriate reductions in allowable stresses, and decreases in resistance factors or imposed loads shall be used for design.
- (b) **Loads:** The design of the falsework and forms shall be based on load factors specified in the *AASHTO LRFD Bridge Design Specifications* and all applicable load combinations shall be investigated. The design load for falsework shall consist of the sum of appropriate dead and live vertical loads and any horizontal loads. As a minimum, dead loads shall include the weight of the

falsework and all construction material to be supported. The combined unit weight of concrete, reinforcing and pre-stressing steel, and forms that is supported shall be assumed to be not less than:

1. Normal-weight concrete: 0.16 kip/ft³
2. Lightweight concrete: 0.13 kip/ft³

Live loads shall consist of the actual weight of any equipment to be supported, applied as concentrated loads at the points of contact and a uniform load of not less than 0.02 kip/ft² applied over the area supported, plus 0.075 kip/ft applied at the outside edge of deck overhangs.

The horizontal load used for the design of the falsework bracing system shall be the sum of the horizontal loads due to equipment; construction sequence including unbalanced hydrostatic forces from fluid concrete and traffic control devices; stream flow, when applicable; and an allowance for wind. However, in no case shall the horizontal load to be resisted in any direction be less than 2% of the total dead load.

For post-tensioned structures, the falsework shall also be designed to support any increase in or redistribution of loads caused by tensioning of the structure. Loads imposed by falsework onto existing, new, or partially completed structures shall not exceed those permitted in 6.01.03-II-12, Application of Loads.

- (c) **Working Drawings:** The working drawings for falsework and formwork shall be prepared in accordance with 1.05.02 whenever the falsework or formwork exceeds 14.0 feet high or whenever vehicular, marine, or pedestrian traffic may travel under or adjacent to the falsework or formwork. Working drawings shall include the sequence, method and rate of placement of the concrete.

Manufacturer catalog cuts or written installation procedures shall be provided for any clips, braces, hangers or other manufactured parts used with the formwork or falsework.

- (d) **Construction:** Forms and falsework shall be built true to lines and grades shall be strong, stable, firm, mortar-tight and adequately braced or tied, or both. They shall be designed and constructed to withstand all loads and pressures including those imposed by plastic concrete, taking full account of the stresses due to the rate of placement, effect of vibration and conditions brought about by construction methods. Forms and falsework shall be constructed to compensate for variations in camber of supporting members and allow for deflections.

Falsework and formwork shall be chamfered at all sharp corners, unless otherwise ordered or permitted, and shall be given a slight bevel or draft in the case of projections to ensure satisfactory removal. Materials for falsework and formwork and their supports, ties and bracing, shall be of the type, quality and strength to achieve the structural requirements. Form material in contact with concrete shall provide the finished concrete surface smoothness as specified in 6.01.03-II-10, Finishing Concrete Surfaces, and shall have a uniform appearance.

Falsework and formwork shall be treated with form oil or other release agent approved by the Engineer before the reinforcing steel is placed or self-releasing forms approved by the Engineer may be used. Release agents which will adhere to or discolor the concrete shall not be used.

Falsework and formwork for concrete surfaces exposed to view shall produce a smooth surface of uniform texture, free of voids, indentations, protrusions and bulges. Panels lining falsework and formwork shall be arranged so that the joint lines form a symmetrical pattern conforming to the general lines of the structure. The same type of form-lining material shall be used throughout each element of a structure. Falsework and formwork shall be sufficiently rigid so that the undulation of the concrete surface shall not exceed 1/4 inch when checked with a 4 foot straightedge or template.

For non-exposed surfaces the falsework and formwork shall be sufficiently rigid so that the undulation of the concrete surface shall not exceed 1/2 inch when checked with a 4 foot straightedge or template.

Metal ties and anchors to hold the falsework and formwork in alignment and location shall be so constructed that the metal work can be removed to a depth of at least 2 inches from the concrete surface without damage to the concrete. All cavities resulting from the removal of metal ties shall be filled after removal of forms with cement mortar of the same proportions used in the body of the work or other materials approved by the Engineer, and the surface finished smooth and even, and if exposed in the finished work, shall be similar in texture and color of adjacent surfaces. With permission of the Engineer, the Contractor need not remove from the underneath side of bridge decks portions of metal devices used to support reinforcing steel providing such devices are of material, or are adequately coated with material, that will not rust or corrode. When coated

reinforcing steel is required, all metal ties, anchorages, or spreaders that remain in the concrete shall be of corrosion-resistant material or coated with a dielectric material.

Forms shall be clean and clear of all debris. For narrow walls and columns where the bottom of the form is inaccessible, an access opening will be allowed in the form and falsework for cleaning out extraneous material.

(e) **Vacant**

- (f) **Bridge Decks:** After erection of beams and prior to placing falsework and forms, the Contractor shall take elevations along the top of the beam at the points shown on the plans or as directed by the Engineer. The Contractor shall calculate the haunch depths and provide them to the Engineer a minimum of 7 days prior to installing the falsework and forms. The Contractor shall also provide calculations for the setting of the overhang brackets based on the final beam deflection. These calculations shall be based on the final proposed deck grade and parapet elevations.

Falsework or formwork for deck forms on girder bridges shall be supported directly on the girders so that there will be no appreciable differential settlement during placing of the concrete. Girders shall be either braced and tied to resist any forces that would cause rotation or torsion in the girders caused by the placing of concrete for diaphragms or decks, or shown to be adequate for those effects. Unless specifically permitted, welding of falsework support brackets or braces to structural steel members or reinforcing steel shall not be allowed.

- (g) **Stay-In-Place Metal Forms for Bridge Decks:** These forms may be used if shown in the Contract documents or approved by the Engineer. Prior to the use of such forms and before fabricating any material, the Contractor shall submit working drawings to the Engineer for review in accordance with 1.05.02. These drawings shall include the proposed method of form construction, erection plans including placement plans, attachment details, weld procedure(s), material lists, material designation, gage of all materials, and the details of corrugation. Also, copies of the form design computations shall be submitted with the working drawings. Any changes necessary to accommodate stay-in-place forms, if approved, shall be at no cost to the Department.

The metal forms shall be designed on the basis of the dead load of the form, reinforcement and the plastic concrete, including the additional weight of concrete [considered to be equivalent to the weight imposed by an additional concrete thickness equal to 3% of the proposed deck thickness, but not to exceed 0.3 inch] due to the deflection of the metal forms, plus 50 psf for construction loads. The allowable stress in the corrugated form and the accessories shall not be greater than 0.725 times the yield strength of the furnished material and the allowable stress shall not exceed 36,000 psi. The span for design and deflection shall be the clear distance between edges of the beams or girders less 2 inches and shall be measured parallel to the form flutes. The maximum deflection under the weight of plastic concrete, reinforcement, and forms shall not exceed 1/180 of the form span or 0.5 inches, whichever is less. In no case shall the loading used to estimate this deflection be less than 120 psf. The permissible form camber shall be based on the actual dead load condition. Camber shall not be used to compensate for deflection in excess of the foregoing limits. The form support angles shall be designed as a cantilever and the horizontal leg of the form support angle shall not be greater than 3 inches.

No stay-in-place metal forms shall be placed over or be directly supported by the top flanges of beams or girders. The form supporting steel angles may be supported by or attached to the top flanges.

Stay-in-place metal forms shall not be used in bays where longitudinal slab construction joints are located, under cantilevered slabs such as the overhang outside of fascia members, and bridges where the clearance over a salt-laden body of water is less than 15 feet above mean high water level.

Welding to the top flanges of steel beams and girders is not permitted in the areas where the top flanges are in tension, or as indicated on the plans. Alternate installation procedures shall be submitted addressing this condition.

Drilling of holes in pre-stressed concrete beams or the use of power-actuated tools on the prestressed concrete beams for fastening of the form supports to the pre-stressed concrete beams will not be permitted. Welding of the reinforcing steel to the pre-stressed units is not permitted.

All edges of openings cut for drains, pipes, and similar appurtenances shall be independently supported around the entire periphery of the opening. All fabricated stay-in-place metal forms shall be unloaded, stored at the Project Site at least 4 inches above the ground on platforms, skids or other suitable supports and shall be protected against corrosion and damage and handled in such a manner

as to preclude damage to the forms. Damaged material shall be replaced at no additional cost to the State.

Any exposed form or form support metal where the galvanized coating has been damaged, shall be thoroughly cleaned, wire brushed, then coated with 2 coats of Zinc Dust – Zinc Oxide primer, MIL-DTL-24441 or another product acceptable to the Engineer.

The forms shall be installed from the topside in accordance with the manufacturer's recommended installation procedures. The form supports shall ensure that the forms retain their correct dimensions and positions during use at all times. Form supports shall provide vertical adjustment to maintain design slab thickness at the crest of corrugation, to compensate for variations in camber of beams and girders and to allow for deflections. Stay-in-place metal forms shall have a minimum depth of the form valley equal to 2 inches. The forms shall have closed tapered ends. Lightweight filler material shall be used in the form valleys.

All field cutting shall be done with a steel cutting saw or shears including the cutting of supports, closures and cutouts. Flame cutting of forms is not permitted.

All welding shall be performed by Department-certified welders in accordance with 1.05.17, **Welding**. Welding of forms to supports is not permitted.

The steel form supports shall be placed in direct contact with the flange of stringer or floor beam flanges and attached by bolts, clips, welding where permitted, or other approved means. Form sheets shall not be permitted to rest directly on the top of the stringer or floor beam flanges. The forms shall be securely fastened to form supports with self-drilling fasteners and shall have a minimum bearing length of 1 inch at each end. In the areas where the form sheets lap, the form sheets shall be securely fastened to one another by fasteners at a maximum spacing of 18 inches. The ends of the form sheets shall be securely attached to the support angles with fasteners at a maximum spacing of 18 inches or 2 corrugation widths, whichever is less.

The depth of the concrete slab shall be as shown on the plans and the corrugated forms shall be placed so that the top of the corrugation will coincide with the bottom of the deck slab. No part of the forms or their supports shall protrude into the slab. All reinforcement in the bottom reinforcement mat shall have a minimum concrete cover of 1 inch unless noted otherwise on the plans.

The completed stay-in-place metal form system shall be sufficiently tight to prevent leakage of mortar. Where forms or their installation are unsatisfactory in the judgment of the Engineer, either before or during placement of the concrete, the Contractor shall correct the defects before proceeding with the work.

- (h) **Construction Joints:** Construction joints other than those shown on the plans will not be permitted without prior approval of the Engineer. In joining fresh concrete to concrete that has already set, the work already in place shall have all loose and foreign material removed, and the surface roughened and thoroughly drenched with water.

All reinforcing steel shall extend continuously through joints. Where unplanned construction joints may be needed, they shall be constructed as directed by the Engineer.

- (i) **Expansion and Contraction Joints:** Expansion and contraction joints shall be constructed at the locations and in accordance with the details specified in the Contract. The forming of joint openings shall be dimensioned in accordance with the joint manufacturer's design requirements. Joints include open joints, filled joints, joints sealed with sealants, joints reinforced with steel armor plates or shapes, paraffin coated joints, and joints with combinations of these features.

Open joints shall be placed at locations designated on the plans and shall be formed by the insertion and subsequent removal of templates of wood, metal or other suitable material. The templates shall be so constructed that their removal may be readily accomplished without damage to the work.

Filled joints shall be made with joint filler, the materials for which shall meet the requirements of the plans and of these specifications.

For mechanical joint systems, the concrete shall be placed in such a manner that does not interfere with the movement of the joint.

- (j) **Pipes, Conduits and Utility Installations:** The Contractor shall coordinate the installation of pipes, conduits and utilities as shown on the plans and in accordance with the Contract or as directed by the Engineer. The openings accommodating such pipe, conduit and utility installations shall be incorporated into the formwork by the Contractor.

- (k) **Anchorage:** Anchor bolts and systems shall be set to the requirements of the plans and Contract. Anchor bolts and systems shall be clean and free of dirt, moisture or other foreign materials at the time of installation. The anchor bolts and systems shall be installed prior to placing concrete. With the Engineer’s approval, the Contractor may install anchorages after placement and setting of the concrete or in formed holes. The anchorages shall be installed into drilled or formed holes having a diameter and a depth suitable to receive the bolts in accordance with the grout manufacturer’s requirements. Such holes shall be located to avoid damage to the existing reinforcement. All holes shall be perpendicular to the plane surface. The Contractor shall take every precaution necessary to prevent damage to the concrete due to freezing of water or grout in anchor bolt holes.
- (l) **Ornament or Reverse Moulds:** Ornamental work, when so noted on the plans, shall be formed by the use of reverse moulds. These moulds shall be produced by a qualified manufacturer approved by the Engineer. They shall be built in accordance with the general dimensions and appearance shown on the plans. The Contractor shall submit all detailed drawings, models, or carvings for review by the Engineer before the moulds are made.

The Contractor shall be responsible for their condition at all times, and shall be required to remove and replace any damaged or defective moulds at no additional cost to the State.

The surfaces of the moulds shall be given a coating of form release agent to prevent the adherence of concrete. Any material which will adhere to or discolor the concrete shall not be used.

Form Liners, if required, shall be installed as specified elsewhere.

- (m) **Removal of Falsework and Forms:** The Contractor shall consider the location and character of the structure, the weather, the materials used in the mix, and other conditions influencing the early strength of the concrete when removing forms and falsework. Methods of removal likely to cause damage to the concrete surface shall not be used. Supports shall be removed in such a manner as to permit the structure to uniformly and gradually take the stresses due to its own weight. For structures of 2 or more spans, the sequence of falsework release shall be as specified in the Contract or approved by the Engineer.

Removal shall be controlled by field-cured cylinder tests. The removal shall not begin until the concrete has achieved 75% of the design compressive strength. To facilitate finishing, side forms carrying no load may be removed after 24 hours with the permission of the Engineer, but the curing process must be continued for 7 days.

When the results of field-cured cylinder tests are unavailable, the time periods listed in Table 6.01.03-1, exclusive of days when the temperature drops below 40°F, may govern the removal of forms.

Table 6.01.03-1 Time Restrictions for Removal of Formwork

Structure Element	Minimum Time Period
Arch Centers, centering under beams, pier caps, and unsupported elements	14 days
Slabs on grade, Abutments and Walls	24 hours
Columns	2 days
Bridge Decks	28 days

The Contractor may submit for review and approval by the Engineer, alternate methods to determine the in-place strength of the concrete for removal of forms and falsework.

2. Protection from Environmental Conditions: The concrete shall be protected from damage due to weather or other environmental conditions during placing and curing periods. In-place concrete that has been damaged by weather conditions shall be either repaired to an acceptable condition or removed and replaced as determined by the Engineer.

- (a) **Rain Protection:** The placement of concrete shall not commence or continue unless adequate protection satisfactory to the Engineer is provided by the Contractor.
- (b) **Hot Weather Protection:** When the ambient air temperature is above 90°F, the forms, which will come in contact with the mix shall be cooled to below 90°F for a minimum of 1 hour prior to and 1 hour after completion of the concrete placement by means of a water spray or other methods satisfactory to the Engineer.

- (c) **Cold Weather Protection:** When there is a probability of ambient air temperature below 40°F during placement and curing, a Cold-Weather Concreting Plan shall be submitted to the Engineer for review and comment. The Plan shall detail the methods and equipment, including temperature measuring devices that will be used to ensure that the required concrete and air temperatures are maintained.
1. Placement: The forms, reinforcing steel, steel beam flanges, and other surfaces which will come in contact with the mix shall be heated to a minimum of 40°F, by methods satisfactory to the Engineer, for a minimum of 1 hour prior to, and maintained throughout, concrete placement.
 2. Curing: For the first 6 days, considered the initial cure period, the concrete shall be maintained at a temperature of not less than 45°F and the air temperature surrounding the structure shall be maintained at a temperature of not less than 60°F. When the concrete mix includes pozzolans or slag, the initial cure period shall be increased to 10 days. After the initial cure period, the air surrounding the structure shall be maintained above 40°F for an additional 8 days. If external heating is employed, the heat shall be applied and withdrawn gradually and uniformly so that no part of the concrete surface is heated to more than 90°F or caused to change temperature by more than 20°F in 8 hours. The Engineer may reduce or increase the amount of time that the structure must be protected or heated based on an indication of in-place concrete strength acceptable to the Engineer.
- (d) **Additional Requirements for Bridge Decks:** Prior to the application of curing materials, all the concrete placed on bridge decks shall be protected from damage due to rapid evaporation by methods acceptable to the Engineer. During periods of low humidity (less than 60% relative humidity), sustained winds of 25 mph or more, or ambient air temperatures greater than 80°F the Contractor shall provide written details of additional measures to be taken during placement and curing.
- Protection may include increasing the humidity of the surrounding air with fog sprayers and employing wind-breaks or sun-shades. Additional actions may include reduction of the temperature of the concrete prior to placement, scheduling placement during the cooler times of days or nights, or any combination of these actions.
- (e) **Concrete Exposed to Salt Water:** No Construction joints shall be formed between the levels of extreme low water and extreme high water or the upper limit of wave action as determined by the Engineer.

3. Transportation and Delivery of Concrete: All material delivered to the Project shall be supplied by a producer qualified in accordance with M.03. The producer shall have sufficient plant capacity and trucks to ensure continuous delivery at the rate required to prevent the formation of cold joints.

- (a) **Material Documentation:** All vendors producing concrete must have their weigh scales and mixing plant automated to provide a detailed **delivery** ticket. Delivery tickets must include the following information:

1. State of Connecticut
2. Name of producer, identification of plant
3. Date and time of day
4. Type of material
5. Cubic yards of material **contained**
6. Project number, purchase order number, name of Contractor (if other than producer)
7. Truck **identification** number
8. **Weights** of individual aggregate, cement, water, and any admixtures
9. Water/cement ratio, and
10. Additional water allowance in gallons

A State inspector may be present to monitor batching or weighing operations.

The Contractor shall notify the Engineer immediately if there is a malfunction of the recording system in the automated plant or weigh scales.

Manually written tickets containing all required information may be allowed for up to 1 hour after malfunction **but must be** signed by an authorized representative of the producer.

- (b) **Transportation of Mixture:** Trucks delivering concrete shall be qualified in accordance with M.03.

If the concrete mix arrives at the Project with a slump lower than **required**, **additional** water may be **added by the concrete producer's quality control staff or representative** as a means to temper the

concrete. This tempering may only be done after the Engineer and Contractor are notified. The quantity of water in gallons added to the concrete cannot exceed the allowance shown on the delivery ticket. The Contractor is responsible for subsequent testing of the concrete to demonstrate suitable workability has been achieved.

The concrete shall be completely discharged into the forms within 1-1/2 hours from the batch time indicated on the delivery ticket. This time may be extended if the measured temperature of the concrete is below 90°F. This time may also be reduced if the temperature of the concrete is over 90° F. Rejected concrete shall be disposed of by the Contractor at no cost to the State.

The addition of chemical admixtures or air entrainment admixtures at the Project Site, to increase the workability or to alter the time of set, will only be permitted if prior approval has been granted by the Engineer. The addition of air entrainment admixtures at the Project Site will only be performed by the producer’s quality control staff or representative. The Contractor is responsible for follow-up quality control testing to verify compliance with the Specifications.

4. Acceptance Testing and Test Specimens: The Contractor shall furnish the facilities and concrete required for sampling, transport to the testing location in the field, performing field testing and for casting sample cylinders for compressive-strength determinations. The Department will furnish personnel for sampling and casting Acceptance specimens and the number of specimens required will be determined by the Engineer. The equipment for the Department’s testing is provided for elsewhere in the Contract.

- (a) **Temperature, Air Content and Slump:** Field testing in accordance with AASHTO T-23, “Making and Curing Concrete Test Specimens in the Field” will be performed at the point of placement and at a frequency determined by the Engineer.
- (b) **Acceptance Testing and Compressive Strength Specimens:** Concrete samples are to be taken at the point of placement into the forms or molds. Representatives of the Engineer will sample the mix.

Table 6.01.03-2 Plastic Properties of Portland Cement Concrete

Standard Mix Class	Air Content	Slump	Concrete Temperature
PCC0334Z ¹ (3300 psi)	6.0 +/- 1.5%	See note 3.	60°-90° F
PCC0336Z ¹ (3300 psi)			
PCC0446Z ¹ (4400 psi)			
PCCXXX8Z ¹	7.5 +/- 1.5%		
Modified Standards ²	6.0 +/- 1.5% ²		
Special Provision Mix ⁴	As specified		
¹ “Z” denotes the Exposure Factor 0, 1, 2, or 3 as described in Table M.03.02-1a			
² Modifications to Standard Mixes, including mixes placed by pumping, shall be reviewed by the Engineer prior to use. These include but are not limited to the use of chemical admixtures such as high range water reducing (HRWR) admixtures and the use of coarse aggregate sizes for that class not specified in M.03.			
³ Slump must be consistent with the workability required for proper placement of the concrete taking into account the minimum concrete cover and design clearances between surfaces or obstructions within the forms.			
⁴ All concrete mixes with a mix design strength not shown in the table must be reviewed by the Engineer on a case-by-case basis. Limits on the plastic properties and strength requirements of these mixes are listed in the Specifications.			

The Contractor shall provide and maintain facilities on the Project Site, acceptable to the Engineer, for sampling, transporting the initial sample, casting, safe storage and initial curing of the concrete test specimens as required by AASHTO T 23. This shall include a sampling receptacle, a means of transporting the initial concrete sample from the placement location to the testing location, a level and protected area of adequate size to perform testing, and a specimen storage container capable of maintaining the temperature and moisture requirements for initial curing. The distance from the location of concrete placement to the location of testing and initial curing shall be 100 feet or less, unless otherwise allowed by the Engineer.

The specimen storage container described in this section is in addition to the concrete cylinder curing box provided for elsewhere in the Contract. After initial curing, the test specimens will be

transported by Department personnel and stored in the concrete cylinder curing box until they can be transported to the Department's laboratory for strength evaluation. The results of this evaluation shall not be used to control stages or progression of the work in the field as further described in 6.01.03-II-5.

- (c) **Sampling Procedure for Pumping:** It is the responsibility of the Contractor to provide concrete that meets specification at the point of placement.

Samples of concrete shall be taken at the discharge end of the pump at the point of placement except for underwater concrete. The Contractor may submit an alternate location to provide a sample from the discharge end of the pump with verification showing that the characteristics of the mix will not be altered from that of which would have been attained at the point of placement. The Engineer will review the documentation and other extenuating circumstances when evaluating the request.

In the case of underwater concrete the Contractor shall submit the proposed sampling location with the submittals required in 6.01.03-II-6(f).

- (d) **Additional field testing:** Additional field testing such as density and yield measurements may be required at the time of placement as determined by the Engineer.

5. Progression Cylinders and Compressive Strength Specimens: Progression Cylinders outlined in this section are field cured compressive strength specimens taken for information related to when a structure or segment of a structure can be loaded or put into service, adequacy of curing and protection of concrete in the structure, or when formwork or shoring may be removed from the structure. The information produced from strength results of Progression Cylinders will not be considered for acceptance of the concrete.

The personnel, equipment, and molds for sampling, casting, curing and testing of Progression Cylinders shall be furnished by the Contractor at no expense to the Department.

Sampling, casting, and field curing of the specimens shall be performed in accordance with AASHTO T23 by an ACI Concrete Field Testing Technician Grade 1 or higher and will be witnessed by a representative of the Department.

The sample shall be taken at the point of placement into the forms or molds from 1 or more of the same truck loads that an Acceptance sample is taken from.

A minimum of 2 of cylinder results will be used to determine in-place strength.

Compression testing shall be performed in accordance with AASHTO T 22 by personnel approved by the Engineer.

A Certified Test Report in accordance with 1.06.07 or 1.20-1.06.07 shall be provided to the Engineer reporting the Progression Cylinder test results. A copy of the results of the compressive strength testing shall be provided to the Engineer at least 24 hours prior to any Project activity that the results may control.

6. Handling and Placing Concrete: Concrete shall be handled, placed, and consolidated by methods acceptable to the Engineer that will not segregate the mix and shall result in a dense homogeneous concrete. The methods used shall not cause displacement of reinforcing steel or other materials to be embedded in the concrete. Concrete shall not be placed until the forms and all materials have been inspected by the Engineer. All mortar from previous placements, debris, and foreign material shall be removed from the forms and steel prior to commencing placement. The forms and subgrade shall be thoroughly moistened with water immediately before concrete is placed. All water that has ponded within the forms shall also be removed. Temporary form spreader devices shall not be left in place.

All laitance or unsound material shall be removed before placing substructure concrete onto the surface of any concrete placed underwater.

Placement of concrete for each section of the structure shall be performed continuously between construction or expansion joints as shown on the plans. The delivery rate, placing sequence and methods shall be such that fresh concrete is always placed and consolidated against previously placed concrete before initial set has occurred. The temperature of the concrete mixture during placement shall be maintained between 60°F and 90°F. During and after placement of concrete, care shall be taken not to damage the concrete or break the bond with reinforcing steel. Platforms for workers and equipment shall not be supported directly on any reinforcing steel. Forces that may damage the concrete shall not be applied to the forms or reinforcing steel.

- (a) **Sequence of Placement:** The sequence of placement shall be in accordance with the Contract or as permitted by the Engineer.

Concrete for integral horizontal members, such as caps, slabs, or footings shall not be placed until

the concrete for the columns, substructure, culvert walls and similar vertical members has achieved sufficient strength as stated in 6.01.03-II-1(m).

The concrete in arches shall be placed in such a manner as to load the formwork uniformly and symmetrically.

The base slab or footings of cast-in-place box culverts shall reach sufficient strength before the remainder of the culvert is constructed.

- (b) Placement Methods:** The Contractor shall notify the Engineer at least 24 hours in advance of intention to place concrete.

Vibrators shall not be used to shift the fresh concrete horizontally. Vibrators shall be adequate to consolidate the concrete and integrate it with the previous lift.

The rate of concrete placement must not produce loadings that exceed those considered in the design of the forms.

The use of chutes and pipes for conveying concrete into the forms must be reviewed by the Engineer. Chutes shall be clean, lined with smooth watertight material and, when steep slopes are involved, shall be equipped with baffles or reverses. When the discharge must be intermittent, a hopper or other device for regulating the discharge shall be provided.

Aluminum shall not be permanently incorporated into the concrete unless otherwise specified.

When placing operations involve dropping the concrete more than 5 feet, the Contractor shall take action to prevent segregation of the mix and spattering of mortar on steel and forms above the elevation of the lift being placed. This restriction shall not apply to cast-in-place pilings.

When using stay-in-place forms, concrete shall not be dropped more than 3 feet above the top of the forms, and the concrete shall be discharged directly over the beams or girders.

- (c) Pumping:** The Contractor shall use equipment specifically manufactured to pump concrete mixes and that meets the needs of the specific concrete placement.

- (d) Consolidation:** Unless otherwise specified, all concrete, except concrete placed under water, shall be sufficiently consolidated by mechanical vibration immediately after placement.

The Contractor shall provide a sufficient number of commercially available mechanical immersion type vibrators to properly consolidate the concrete immediately after it is placed in the forms unless external form vibrators are used. The Contractor shall have an adequate number of operable vibrators available in case of breakdown.

External form vibrators may be used if submitted prior to concrete placement and reviewed by the Engineer.

Vibration shall not be applied directly to the reinforcement or hardened concrete. Special care shall be taken in placing and consolidating concrete around ornamental moulds, form liners and other embedded items. The vibrator shall not touch these items at any time.

- (e) Additional Requirements for Bridge Decks:** At least 15 days before the erection of the screed rails, the Contractor shall submit screed erection plans, grades and sequence of concrete placement and proposed rate of placing concrete for review by the Engineer. These plans shall include details of equipment to be used in the placement and finishing of the concrete, including the number and type of personnel who will be engaged in placing the concrete. The screed equipment shall be a commercially available vibratory system. The use of wooden screeds is prohibited.

When setting screed rails for mechanical finishing, the Contractor shall take into consideration and make proper allowances for the deflection of the bridge superstructure due to all operations.

Screed and runway supports shall not be located on any stay-in-place metal form sheets, form supports or reinforcing steel. The Contractor shall operate the mechanical screed at least 24 hours prior to actual placement of the concrete to verify deck survey and equipment operations to the satisfaction of the Engineer.

A Pre-Placement Meeting shall be held on the Project Site with the Contractor, Engineer and concrete supplier 48 hours before the concrete deck pour. The Pre-Placement Meeting will document and include discussion on the following topics:

1. Schedule:

- (a)** Deck pour sequence
- (b)** Daily start and finish times for concrete delivery
- (c)** Anticipated completion time

2. Key Personnel:

- (a)** Concrete placement foreman

- (b) Total number of personnel involved in deck pour and their roles during the pour
 - (c) Concrete supplier
 - (d) Concrete pump truck operator/service
 - (e) Discuss QC/QA
3. **Placement:**
- (a) List of approved delivery trucks per pour
 - (b) Pre-wetting forms prior to placement
 - (c) Placement sequence
 - (d) Rate of concrete placement and vibrator process
 - (e) Monitor concrete temperature during placement
 - (f) Transverse joint bulkheads
 - (g) Qualified concrete low-permeability mix design
4. **Curing:**
- (a) Curing materials (burlap, quilted blankets, etc.)
 - (b) Means for pre-soaking curing materials.
 - (c) Foggers
 - (d) Soaker hoses
 - (e) White Plastic Sheeting
 - (f) Water source and supply tanks

Concrete shall be deposited in a uniform manner across the entire width being placed, and only 2 passes of the transverse screed will be permitted over a given deck area, unless otherwise allowed by the Engineer.

If the Contractor proposes to place concrete outside of daylight hours, an adequate lighting system must be provided.

Concrete shall be deposited in accordance with the placement sequence as noted on the plans. If no sequence is indicated, the Contractor shall provide a placement sequence to the Engineer for review. The placement sequence shall proceed in such a manner that the total deflection or settlement of supporting members, and the final finishing of the surface will occur before the initial set of the concrete takes place.

At construction joints, concrete shall not be placed against the previously placed concrete for at least 12 hours unless otherwise allowed by the Engineer.

- (f) **Underwater Placement:** Concrete may only be placed under water within a cofferdam unless otherwise specified in the Contract or allowed by the Engineer. Placement shall begin following inspection and acceptance of the depth and character of the foundation material by the Engineer.

Underwater concrete mixes are considered non-standard designs and shall be submitted to the Engineer for approval. Typically a minimum of 10% additional cement than comparable non-underwater mixes will be required.

Underwater concrete shall be placed continuously with the surface of the concrete kept as horizontal as practical. To ensure thorough bonding, each succeeding layer shall be placed before the preceding layer has taken initial set. For large concrete placements, more than 1 tremie or pump shall be used to ensure compliance with this requirement.

Mass concrete placement requirements, outlined in 6.01.03-II-6(g), do not apply to underwater concrete.

To prevent segregation, underwater concrete shall be placed in a compact mass, in its final position, by means of a tremie, concrete pump, or other approved method and shall not be disturbed. Still water shall be maintained at the point of deposit. Cofferdams shall be vented during the placement and curing of the concrete to equalize the hydrostatic pressure and thus prevent flow of water through the concrete.

If a tremie is used, the method of depositing the concrete shall be detailed in a submission to the Engineer as a working drawing for review. The tube shall have watertight couplings and shall permit the free movement of the discharge end over the area of the work.

- (g) **Mass concrete placement:** Mass concrete placement shall be defined as any placement, excluding underwater concrete placement, in which the concrete being cast has dimensions of 5 feet or greater in each of 3 different directions. For placements with a circular cross-section, a mass concrete placement shall be defined as any placement that has a diameter of 6 feet or greater and a height of 5

feet or greater. For all mass concrete placements, the mix temperature shall not exceed 85°F as measured at point of discharge into the forms.

Any special concrete mix design proposed by the Contractor to meet the above temperature requirements shall be submitted to the Engineer for review.

7. Finishing Plastic Concrete: Unless otherwise specified in the Contract, after concrete has been consolidated and prior to final curing, all surfaces of concrete that are not placed against forms shall be struck-off to the planned elevation or slope. The surface shall be finished by floating with an acceptable tool. While the concrete is still in a workable state, all construction and expansion joints shall be tooled with an edger. Joint filler shall be left exposed. For requirements on float finish, refer to 6.01.03-II-10, Finishing Concrete Surfaces.

After completion of the placing and finishing operation and for at least 12 hours after the concrete has set, the Contractor shall not operate any equipment in the immediate vicinity of the freshly placed concrete if, in the judgment of the Engineer, it could cause excessive vibration, movement or deflection of the forms.

The addition of water to the surface of the concrete to assist in finishing operations will not be permitted.

(a) Bridge Decks: After the concrete has been consolidated and brought to the proper elevation by the screed machine, it shall be finished by use of a suitable float. The Contractor shall not disturb the fresh concrete after it has been finished. All finishing work, including the application of the fog spray and placement of the curing mats, shall be performed from work bridges supported above the deck surface. A work bridge shall be made available to the Engineer for inspection of the concrete work.

Surfaces that are to be covered with a waterproofing membrane shall be finished to a smooth surface, free of mortar ridges and other projections and in accordance with the membrane manufacturer's recommendations.

Unless otherwise noted in the Contract, the concrete wearing surfaces shall be given a skid-resistant texture by dragging, brooming, tining, or by a combination of these methods. These methods shall be done after floating and at such time and in such manner that the desired texture will be achieved while minimizing displacement of the larger aggregate particles.

1. **Dragging:** The surface shall be finished by dragging a seamless strip of damp burlap over the surface. The burlap to be dragged shall consist of sufficient layers and have sufficient length in contact with the concrete to slightly groove the surface. The burlap shall be drawn longitudinally along the surface in a slow manner so as to leave an even texture. The burlap shall be kept damp, clean, and free of particles of hardened concrete. The Contractor may propose an alternate material for the Engineer's consideration.
2. **Tining:** Tining shall be in a transverse direction using a wire broom, comb, or float having a single row of tines or fins. The tining grooves shall be between 1/16 inch and 3/16 inch wide and between 1/8 inch and 3/16 inch deep, spaced 1/2 inch to 3/4 inch on centers. Tining shall be discontinued 12 inches from the curb line on bridge decks. The area adjacent to the curbs shall be given a light broom finish longitudinally. As an alternative, tining may be achieved using a machine designed specifically for tining or grooving concrete pavements.

The transverse grooving shall be performed when the grooves can be formed to a maximum depth of 3/16 inch with relative ease and without the walls of the grooves closing in on each other. The tining shall be aligned so as to prevent overlapping of grooves in any 2 successive transverse passes. The Contractor shall measure the depth of the grooves in the presence of the Engineer with an appropriate device to ensure compliance.

(b) Surface Testing and Correction: The completed surface shall be constructed in accordance with grades and cross slopes shown on the plans. The entire surface shall be checked by the Contractor in the presence of the Engineer, with an acceptable 10 foot straightedge.

1. The surface shall not vary more than +/- 1/8 inch over 10 feet for decks which will not be covered with an overlay.
2. The surface shall not vary more than +/- 1/4 inch over 10 feet for decks which will be covered with an overlay.

Variances greater than these, which, in the judgment of the Engineer, may adversely affect the riding qualities of the surface shall be corrected, and this shall be done at the expense of the Contractor. The Contractor shall submit a corrective procedure to the Engineer for review and approval. The procedure shall correct such irregularities by methods such as, but not limited to, concrete planing or grooving.

8. Bearing Surfaces: Concrete surfaces under metallic masonry plates and elastomeric bearings shall have a float finish. After the concrete has set, the area which will be in contact with the masonry plate shall be ground as necessary to provide full and even bearing. The finished surface shall not vary from a straightedge laid on the surface in any direction within the limits of the masonry plate by more than 0.0625 inch. Surfaces which fail to conform shall be ground or filled until acceptable to the Engineer.

9. Curing Concrete: All newly placed concrete shall be cured to prevent loss of water by use of the methods specified. The Engineer may request that the Contractor furnish a curing plan.

The duration of the initial and final curing period in total shall continue uninterrupted for a minimum of 7 days.

(a) Curing Methods:

1. **Forms-In-Place Method:** Formed surfaces of concrete may be cured by retaining the forms in place without loosening. During periods of hot weather, water shall be applied to the forms until the Engineer determines that it is no longer required.
2. **Water Method:** Exposed concrete surfaces shall be kept continuously wet by ponding, spraying, or covering with materials that are kept continuously and thoroughly wet. Such materials may consist of cotton mats, multiple layers of burlap, or other approved materials that do not discolor or otherwise damage the concrete.
3. **Waterproof Cover Method:** This method shall consist of covering exposed surfaces with a waterproof sheet material to prevent moisture loss from the concrete. The concrete shall be wet at the time the cover is installed. The sheets shall be of the widest practicable width and adjacent sheets shall overlap a minimum of 6.0 inches to form a waterproof cover of the entire concrete surface and shall be adequately secured. Broken or damaged sheets shall be immediately repaired and the concrete shall be remoistened.

(b) Additional Requirements for Bridge Decks:

Curing Plan: The Contractor shall submit to the Engineer, at least 14 days prior to the placement of concrete for the bridge deck, a detailed curing plan that describes the following:

- A. the initial and final curing durations,
 - B. equipment and materials to be used for curing concrete and monitoring concrete temperature,
 - C. and proposed primary and secondary water and heat sources
1. **Initial Curing Period:** A water fog spray shall be used by the Contractor from the time of initial placement until the final curing period begins. The amount of fog spray shall be strictly controlled so that accumulations of standing or flowing water on the surface of the concrete shall not occur.
Should atmospheric conditions render the use of fog spray impractical, the Contractor shall request approval from the Engineer to use a curing compound that meets the requirements of M.03 in lieu of a fog spray. The application shall be in accordance with the manufacturer's recommendation and be compatible with the membrane waterproofing.
 2. **Final Curing:** After completion of finishing and as soon as any bleed water has dissipated and the concrete reaches sufficient strength to avoid marring, the Final curing period shall begin and the entire concrete surface shall be covered with water-retaining materials such as cotton mats, multiple layers of burlap, or other materials approved by the Engineer. Materials used shall be kept saturated by means of an acceptable sprinkler or wetting system.
The Contractor may cover the wet water-retaining material with a suitable polyethylene film to minimize evaporation during the curing period. The use of the polyethylene film does not relieve the Contractor from maintaining saturation of the curing materials.
 3. **Temperature Monitoring:** The internal temperature of the concrete shall be monitored with a calibrated continuous recording thermometer for a minimum of 7 days. The air temperature at the concrete surface or the air temperature between the concrete surface and its protective covering shall be monitored with a minimum of 1 recording thermometer.
The number and placement of the thermometers will be determined by the Engineer. A minimum of 2 thermometers per concrete placement shall be provided by the Contractor.
The following types of thermometers shall be used to monitor curing temperatures:
 - i) **Continuously Recording Thermometer:** The thermometer shall be capable of continuously recording temperatures within a range of -4°F to 122°F for a minimum of 24 hours.
 - ii) **Maximum-Minimum Recording Thermometer:** For all placements, the thermometer shall be capable of recording maximum and minimum temperatures in a range of -4°F to 122°F.

10. Finishing Concrete Surfaces: Any minor repairs due to fins, bulges, offsets and irregular projections shall be performed immediately following the removal of forms. For areas of newly placed concrete that are honeycombed or segregated the Contractor shall provide a written corrective procedure for review by the Engineer prior to the work being performed. Construction and expansion joints in the completed work shall be left carefully tooled and free of mortar and concrete. The joint filler shall be left exposed for its full length with clean and true edges.

The cavities produced by form ties and all other holes, broken corners or edges, and other defects shall be cleaned, saturated with water, pointed and trued with a mortar conforming to M.11.04. Cement similar in color to the exposed surface being repaired shall be added to the mortar. Mortar used in pointing shall be used within 1 hour of mixing. The concrete shall be finished as defined below if required and the cure continued as previously specified in 6.01.03-II-9, Curing Concrete.

Finishing work shall not interrupt the curing period unless permitted by the Engineer. The curing period may be extended to provide the minimum total number of days required.

Concrete surface finishes shall be classified as follows:

- (a) **Float Finish:** This finish shall be achieved by placing an excess of material in the form and removing or striking off of such excess forcing the coarse aggregate below the mortar surface. Concave surfaces in which water will be retained will not be allowed. After the concrete has been struck off, the surface shall be thoroughly worked and floated. Before this last finish has set, the surface shall be lightly stripped with a fine brush to remove the surface cement film, leaving a fine-grained, smooth, but sanded texture. Curing, as specified elsewhere, shall follow. Any surfaces that will support appurtenances such as light standards, railing, or fences shall be finished in accordance with 6.01.03-II-8, Bearing Surfaces.
- (b) **Rubbed Finish:** The initial rubbing shall only be allowed within 3 days after placement. The entire surface shall be thoroughly wet with a brush and rubbed with a No. 16 Carborundum Stone or an abrasive of equal quality, bringing the surface to a paste. The rubbing shall be continued sufficiently to remove all form marks and projections, producing a smooth, dense surface without pits or irregularities. The paste formed by the rubbing may be finished by **striping** with a clean brush, or it may be spread uniformly over the surface and allowed to re-set. If all or portions of the rubbed surface are unacceptable to the Engineer or a rubbed finish is not provided within 3 days after removal of forms, the Contractor will be directed to provide a grout clean down finish.
- (c) **Grout Clean-Down Finish:** As soon as all cavities have been filled as required elsewhere and the cement mortar has set sufficiently, grout clean-down shall be performed. All burrs, unevenness, laitance, including that in air holes, and any other material which will adversely affect the bond of the grout to the concrete, shall be removed by acceptable methods. This cleaning shall be done from the top or uppermost part of the surface to be finished to the bottom.

A mixture of a fine aggregate and Portland cement shall be thoroughly blended while dry. The proportions shall be such that when mixed with the proper amount of water, the color will match that of the concrete to be finished. Water shall be added to this mixture in an amount which will bring the grout to a workable thick paint-like consistency.

The surface to be treated shall be thoroughly wetted with enough water to prevent the absorption of water from the grout. Grout shall then be applied to the wetted surface before setting of the grout occurs. Grout which has set shall not be re-tempered and shall be disposed of by the Contractor at no cost to the State.

The grout shall be uniformly applied over the entire surface, completely filling all air bubbles and holes. Immediately after applying the grout, the surface shall be floated with a suitable float, scouring the surface vigorously. While the grout is still plastic, all excess grout shall be removed.

After the final rubbing is completed and the surface has dried, it shall be rubbed to remove loose powder and shall be left free from all unsound patches, paste, powder, and objectionable marks. Wetting, application and removal of excess grout shall be completed in 1 work shift.

All finished surfaces shall be cured for a minimum of 24 hours. Horizontal surfaces shall have a float finish and vertical exposed surfaces shall have a rubbed finish. A grout clean-down finish may be substituted for a rubbed finish as noted in this article or as directed by the Engineer.

11. Mortar, Grout, Epoxy and Joint Seal:

- (a) **Mortar and Grout:** This work consists of the making and placing of mortar and grout. At least 48 hours prior to the planned use, a copy of the installation instructions and MSDS sheets shall be

provided to the Engineer for review and concurrence of their applicability and for verification of proper hole sizes in concrete structures. Such uses include mortar for filling under masonry plates, mortar used to fill voids and repair surface defects, grout used to fill sleeves for anchor bolts, and mortar and grout for other such uses where required.

Concrete areas to be in contact with the mortar or grout shall be cleaned of all loose or foreign material that would in any way prevent bond, and the concrete surfaces shall be flushed with water and allowed to dry until no free-standing water is present.

The mortar or grout shall completely fill and shall be tightly packed into recesses and holes, on surfaces, under structural members, and at other locations specified. After placing, all surfaces of mortar or grout shall be cured as previously specified in 6.01.03-II-9(a)-2, for a period of not less than 3 days.

- (b) **Epoxy:** The epoxy shall be prepared and placed in accordance with the manufacturer's directions and with the equipment prescribed by the manufacturer. Instructions furnished by the supplier for the safe storage, mixing, handling and application of the epoxy shall be followed. Contents of damaged or previously opened containers shall not be used.
- (c) **Joint Seal:** This work consists of sealing joints where shown on the plans or as otherwise directed by the Engineer.

Before placement of the sealing material, the joints shall be thoroughly cleaned of all scale, loose concrete, dirt, dust or other foreign matter. Projections of concrete into the joint space shall be removed. The joint shall be clean and dry before the sealing compound is applied.

The joint sealant shall be prepared and placed in accordance with the manufacturer's directions and with the equipment prescribed by the manufacturer. The sealing compound shall be flush with, or not more than 1/8 inch above the adjacent surface of concrete, cutting off all excess compounds after the application. The joints shall be sealed in a neat and workmanlike manner and when the work is completed, the joints shall effectively seal against infiltration of moisture and water.

The Contractor shall arrange for, and have present at the commencement of the joint-sealing operation, a technically competent manufacturer's representative knowledgeable in the methods of installation of the sealant. The Contractor shall also arrange to have the representative present at such other times as the Engineer may request.

- (d) **Closed Cell Elastomer:** The closed cell elastomer shall be of the thickness specified and installed as shown on the plans and shall be in accordance with M.03.08-6.

12. Application of Loads: Loads shall not be applied to concrete structures until the concrete has attained sufficient strength and, when applicable, sufficient pre-stressing and post tensioning has been completed, so that damage will not occur. The means to determine when the concrete has attained sufficient strength shall be the use of Progression cylinders as defined in 6.01.03-II-5, or other means allowed in advance by the Engineer.

- (a) **Earth Loads:** The placement of backfill shall not begin until the concrete is cured and has reached at least 80% of its specified strength unless otherwise permitted by the Engineer. The sequence of placing backfill around structures shall minimize overturning or sliding forces and flexural stresses in the concrete.
- (b) **Construction Loads:** Light materials and equipment may be hand carried onto bridge decks only after the concrete has been in place at least 24 hours providing curing is not interfered with and the surface texture is not damaged.

Prior to the concrete achieving its specified compressive strength, any other live or dead loads imposed on existing, new, or partially completed portions of structures, shall not exceed the reduced load carrying capacity of the structure, or portion of structure. The Contractor may be required to submit calculations to the Engineer that verify these requirements are being met. The compressive strength of concrete ($f'c$) to be used in computing the load-carrying capacity shall be the smaller of the actual field compressive strength at the time of loading or the specified design strength of the concrete. The means to determine the actual field compressive strength shall be approved by the Engineer.

For post-tensioned structures, no live or dead loads shall be allowed on any span until the steel for that span has been tensioned.

- (c) Precast concrete or steel girders shall not be placed on substructure elements until the substructure concrete has attained 85% of its specified strength.

No load shall be allowed on mortar or grout that has been in place less than 72 hours.

(d) **Traffic Loads:** The concrete deck will not be opened to traffic until at least 14 days after the last placement of deck concrete and until such concrete has attained its specified strength.

13. Dispute Resolution: The basis of any dispute resolution is side-by-side and quality control testing by the Contractor or the Contractor's representative. The Contractor and Engineer should perform independent testing on the material to reasonably establish the true characteristics of the material at the time of delivery. Absent of Contractor QC testing, the Engineer's test results will apply to the quantity of concrete represented by the sample, not to exceed 75 c.y.

Air Content: Contractor QC Testing must be performed by personnel qualified by The American Concrete Institute as an ACI Concrete Field Testing Technician Grade 1 or higher and performed in accordance with AASHTO T 23. If the Contractor's test results vary from those of the Engineer, the Contractor shall immediately notify the Engineer of the difference and work cooperatively to determine the reasonable cause and recognize the valid test. Should there be agreement, the result of the valid test will be used for acceptance and adjustment purposes for that lot of material. Should there not be an agreement as to the valid test, an additional set of tests should be performed. Results of all valid tests on the same lot may be averaged and used for acceptance and adjustment purposes. Should the Contractor wish to perform additional QC testing on subsequent material, the lot sizes may be adjusted to the amount of material included in that specific delivery. Any such QC testing must be witnessed and agreed to by the Engineer.

Compressive Strength: Contractor QC testing for compressive strength must be performed in accordance with AASHTO T 22 by personnel approved by the Engineer. Samples used to dispute the Engineer's test results must be made simultaneously and from the same batch of concrete. Should the Contractor wish to pursue a dispute resolution regarding compressive strength, the Contractor shall submit in writing to the Engineer all test results, control charts, or other documentation that may be useful in determining if the specific lot(s) of material met the Contract specifications. The Engineer will consider the submittal and may average specific test results on the disputed lot(s) for acceptance and adjustment purposes. Destructive testing of any kind on the placed concrete structure will not be allowed.

III. Additional Requirements for Surface Repairs and Structural Repairs

1. Work Area Access and Shielding: Prior to removal of existing concrete, the Contractor shall provide access to the anticipated work areas so that the inspector and the Contractor may together determine and delineate the exact limits and locations of the work.

The Contractor shall design, furnish, install and remove a shield(s) to prevent debris from entering areas adjacent or beneath the work. The Contractor shall submit working drawings to the Engineer in accordance with 1.05.02. The shield(s) shall be maintained by the Contractor and remain in place during all phases of the repair work.

2. Concrete Removal: The perimeter of each area to be repaired shall be saw cut as shown on the plans. All concrete within that area shall be removed to at least 1 inch beneath any visible reinforcing steel and to sound concrete. The reinforcing steel shall not be damaged or its bond in the surrounding concrete. The Contractor must use fifteen (15) pound hammers or other methods accepted by the Engineer.

In addition to removal of concrete to a depth of 1 inch below reinforcing steel, localized areas of removal may be required if embedded galvanic anodes are specified in the Contract, to allow a minimum of 2 inches of concrete cover over the anodes.

Any steel reinforcing scheduled to be left in place that is damaged during the concrete removal process shall be replaced in accordance with 6.02 to the satisfaction of the Engineer and at the expense of the Contractor.

Corroded, missing, or broken reinforcing steel shall be replaced in accordance with 6.02 and as shown on the plans or as directed by the Engineer.

The Contractor shall perform the work in a manner that prevents debris from entering roadway lanes or areas below the structure. All debris shall be removed from the Site and disposed of by the Contractor.

3. Surface Preparation: All newly exposed surfaces of concrete shall be sandblasted and be visibly free from oil, solvent, grease, loose particles, or any other foreign matter. Exposed reinforcing steel shall be sandblasted in accordance with SSPC-SP-6, Commercial Blast Cleaning, to remove all contaminants, rust and rust scale.

4. Installation of Embedded Galvanic Anodes: After sandblasting reinforcing steel, galvanic anodes shall be embedded where shown on the plans and in accordance with the Contract.

5. Welded Wire Fabric in Vertical and Overhead Surface Repairs: Prior to installing formwork, steel welded wire fabric meeting the requirements of M.06.01-3 shall be installed at the proper depth in those

areas as shown on the plans or directed by the Engineer. The fabric shall be tied to exposed reinforcing steel or anchored to sound concrete using means approved by the Engineer.

6. Formwork: Forms and support systems shall be designed in accordance with 6.01.03-II-1. Forms shall be so designed so that access is from the top of the formwork. If access is not possible from the top of the formwork, the Contractor shall submit a method of concrete placement for review by the Engineer.

7. Concrete Placement and Curing: Bonding compounds shall not be used before or during the placement of the concrete. Exposed surfaces shall be wetted with water immediately prior to placement. There shall be no excessive water on the surface or in the formwork. Light rust on sandblasted reinforcing steel can be anticipated and is acceptable.

The temperature of the air and surface to be repaired at the time of placement and curing shall be a minimum of 45°F. Concrete shall be placed and consolidated immediately with appropriate vibratory equipment.

Forms shall be kept moist and shall be left in place for a minimum of 7 days or as shown on the plans.

8. Form Removal and Sequence of Repair: Form removal shall be in accordance with 6.01.03-II-1(m) unless otherwise noted on the plans. The Contractor shall follow the sequence of repairs shown on the plans.

9. Finishing: Immediately following curing and form stripping, the exposed faces shall be finished in accordance with 6.01.03-II-10(c) Grout Clean-Down Finish.

10. Sounding of Completed Repairs: Cured and finished areas may be sounded by the Engineer to detect the presence of subsurface voids or delamination. Such areas shall be removed and replaced by the Contractor at its expense until an acceptable repair is in place as determined by the Engineer.

11. Sealing Concrete Surfaces: After all repairs have been accepted, penetrating sealer shall be applied in accordance with the Contract to the repaired areas as well as all contiguous areas to the repair or as directed by the Engineer.

6.01.04—Method of Measurement: This work will be measured for payment as follows:

1. Concrete used for new construction: The quantity of concrete used for new construction will be the actual volume in cubic yards of the specified class, except for underwater concrete, completed and accepted within the neat lines as shown on the plans or as ordered by the Engineer. Parapets will be measured for payment by the number of linear feet of parapet, completed and accepted. The length of parapet will be measured along the centerline of the top of the parapet.

When concrete is placed against bedrock, a maximum of 6 additional inches beyond the neat lines can be measured for payment.

No deduction will be made for panels, form liners, reinforcing bars, structural steel shapes or for pile heads. There will be no deduction made for the volume occupied by culvert and drainage pipes, scuppers, weep holes, public utility structures or any other opening, unless the surface area of any such single opening is 9 s.f. or more.

In the case of culverts or drainage pipes, the computation of the surface area will be based on the nominal diameter of the pipe, disregarding the thickness of the shell.

Miscellaneous materials necessary for completion of the work such as felt, mortar, grout, epoxy and joint seal will not be measured for payment.

Incidental work such as forming for anchor bolts, utilities, keyways, and sampling and testing will not be measured for payment.

The work to produce and administer the Concrete Quality Control Plan (CQCP) will not be measured for payment.

2. Underwater Concrete: When underwater concrete is used, it will be measured by the volume in cubic yards within the actual horizontal limits of the cofferdam and between the elevations established by the Engineer.

3. Concrete used for Surface or Structural Repairs: The quantity of concrete used for surface repairs or structural repairs will be the actual volume completed and accepted. Welded wire fabric used in repair areas will not be measured for payment.

4. Joint Filler: This material will be measured by the area in square feet of the joint filler, of the type and thickness specified, installed and accepted.

5. Closed Cell Elastomer: This material will be measured by the volume in cubic inches of elastomer, of the thickness specified, installed and accepted.

6.01.05—Basis of Payment: Payment for this work will be made as follows:

1. Concrete: Progress payments may be allowed for completed major labor elements of work such as forming, placing and curing. Prior to placement, the Contractor shall submit a proposed schedule of values for review and approval by the Engineer.

Payment for any lot of concrete allowed to remain in place will be adjusted when the field and laboratory testing of the material is completed. The quantity of concrete in each lot for new construction will be a maximum of 75 c.y. Payment for each lot of concrete will be adjusted based on the results of the acceptance testing performed by the Engineer.

The pay factors listed in Table 6.01.05-1 apply for Standard and Modified Standard Mix classes with regard to entrained air content.

Table 6.01.05-1 Entrained Air Content Pay Factors

Specified Entrained air (%)*				Pay factor (%)
6.0 +/- 1.5%		7.5 +/- 1.5%		1.00 (100)
4.3 and 4.4	7.6 and 7.7	5.8 and 5.9	9.1 and 9.2	0.98 (98)
4.1 and 4.2	7.8 and 7.9	5.6 and 5.7	9.3 and 9.4	0.96 (96)
3.9 and 4.0	8.0 and 8.1	5.4 and 5.5	9.5 and 9.6	0.94 (94)
3.7 and 3.8	8.2 and 8.3	5.2 and 5.3	9.7 and 9.8	0.92 (92)
3.5 and 3.6	8.4 and 8.5	5.0 and 5.1	9.9 and 10.0	0.90 (90)
Concrete lots with less than 3.5% or greater than 8.5% entrained air will be rejected.		Concrete lots with less than 5.0% or greater than 10% entrained air will be rejected.		
*Air content measured at time and point of placement				

The pay factors listed in Table 6.01.05-2a apply for Standard and Modified Standard Mix classes with regard to compressive strength.

Table 6.01.05-2a Compressive Strength Pay Factors

Compressive Strength (%)	Pay factor (%)
95 or greater	1.00 (100)
90 to 94.9	0.95 (95)
85 to 89.9	0.90 (90)
*Measured at 28 days	
Concrete lots with less than 85% specified strength will be rejected.	

The pay factors listed in Table 6.01.05-2b apply for Standard and Modified Standard Mix classes with regard to surface resistivity when specified in accordance with AASHTO T 358 using 4 inch × 8-inch cylinders.

Table 6.01.05-2b Permeability Pay Factors (PCCXXXX2 mix classifications only)

Surface Resistivity (kΩ-cm)*	Pay factor (%)
37 or greater	1.1 (110)
29 to 36.9	1 (100)
25 to 28.9	0.85 (85)
21 to 24.9	0.75 (75)
*Measured at 56 days	
Concrete lots with resistivity values less than 21 will be rejected.	

The payment adjustment value for entrained air, 28-day strength, and permeability if applicable, for any lot of concrete for new construction that is allowed to remain in-place is determined using the formulas listed in Table 6.01.05-3a. An Index Price of \$400.00 per c.y. will be used to calculate each adjustment, except for Parapet Concrete, for which an Index Price of \$100 per l.f. will be used. The sum of the individual adjustment values will be deducted from the cubic yard or linear foot payment for the appropriate item.

Table 6.01.05-3a Payment Adjustment Formulas for New Construction

$\text{Adj (air)} = (1 - \text{air pay factor}) \times \text{Index Price} \times \text{lot size (c.y. or l.f.)}$
$\text{Adj (strength)} = (1 - \text{strength pay factor}) \times \text{Index Price} \times \text{lot size (c.y. or l.f.)}$
$\text{Adj (permeability)} = (1 - \text{permeability pay factor}) \times \text{Index Price} \times \text{lot size (c.y. or l.f.)}$
$\text{Total Adjustment} = \text{Adj (air)} + \text{Adj (strength)} + \text{Adj (permeability)}$

The payment adjustment value for entrained air and 28-day strength for any lot of repair concrete that is allowed to remain in-place is determined using the formulas listed in Table 6.01.05-3b. An index price of \$200.00 per c.f. shall be used to calculate each adjustment. The total adjustment value will be the sum of each individual adjustment value and will be deducted from the cubic foot payment for the appropriate item.

Table 6.01.05-3b Payment Adjustment Formulas for Repair Concrete

$\text{Adj (air)} = (1 - \text{air pay factor}) \times \$200/\text{c.f.} \times \text{lot size (c.f.)}$
$\text{Adj (strength)} = (1 - \text{strength pay factor}) \times \$200/\text{c.f.} \times \text{lot size (c.f.)}$
$\text{Total Adj} = \text{Adj (air)} + \text{Adj (strength)}$

The Contractor shall request permission from the Engineer to remove and replace a lot(s) of concrete to avoid a negative payment adjustment. Any replacement material will be sampled, tested and evaluated in accordance with this specification.

No direct payment will be made for any labor, equipment or materials used during the sampling and testing of the concrete for Progression or Acceptance. The cost shall be considered as included in the general cost of the work or as stated elsewhere in the Contract. The work of transporting the concrete test specimens, after initial curing, for Acceptance testing will be performed by the Department without expense to the Contractor.

This material used for new construction will be paid for at the Contract unit price per cubic yard or linear foot less any adjustments, for the specified class, complete in place, which price shall include all materials, equipment, tools, labor and work incidental thereto, including Concrete Quality Control Plan, heating, all admixtures, joint sealer, roofing felt, and any miscellaneous materials such as metal flashing and metal used in expansion joints and bearings.

2. Underwater Concrete: When this class of concrete is used, it will be paid for at the Contract unit price per cubic yard for "Underwater Concrete," complete in place, which price shall include all materials, equipment, tools, labor and work incidental thereto.

3. Concrete Used For Structural Repairs or Surface Repairs: The material used for structural repairs or surface repairs will be paid for at the Contract unit price per cubic foot less any adjustments, complete in place, which price shall include saw cutting, removing concrete, sandblasting, cleaning, forming, placing, curing, stripping, and finishing new surfaces, and all materials, equipment, tools, labor and clean-up incidental thereto.

4. Joint Filler: Expansion joint filler will be paid for at the Contract unit price per square foot for "Joint Filler for Bridges" of the type and thickness specified, complete in place, which price shall include all materials, equipment, tools, labor and work incidental thereto.

5. Closed Cell Elastomer: Closed cell elastomer will be paid for at the Contract unit price per cubic inch for "Closed Cell Elastomer" of the thickness specified, complete in place, which price shall include all materials, equipment, tools, labor and work incidental thereto.

Embedded galvanic anodes, deformed steel bars, and penetrating sealer, will be paid for separately.

Pay Item	Pay Unit
Footing Concrete	c.y.
Footing Concrete (Mass)	c.y.
Abutment and Wall Concrete	c.y.
Abutment and Wall Concrete (Mass)	c.y.
Column and Cap Concrete	c.y.
Column and Cap Concrete (Mass)	c.y.

Bridge Deck Concrete	c.y.
Bridge Deck Concrete (SIP Forms)	c.y.
Parapet Concrete	l.f.
Bridge Sidewalk Concrete	c.y.
Approach Slab Concrete	c.y.
Barrier Wall Concrete	c.y.
Underwater Concrete	c.y.
Surface Repair Concrete	c.f.
Structural Repair Concrete	c.f.
Class PCCXXXXYZ	c.y.
(Thickness and Type) Joint Filler for Bridges	s.f.
(Thickness) Closed Cell Elastomer	c.i.

**SECTION 6.02
REINFORCING STEEL**

Replace Subarticle 6.02.03-4b with the following:

(b) Support Systems: Reinforcing steel shall be supported in its proper position by use of precast mortar blocks, wire bar supports, supplementary bars (tie-down bars), side form spacers or other approved devices. Such devices shall be sufficiently strong and properly placed at frequent intervals so as to maintain the cover between the reinforcing and the surface of the concrete. **When non-galvanized steel forms are proposed to be used adjacent to galvanized reinforcing bars, non-conductive materials shall be used for bar supports, side form spacers and any other device that could electrically connect the reinforcing to the forms. Metal devices must be properly insulated to protect against electrical conduction.**

The reinforcing steel cover shall be no less than that shown on the plans and no greater than that shown plus 1/4 inch.

Platforms for the support of workers and equipment during concrete placement shall be supported directly on the forms and not on the reinforcing steel.

Replace Subarticle 6.02.03-4d with the following:

(d) Wire Supports: Wire bar supports, such as ferrous metal chairs and bolsters, shall conform to industry practice as described in the CRSI "Manual of Standard Practice of the Concrete Reinforcing Steel Institute." All bolsters or chairs which bear against the forms for exposed surfaces shall be equipped with snug fitting, high density, polyethylene tips which provide 1/2-inch minimum clearance between the metal and any exposed surface. For epoxy-coated reinforcement, all wire bar supports and bar clips shall be epoxy or plastic coated. For galvanized reinforcement, chair and bar supports shall be hot-dip galvanized, after fabrication, in accordance with ASTM A123. **Chair and bar supports between galvanized reinforcing and non-galvanized metal forms shall be made of non-conductive materials. Metal devices must be properly insulated to protect against electrical conduction.**

The maximum spacing of slab bolster rows and high chair rows for concrete deck slabs shall be 4 feet unless otherwise directed by the Engineer.

**SECTION 6.03
STRUCTURAL STEEL**

Replace the first paragraph Article 6.03.01 with the following:

6.03.01—Description: Work under this item shall consist of furnishing, fabricating, inspecting, testing transporting, storing, handling and erecting of both permanent and temporary structural steel of the type and size designated, as shown on the plans or working drawings, as directed by the Engineer and in accordance with these specifications.

Replace Subarticle 6.03.03-4(b) with the following:

- (b) Camber:** All members shall be cambered prior to heat curving and painting. Rolled beams shall be either heat or cold cambered by methods approved by the Engineer. Cold cambering shall not be performed on fracture critical rolled sections, such as beams spaced more than 12 feet on center. For beams with excessive camber requirements (more than 1 1/2 inches per 20 feet of length), cold cambering is prohibited. Plate girders shall be cambered by cutting the web to the prescribed shape with allowances for shrinkage due to cutting, welding, and heat curving. The fabricator is responsible to determine what allowances should be made. Rolled, plate-rolled, or fabricated sections shall be cambered to the total amount shown on the plans and within the camber deviation tolerances permitted for welded beams and girders, as indicated in the ANSI/AASHTO/AWS D1.5 Bridge Welding Code. The Contractor must submit to the Engineer for approval, a cambering procedure that includes a plan for corrective action if the actual camber is not within tolerance.

Replace Subarticle 6.03.03-4(e) with the following:

- (e) Inspection:** The Contractor shall furnish facilities for the inspection of material and workmanship in the shop by the Engineer. The Engineer and any representative of the Engineer shall be allowed free access to the necessary parts of the premises.
- The Engineer will provide Quality Assurance (QA) inspection at the fabrication shop to assure that all applicable Quality Control plans and inspections are adequately adhered to and maintained by the Contractor during all phases of the fabrication. A thorough inspection of a random selection of elements at the fabrication shop may serve as the basis of this assurance.
- I.** Prior to shipment to the Project, each individual piece of structural steel shall be stamped or marked in a clear and permanent fashion by a representative of the fabricators' Quality Control (QC) Department to indicate complete final inspection by the fabricator and conformance to the Project specifications for that piece. The stamp or mark must be dated. A Materials Certificate in accordance with 1.06.07 or 1.20-1.06.07 may be used in lieu of individual stamps or markings, for all material in a single shipment. The Materials Certificate must list each piece within the shipment and accompany the shipment to the Project Site.
 - II.** Following the final inspection by the fabricator's QC personnel, the Engineer may select pieces of structural steel for re-inspection by the Department's QA inspector. Should non-conforming pieces be identified, all similar pieces must be re-inspected by the fabricator and repair procedure(s) submitted to the Engineer for approval. Repairs will be made at the Contractor's expense.
 - III.** The pieces selected for re-inspection and found to be in conformance, or adequately repaired pieces, may be stamped or marked by the QA inspector. Such markings indicate the Engineer takes no exception to the pieces being sent to the Project Site. **Such marking does not indicate acceptance or approval of the material by the Engineer.**

Following delivery to the Project Site, the Engineer will perform a visual inspection of all material to verify shipping documents, fabricator markings, and that there was no damage to the material or coatings during transportation and handling.

The Engineer is not responsible for approving or accepting any fabricated materials prior to final erection and assembly at the Project Site.

Replace the first paragraph of Subarticle 6.03.03-4(f) with the following:

- (f) **Nondestructive Testing:** All nondestructive testing of structural steel and welding shall be performed as designated in the applicable welding code, the plans, and specifications. Such testing shall be performed by personnel approved by the Engineer.

Replace the first paragraph of Subarticle 6.03.03-4(h) with the following:

- (h) **Shipping, Handling, Storage and Receiving:** The Contractor shall make all arrangements necessary to properly load, transport, unload, handle and store all material. The Contractor shall furnish to the Engineer copies of all shipping statements. The weight of the individual members shall be shown on the statements. Members having a weight of more than 3 tons shall have the weight marked thereon. All material shall be unloaded promptly upon delivery. The Contractor shall be responsible for any demurrage charges. Damage to any material during transportation, improper storage, faulty erection, or undocumented fabrication errors may be cause for rejection of said material at the Project Site. Field repairs of damaged or unacceptable coatings will only be allowed if approved by the Engineer.

Replace Subarticle 6.03.03-5(e) with the following:

- (e) **Welded Connections:** Unless otherwise shown on the plans or indicated by the special provisions, welding of structural steel shall be done in accordance with ANSI/AASHTO/AWS D1.5 Bridge Welding Code.

The Contractor's welding and inspection procedures for each type of field weld and field tacking must be submitted to the Engineer on the form designated by the Department. All procedures must be approved by the Division of Materials Testing prior to any work and must be adhered to at all times.

Quality control is the responsibility of the Contractor. The Contractor must provide an AWS Certified Welding Inspector (CWI) in accordance with AWS D1.5. The CWI must be qualified and certified in accordance with the provisions of AWS QC1, *Standard for Qualification and Certification of Welding Inspectors*. The CWI shall make visual inspection of all welds and perform magnetic particle inspection, ultrasonic testing inspection, or radiographic testing inspection of field welds in accordance with the applicable welding code, and contract documents. Each test may be witnessed by an authorized representative of the Engineer. Weld inspection report(s) shall be submitted to the Engineer indicating all visual inspections and physical tests have been performed along with the results of each.

Welds or sections of welds containing imperfections determined to be unacceptable by either the CWI or the Engineer shall be removed and re-welded by the Contractor at their expense. Welds so repaired shall be re-inspected and added to the inspection report(s) by the CWI. All associated costs for such work shall be borne by the Contractor.

*Replace the paragraph after 6.03.03-5(f), **Inspection** with the following:*

Quality Control (QC): The Contractor shall review the project documents with its personnel prior to performing the work. The Contractor shall verify the proper markings, surface conditions and storage of fastener assemblies. The Contractor shall inspect the faying surfaces of connections for compliance with the plans and specifications. The Contractor shall provide to the Engineer a copy of their written QC report for each shift of the calibration or verification testing specified. This report shall confirm that the selected procedure is properly used and that the fastener assemblies installed meet the tensions specified in Table A. The Contractor shall monitor the installation of fasteners in the work to assure that the selected procedure, as demonstrated in the initial testing to provide the specified tension, is routinely and properly applied.

Replace the last paragraph of Article 6.03.05 with the following:

No direct payment will be made for setting anchor bolts, preparing bearing areas, furnishing and placing materials under bearings. No direct payment will be made for **required** non destructive testing.

Pay Item	Pay Unit
Structural Steel (Site No.)	l.s.
Structural Steel	cwt.

After Section 6.09, add the following New Section 6.10:

**SECTION 6.10
DRILLING HOLES AND BONDING
ANCHORS AND DOWELS**

6.10.01 – Description

6.10.01 – Materials

6.10.01 – Construction Methods

6.10.01 – Method of Measurement

6.10.01 – Basis of Payment

6.10.01 - Description: Work under this item consists of drilling holes in concrete and bonding anchors or dowels into the holes with adhesive bonding material as shown on the plans, in accordance with the manufacturer's recommendations, and as directed by the Engineer.

Adhesive bonded anchors are composed of adhesive bonding material and steel anchors, either fully threaded rods or deformed reinforcing bars, with an embedment no greater than 20 times the diameter of the anchor.

Adhesive bonded dowels are composed of adhesive bonding material and deformed steel reinforcing bars embedded no less than the tension development length of the bar calculated using its full yield strength and no greater than 60 times the diameter of the reinforcing bar.

6.10.02 - Materials: For adhesive bonded anchors, the adhesive bonding material shall meet the assessment requirements of ACI 355.4 latest edition and of ICC Evaluation Service (ICC-ES) AC308 *Acceptance Criteria for Post-Installed Adhesive Anchors in Concrete Elements*, including use under sustained tension loads and installation in holes drilled horizontally. The characteristic bond strength of the adhesive bonding material shall meet or exceed the design characteristic bond stress value specified on the plans.

Steel anchors shall meet the requirements specified on the plans.

For adhesive bonded dowels, the adhesive bonding material shall meet the assessment requirements of ACI 355.4 latest edition and of ICC-ES AC308 *Acceptance Criteria for Post-Installed Adhesive Anchors in Concrete Elements* including use under sustained tension loads, installation in holes drilled horizontally, and for use with reinforcing bars embedded the code-required tension development length of the bar. The characteristic bond strength of the adhesive bonding material shall meet or exceed the design characteristic bond stress value specified on the plans.

Dowels shall meet the requirements specified on the plans.

6.10.03 - Construction Methods: The Contractor shall select adhesive bonding material based on, and compatible with, the Site conditions, the requirements shown on the plans, the material's ICC-ES Evaluation Service Report, and the manufacturer's printed installation instructions (MPII).

A. Submittals: Prior to drilling holes for the anchors and dowels, the Contractor shall submit the following to the Engineer for review in accordance with Article 1.05.02 Product Data requirements:

1. A copy of the ICC-ES Evaluation Service Report for the adhesive bonding material. The ICC-ES Evaluation Service Report shall have been issued or reissued no more than 2 years prior to its submission and be valid at the time of installation.
2. A copy of the adhesive bonding material manufacturer's printed installation instructions (MPII)
3. type of drill and diameter of bit
4. method of cleaning holes
5. method of placement of the adhesive bonding material

B. Installation Requirements: The drilling of the holes for the anchors and dowels shall proceed only after the Contractor's Product Data submittal has been reviewed, stamped and returned to the Contractor and copies have been delivered to the Engineer.

The Contractor shall resubmit the Product Data should the Evaluation Service Report become invalid before the installation of the anchors and dowels as determined by the Engineer.

The installation, including the drilling of the holes, of the anchors and dowels with adhesive bonding material shall be performed by qualified installers. Personnel instructed and trained on the installation of the adhesive bonded anchors and dowels in accordance with the MPII by the adhesive bonding material manufacturer shall be considered qualified installers. The Contractor shall arrange for a manufacturer's

representative to provide onsite installation instruction and training for the Contractor's installation personnel and the Engineer.

Installers of horizontally oriented anchors and dowels subject to sustained tension loads as shown on the plans, shall hold current ACI Adhesive Anchor Installer Certification credentials.

The installation of all anchors and dowels with adhesive bonding material shall be inspected by an inspector, provided by the Contractor, holding current ACI Post-Installed Anchor Inspector Certification credentials. The installation of any horizontally oriented anchors and dowels subject to sustained tension load shall be continuously inspected during installation by the inspector provided by the Contractor, holding current ACI Post-Installed Anchor Inspector Certification credentials.

Prior to drilling holes for the anchors and dowels, the Contractor shall provide the following installer and inspector information to the Engineer:

1. documentation confirming that all the installers are qualified and have been trained by the adhesive bonding material manufacturer
2. a copy of each installer's ACI Adhesive Anchor Installer Certification card, as applicable
3. a copy of the inspector's ACI Post-Installed Anchor Inspector Certification card

The installation, including drilling of holes, of the anchors and dowels with adhesive bonding material shall be in accordance with the adhesive bonding material MPII. The methods and equipment used to drill and clean the holes, weather conditions at the time of installation, temperature of the concrete, anchor and dowel, and the condition of the hole at time of installation shall also be in accordance with the MPII. The use of tools, such as drill bits and cleaning brushes, from a manufacturer different from the manufacturer of the adhesive bonding material is not permitted unless noted otherwise in the adhesive bonding material MPII. In case of conflict between these specifications and the MPII, the requirements of the MPII shall govern.

The anchors and dowels shall be installed in clean, dry holes (no water present) drilled into structurally sound concrete and bonded with adhesive bonding material. Structurally sound concrete is solid when sounded with a hammer, uncracked, greater than 21 days old, and has a compressive strength no less than its design strength when it was originally placed. If the hole is filled with water, partially filled with water, or water entered the hole during drilling, the Contractor shall blow out the water using compressed air and allow a minimum of 24 hours before cleaning the hole and installing the anchors or dowels. The Contractor shall not install anchors or dowels in saturated, surface dry holes (holes with damp surfaces, but no standing water).

Holes for the anchors and dowels shall be located and drilled to a depth no less than the anchor embedment depth shown on the plans. A pachometer shall be used to locate existing reinforcing steel. If existing reinforcing is encountered during the drilling operation, the holes shall be relocated as noted on the plans. Core drilling through the reinforcing bars may be allowed if noted on the plans. Drilled holes that are abandoned shall be completely filled with adhesive bonding material or non-shrink grout and finished flush with the adjacent concrete surface.

- C. **Field Testing:** After the adhesive bonding material has fully cured in accordance the MPII, the anchors and dowels shall be field tested to verify the installation procedures and installed adhesive anchor strength. Field testing shall be performed by an independent third-party testing agency, hired by the Contractor.

The Contractor shall provide the testing agent with a copy of the plans and these provisions and instruct the testing agent to perform the following:

1. Verify the adhesive bonding material used
2. Check that the anchorage size and type match the requirements of the Contract
3. Perform all field testing in accordance with the Contract
4. Record all test results on a field proof load test report form (sample form included herein)
5. Sign and date the test form

The Contractor shall submit the completed, and signed test report form to the Engineer.

The adhesive bonded anchors and dowels to be field tested at each location shall be randomly selected by the Engineer based on the tabulated number to be tested shown on the plans. A confined static tension test shall be performed in accordance with ACI 355.4 and ASTM E488 for the proof test load shown on the plans, in the presence of the Engineer. The test equipment shall be capable of measuring displacement of the anchor or dowel. The proof test load shall be maintained for a minimum of 10 seconds. In order to pass the field test, the tested anchors and dowels shall have no visible damaged during or after the proof load, no indications of displacement at the proof test load and no cracking of concrete in the vicinity of the anchor

or dowels. An additional anchor or dowel shall be tested for each anchor or dowel that does not pass the field test.

All anchors and dowels that do not pass the field test shall be removed without any damage to surrounding concrete. The Contractor shall reinstall new anchors and dowels in accordance with the requirements described herein. Holes can be re-drilled to remove the adhesive bonding material residue prior to new anchor or dowel installation. The anchors and dowels at the failed locations shall not be reused.

- D. **Repairs:** The Contractor, as directed by the Engineer, shall take adequate precautions to prevent any materials from dropping to the area below, which may result in damage to any existing construction or to adjoining property. Should any damage occur to the structure as a result of the Contractor's operations, the Contractor shall make repairs at their expense. The repair work shall be approved in advance and shall be of a quality acceptable to the Engineer.

6.10.04 - Method of Measurement: This work will be measured for payment by the actual number of drilled holes in which anchors and dowels are embedded and accepted.

6.10.05 - Basis of Payment: This work will be paid for at the Contract unit price each for "Drilling Holes and Bonding Anchors" or "Drilling Holes and Bonding Dowels," which price shall include drilling and preparing holes, furnishing and installing adhesive bonding material, furnishing anchors and dowels, providing an ACI Certified inspector, testing of the installed anchors and dowels, and all material, equipment, tools and labor incidental thereto.

Pay Item	Pay Unit
Drilling Holes and Bonding Anchors	ea.
Drilling Holes and Bonding Dowels	ea.

Field Proof Load Test Report

CTDOT Project:		Date:	
Contractor:		Weather:	
Contractor Representative:		Temperature:	AM PM
Independent Testing Firm: <i>(Name/Address)</i>		Technician:	
		Arrival Time:	
		Departure Time:	
Location of Work: (Town/Crossing/Bridge No.)			

Item Details			
Item Tested	Size	Grade	Embedded Depth

Equipment Information			
Hydraulic Ram Number	Hydraulic Ram Capacity	Dial Gauge Number	Dial Gauge Capacity

Test Application Method:	
--------------------------	--

Required Load (lbs):		Required Dial Reading (psi):	
----------------------	--	------------------------------	--

Test Results								
Test #	Location	Dial Reading (psi)	Max Load (lbs)	Failure Type (None, Bond, Concrete, Component)	Displacement		Pass/Fail	Witnessed By
					Loaded	Unloaded		
1								
2								
3								
4								
5								
6								
7								
8								
9								
10								
11								
12								
13								
14								
15								
16								
17								
18								
19								
20								

Comments/Sketch (attach additional sheets if applicable)

Large empty rectangular area for providing comments or sketches.

***REQUIRED - Include sketch of location and details of testing**

Signature:

Date:

SECTION 6.86
DRAINAGE PIPES, DRAINAGE PIPE ENDS

Add the following after the last paragraph of Subarticle 6.86.03-3:

Material placed around pipes shall be deposited on both sides to approximately the same elevation at the same time, in accordance with 2.86.03.

**SECTION 7.07
MEMBRANE WATERPROOFING
(WOVEN GLASS FABRIC)**

Replace Section 7.07 with the following:

**SECTION 7.07
MEMBRANE WATERPROOFING
(WOVEN GLASS FABRIC)**

(Vacant)

SECTION 8.03
PAVED DITCHES, PAVED APRONS AND
PAVED CHANNELS

Replace Section 8.03 in its entirety with the following:

SECTION 8.03
PAVED APRONS

- 8.03.01—Description
- 8.03.02—Materials
- 8.03.03—Construction Methods
- 8.03.04—Method of Measurement
- 8.03.05—Basis of Payment

8.03.01—Description: The work under this item includes placing and compacting of a bituminous concrete course on a pre-excavated foundation forming paved aprons in accordance with the line, grade, compacted final thickness and typical cross-section shown on the plans.

8.03.02—Materials: The materials for this work shall meet the following requirements:
Bituminous Concrete Curb Mix shall meet the requirements of 4.06 and M.04.01.
Processed Aggregate Base shall meet the requirements of M.05.01.

8.03.03—Construction Methods: The processed aggregate base course shall be placed in a single course, 4 inches compacted thickness, in accordance with 3.04.03. The surface shall be a 2 inch course of bituminous concrete curb mix. The bituminous concrete shall be placed and thoroughly compacted with compaction equipment suitable for small areas.

8.03.04—Method of Measurement: The quantity to be measured for **this** item will be the surface area in square yards of paved apron constructed and accepted.
Formation of Subgrade and Processed Aggregate Base will not be measured for payment.

8.03.05—Basis of Payment: This work will be paid for at the Contract unit price per square yard for "Paved Apron." The price shall include all materials, tools, equipment and work incidental thereto.

Pay Item	Pay Unit
Paved Apron	s.y.

**SECTION 8.18
PROTECTIVE COMPOUND FOR BRIDGES**

Delete Section 8.18 in its entirety.

**SECTION 8.22
TEMPORARY TRAFFIC BARRIER**

Replace Section 8.22 in its entirety with the following:

**SECTION 8.22
TEMPORARY TRAFFIC BARRIER**

8.22.01—Description

8.22.02—Materials

8.22.03—Construction Methods

8.22.04—Method of Measurement

8.22.05—Basis of Payment

8.22.01—Description: Work under this item shall consist of furnishing, installing, relocating and removing temporary traffic barrier.

8.22.02—Materials: The precast concrete materials for temporary traffic barrier shall meet the requirements of Article 8.21.02 except that reinforcing steel does not need to be galvanized.

The delineator shall be fabricated of aluminum, steel, plastic, or of a material approved by the Engineer. The retroreflective sheeting shall be Type IV, Type V, or Type IX as specified in Article M.18.09. Delineator fastening hardware or adhesive shall be suitable for the purpose intended.

The connection rod and anchors shall be manufactured in accordance with AASHTO M 314, Grade 55. Threads shall be UNC Series as specified in ANSI B1.1 and shall have Class 2A threaded tolerances before galvanizing.

Plain steel washers shall be manufactured in accordance with ANSI B18.22.

Heavy hex nuts shall be Grade A, manufactured in accordance with AASHTO M 291.

Connection loop bars shall be bent from smooth bars that meet the requirements of ASTM A36.

Steel tube for the connection key shall meet the requirements of ASTM A500, Grade B or C, and shall be hot dip galvanized in accordance with ASTM A123.

Steel plate shall be AASHTO M270 Grade 36 or 50, and shall be hot dip galvanized in accordance with ASTM A123.

Adhesive bonding material shall meet the requirements of Article 6.10.02.

Non-shrink, non-staining grout shall meet the requirements of Article M.03.05.

Membrane waterproofing (cold liquid elastomeric) shall be selected from the Qualified Products List and shall be able to be applied by brush.

8.22.03—Construction Methods:

1. Submittals:

- a. When used temporary traffic barrier is furnished, the Contractor shall provide documentation in accordance with 1.06.02 demonstrating compliance with the Contract requirements.

Any temporary precast concrete barrier curb that was fabricated after March 24, 2021, that does not, at a minimum, meet AASHTO MASH (TL-3) is not allowed to be used as temporary traffic barrier. The condition of all precast concrete temporary traffic barrier must meet the “acceptable” or “marginal” definitions in the ATSSA [“Quality Guidelines for Temporary Traffic Control Devices and Features.”](#)
- b. When an alternative temporary traffic barrier is requested, the Contractor shall submit to the Engineer a Materials Certificate, in accordance with Article 1.06.07, and a copy of the Federal-aid eligibility letter issued to the manufacturer documenting that the device complies with the minimum requirements of MASH (TL-3) and does not exceed the deflection distance indicated on the plans for the type of temporary traffic barrier proposed.
- c. Submit Materials Certificates for the steel plate, connection rods, anchors and non-shrink, non-staining grout.
- d. A Materials Certificate for the membrane waterproofing (cold liquid elastomeric) shall be submitted to the Engineer, in accordance with Article 1.06.07, along with the manufacturer’s written installation instructions for application of the membrane when repair of deck membrane is required after removal of anchors.
- e. Submit Product Data for the selected adhesive bonding material, in accordance with Article

6.10.03-A.

2. **Precast Unit:** Concrete temporary traffic barrier units shall be precast in accordance with the pertinent requirements of Article 8.21.03, except the penetrating sealer protective compound need not be applied to the precast unit.

3. **Installation & Removal:** Temporary traffic barrier units shall be placed as shown on the plans or as directed by the Engineer, on a firm even surface to produce a smooth continuous length of barrier.

Any damaged material shall be removed and replaced by the Contractor at their expense. The Contractor shall maintain the condition and alignment of the temporary traffic barrier during all stages of construction.

The Contractor shall relocate the temporary traffic barrier and its appurtenances to locations within the Project limits when shown on the plans or as ordered by the Engineer. When the temporary traffic barrier is no longer required, it shall be removed completely from the Project and shall remain the property of the Contractor.

Any holes in concrete decks created for anchoring shall be filled with non-shrink, non-staining grout up to the concrete surface after barrier removal. Anchors secured to the deck using adhesive bonding material shall be cut flush with the concrete surface when no longer needed. If the temporary traffic barrier is set on a bituminous wearing surface on top of the concrete deck and the existing membrane is to remain, a six-inch diameter pavement core shall be drilled around each anchor to the top of deck to remove the wearing surface and to provide access to cut off the anchor or fill the hole in the deck. All loose or poorly adhering membrane and other materials that could adversely affect the bond of the membrane to the deck shall be removed from the concrete surface. Cold liquid elastomeric membrane shall be brush-applied to the exposed concrete surface in accordance with the accepted installation instructions submitted by the manufacturer. The minimum thickness of membrane shall be 80 mils which shall be measured using a wet film gage. After the membrane is cured in accordance with the manufacturer's written recommendations, the core hole shall be filled using a bituminous concrete mixture at a minimum temperature of 240°F containing the same or smaller nominal maximum aggregate size and compacted with a hand compactor or other mechanical means to the maximum compaction possible. The bituminous concrete shall be compacted to 1/8 inch above the finished pavement.

4. **Delineator:** The delineator shall be installed in the center on top of all barriers on the roadway and those installed within 8 feet from the edge of road, and at the locations designated on the plans. They shall be fastened by adhesive or hardware and must be maintained in good condition at all times. The color of the delineator shall match the color of the adjacent pavement marking edge line.

DE-7 (One Way White) delineators shall be used when the barriers are on the right side of traffic or dividing traffic in the same direction.

DE-7A (One Way Yellow) delineators shall be used when the barriers are on the left side of traffic.

DE-7B (Two Way Yellow) delineators shall be used when the barriers divide opposing traffic lanes.

DE-7D (Two Way White) delineators shall be used when the barriers are installed in an alternating one-way traffic operation.

Spacing of delineators on temporary traffic barriers shall be as specified on Traffic Standard Sheet TR-1205_01.

5. **Connection:** Nuts for the connection rod pin and loop connection shall be turned until the washer is drawn up against the connection loop. The connection loops must not be bent in the tightening process. For ease in removing the nuts, the threads may be waxed. Connection keys shall be installed as shown on the Plans

6. **Anchoring:** Anchoring temporary traffic barrier shall be with adhesive bonding material, thru-bolting, or pinning as shown on the plans, except only threaded inserts shall be used on new prestressed concrete members and shall be cast into the deck in locations that accommodate the stage construction. Shop drawings for the new prestressed concrete members shall reflect the use of inserts. Drilling into prestressed concrete members is not permitted. Installation of anchors with adhesive bonding material shall be in accordance with Article 6.10.03.

The terminal units of temporary barrier curb shall be 20 feet in length and shall be anchored with pins on both sides as shown on the plans.

8.22.04—Method of Measurement: This work will be measured for payment along the centerline of the top of the temporary traffic barrier and will be the actual number of linear feet of temporary traffic barrier

furnished, installed and accepted. Relocated temporary traffic barrier will be measured along the centerline of the top of the barrier each time the barrier has been satisfactorily relocated as directed by the Engineer, including to and from the storage area. Storage of barrier will not be measured for payment. Relocation of temporary traffic barrier for access to the work area, or for the convenience of the Contractor, shall be considered incidental to Maintenance and Protection of Traffic and will not be measured for payment.

The terminal units will not be measured separately. Their length will be included in the length of temporary traffic barrier installed.

Delineators will not be measured for payment.

Anchoring materials, filling of holes, cutting off adhesive bonded anchors, coring, furnishing and applying waterproofing membrane and filling in core holes with bituminous concrete will not be measured for payment.

8.22.05— Basis of Payment: This work will be paid for at the Contract unit price per linear foot for "Temporary Traffic Barrier" or "Temporary Traffic Barrier (Type)," complete in place, which price shall include all furnishing, transportation, initial installation, final removal, storage, materials, reinforcing steel, connecting rods, anchoring materials, equipment, tools and labor incidental thereto. Each temporary traffic barrier will be paid for once regardless of the number of times it is used on the Project. Any temporary traffic barrier that become lost, damaged or defaced shall be replaced by the Contractor at no cost to the State.

The relocation of the temporary traffic barrier will be paid for at the Contract unit price per linear foot for "Relocated Temporary Traffic Barrier" or "Relocated Temporary Traffic Barrier (Type)," which price shall include all transportation, installation, removal, materials, equipment, tools, storage and labor incidental thereto.

Pay Item	Pay Unit
Temporary Traffic Barrier	l.f.
Temporary Traffic Barrier (Pinned)	l.f.
Temporary Traffic Barrier (Bolted)	l.f.
Relocated Temporary Traffic Barrier	l.f.
Relocated Temporary Traffic Barrier (Pinned)	l.f.
Relocated Temporary Traffic Barrier (Bolted)	l.f.

**SECTION 9.10
METAL BEAM RAIL**

Replace Subarticle 9.10.02-1 with the following:

1. **Adhesive bonding** material shall meet the requirements of 6.10.02.

Add the following after the eighth paragraph of Article 9.10.03:

Rail attachment to concrete bridge parapets, barriers, or other fixed objects shall be made using through bolts as shown on the plans. When anchor bolts for rail attachments are shown on the plans to be installed into existing concrete, drilling and bonding shall be as specified in Article 6.10.03. A minimum of 3 anchors, or 5% of the total number of anchors, whichever is greater, shall be tested in accordance with 6.10.03-C.

Replace Subarticle 9.10.04-3 with the following:

3. (Type) Attachment: The number of rail attachments to bridge parapets, barriers or other fixed objects measured for payment will be the actual number of accepted attachments of each type or designation installed in accordance with the "Pay Limit for Attachment" shown on the plans. **Anchoring materials, and testing and inspection as specified in 6.10.03 will not be measured for payment.**

Replace Subarticle 9.10.05-3 with the following:

3. (Type) Attachment: This work will be paid for at the Contract unit price for each type of attachment furnished and installed. The price shall include all materials, drilling for attachment to concrete, either preset anchor bolts, pipe sleeves and through bolts, or anchor bolts to be bonded into drilled holes, removal and disposal of surplus material, equipment, tools, and labor incidental to the installation of the attachment.

**SECTION 9.21
CONCRETE SIDEWALKS AND RAMPS**

Replace Section 9.21 in its entirety with the following:

**SECTION 9.21
CONCRETE SIDEWALKS AND RAMPS****9.21.01—Description****9.21.02—Materials****9.21.03—Construction Methods****9.21.04—Method of Measurement****9.21.05—Basis of Payment**

9.21.01—Description: This item shall consist of concrete sidewalks and ramps constructed on a granular fill or reclaimed miscellaneous aggregate base course in the locations and to the dimensions and details shown on the plans or as ordered.

9.21.02—Materials: Materials for this work shall meet the requirements of M.03. Concrete shall have a minimum compressive strength of 4,400 psi. Liquid membrane-forming curing compound shall be as specified in M.03.04-3.

Granular fill or reclaimed miscellaneous aggregate for base shall be as specified in M.02.01.

Detectable warning [surfaces](#) shall be prefabricated detectable warning tile chosen from the Department's [Qualified Products List](#) for retrofit or cast in place applications.

9.21.03—Construction Methods:

1. Excavation: Excavation, including removal of any existing sidewalk (bituminous or concrete) and curbing, shall be made to the required depths below the finished grade, as shown on the plans or as directed. All soft and yielding material shall be removed and replaced with suitable material.

When connecting new concrete sidewalk to a section of existing concrete sidewalk, the connection point shall be at the nearest joint in the existing sidewalk.

The Contractor shall establish the limits required to achieve grades for each ramp prior to removal of existing sidewalk and ramps. The Contractor shall document and notify the Engineer of any control points that may conflict with the design grades or configuration of ramps shown on the plans. Control points can be but are not limited to ROW, utility poles, drainage structures, buildings, fences, walls or other features found near the proposed ramp. When control points are encountered within the limits of the ramp, the Engineer will determine if an alternative ramp type is required or the ramp is to be constructed as shown on the plans.

2. Granular Fill or Reclaimed Miscellaneous Aggregate Base: The granular fill or reclaimed miscellaneous aggregate base shall be placed in layers not to exceed 6 inches deep and to such a depth that after compaction it shall be at the specified depth below the finished grade of the walk. The base shall be wetted and rolled or tamped after the spreading of each layer.

3. Forms: Forms shall be of metal or wood, straight, free from warp and of sufficient strength to resist springing from the pressure of the concrete. If made of wood, they shall be of 2 inch surfaced plank except that at sharp curves thinner material may be used. If made of metal, they shall be of approved section and shall have a flat surface on the top. Forms shall be of a depth equal to the depth of the sidewalk. Forms shall be securely staked, braced and held firmly to the required line and grade and shall be sufficiently tight to prevent leakage of mortar. All forms shall be cleaned and oiled or wetted before concrete is placed against them. Sheet metal templates 1/8 inch thick, of the full depth and width of the walk, shall be spaced at intervals of 12 feet or as directed. If the concrete is placed in alternate sections, these templates shall remain in place until concrete has been placed on both sides of the template. As soon as the concrete has obtained its initial set, the templates shall be removed.

4. Discontinuities: Vertical surface discontinuities shall be 1/2 inch maximum. Vertical surface discontinuities between 1/4 inch and 1/2 inch shall be beveled with a slope not steeper than 50%. The bevel shall be applied across the entire vertical surface discontinuity.

5. Concrete: The concrete shall be proportioned, mixed, placed, etc., in accordance with the provisions of 6.01.03, except as modified herein.

6. Finishing: The surface of the concrete shall be finished with a wood float or by other approved means. The outside edges of the slab and all joints shall be edged with a 1/4 inch radius edging tool. Each slab shall be divided into 2 or more sections by forming dummy joints with a jointing tool as directed.

7. Curing: Liquid membrane-forming compound shall be applied following finishing as recommended by the manufacturer.

The Contractor shall have on the Project sufficient approved cover sheet of cotton mats for the protection of the sidewalk in case of rain or breakdown of the spray equipment. The cotton mats shall be maintained in a wet condition during the period of use, as specified in 6.01.03-II-9.

8. Backfilling and Removal of Surplus Material: The sides of the sidewalk shall be backfilled with suitable material thoroughly compacted and finished flush with the top of the sidewalk. All surplus material shall be removed and the Site left in a neat and presentable condition to the satisfaction of the Engineer.

9. Detectable Warning Surface: The detectable warning surface for new construction shall be set directly in plastic concrete and each tile shall be weighed down to prevent the tile from floating after placement in wet concrete in accordance with curing procedures. Install detectable warning surface according to the plans and the manufacturer’s specifications, or as directed by the Engineer.

The detectable warning surface for retrofit construction shall be installed according to the plans. Its installation shall meet all manufacturer’s requirements.

9.21.04—Method of Measurement: This work will be measured for payment as follows:

1. Concrete Sidewalk or Ramp: This work will be measured by the actual number of square feet of completed and accepted concrete sidewalk or ramp. Liquid membrane-forming curing compound will not be measured for payment.

2. Excavation: Excavation below the finished grade of the sidewalk or ramp, backfilling, and disposal of surplus material will not be measured for payment, but the cost shall be included in the price bid for the sidewalk or ramp. Excavation above the finished grade of the sidewalk or ramp will be measured and paid for in accordance with 2.02.

3. Granular Fill or Reclaimed Miscellaneous Aggregate Base: This work will not be measured for payment, but the cost shall be considered as included in the price bid for the sidewalk or ramp.

4. Detectable Warning Surface: For new construction (cast in place), the detectable warning surface will be measured for payment by the actual number of square feet of detectable warning surface installed and accepted.

5. Retrofit Detectable Warning Strip: For retrofit construction (surface applied), the detectable warning strip will be measured for payment by the actual number of each ramp where a detectable warning strip has been installed and accepted regardless of the number of tiles installed.

6. Construction Surveying: The establishment of control points and limits of grading will be measured in accordance with the item “Construction Surveying.”

9.21.05—Basis of Payment: Construction of a concrete sidewalk or ramp will be paid for at the Contract unit price per square foot for "Concrete Sidewalk" or "Concrete Sidewalk Ramp" complete and accepted in place, which price shall include all excavation as specified above, backfill, disposal of surplus material, curb removal and any monolithic or separately cast sidewalk curb when required for the sidewalk ramp as shown on the plans, granular fill or reclaimed miscellaneous aggregate base, curing compound, equipment, tools, materials and labor incidental thereto.

A new detectable warning surface will be paid for at the Contract unit price per square foot of “Detectable Warning Surface” installed and complete in place. This price shall include all tiles, materials, equipment, tools and labor incidental thereto.

Retrofitting the existing concrete sidewalk with a detectable warning strip will be paid for at the Contract unit price for “Retrofit Detectable Warning Strip” at each ramp where the retrofit detectable warning strip has been installed complete in place. This price will include all tiles, saw cutting concrete, adhesive, drilling holes for fasteners, materials, equipment, tools and labor incidental thereto.

The establishment of control points and limits of grading will be paid for in accordance with the item “Construction Staking.”

Pay Item	Pay Unit
Concrete Sidewalk	s.f.
Concrete Sidewalk Ramp	s.f.

	Detectable Warning Surface	s.f.
	Retrofit Detectable Warning Strip	ea.

**SECTION 9.24
CONCRETE DRIVEWAY RAMP**

Replace Section 9.24 in its entirety with the following:

**SECTION 9.24
CONCRETE DRIVEWAY RAMP**

9.24.01—Description: This item shall consist of concrete driveway ramps constructed on a granular fill base in accordance with the Contract.

9.24.02—Materials: Materials for this work shall meet the following requirements:

- 1. **Portland Cement:** Concrete shall meet the requirements of M.03 for Class PCC03340 Concrete.
- 2. **Granular Fill Base:** Granular fill shall meet the requirements of M.02.01.
- 3. **Reinforcement:** Shall meet the requirements of M.06.01.

9.24.03—Construction Methods: Construction methods shall meet the requirements of 9.21.03. The surface shall be finished and marked off as directed by the Engineer.

The Contractor shall protect the driveway ramp from damage until it is opened to traffic. The ramp shall not be opened to traffic until the attainment of a compressive strength of 3,000 psi. Any damage occurring prior to the Department opening the driveway ramp to traffic shall be repaired or replaced at the Contractor's expense.

9.24.04—Method of Measurement: This work will be measured for payment as follows:

- 1. **Concrete Driveway Ramp:** This work will be measured for payment by the actual number of cubic yards of completed and accepted concrete driveway ramps.
- 2. **Excavation:** Excavation below the finished grade of each ramp, backfilling and disposal of surplus material will not be measured for payment; but the cost shall be included in the Contract price for Concrete Driveway Ramp.

Excavation above the finished grade of each ramp will be classified and paid for in accordance with 2.02.

- 3. **Granular Fill Base:** This work will not be measured for payment, but the cost shall be included in the Contract price for Concrete Driveway Ramp.
- 4. **Reinforcement:** This material will not be measured for payment, but the cost shall be included in the Contract price for Concrete Driveway Ramp.

9.24.05—Basis of Payment: This work will be paid for at the Contract unit price per cubic yard for "Concrete Driveway Ramp," complete in place, which price shall include all excavation as specified above, backfill, disposal of surplus materials, and all materials, equipment, tools and labor incidental thereto.

Pay Item	Pay Unit
Concrete Driveway Ramp	c.y.

**SECTION 9.71
MAINTENANCE AND PROTECTION OF TRAFFIC**

Replace Section 9.71 in its entirety with the following:

**SECTION 9.71
MAINTENANCE AND PROTECTION OF TRAFFIC**

9.71.01—Description: Unless other provisions are made on the plans or in the special provisions of the Contract, the Contractor shall keep the roadway under construction open to traffic for the full length of the Project and shall provide a sufficient number of travel lanes and pedestrian passways to move that traffic ordinarily using the roadway. The travel lanes and pedestrian passways shall be drained and kept reasonably smooth and in suitable condition at all times in order to provide minimum interference to traffic consistent with the proper prosecution of the work.

Suitable ingress and egress shall be provided at all times where required, for all intersecting roads and for all abutting properties having legal access.

When a scheme for maintenance of traffic, which may include detours, is shown on the plans or described in the special provisions of the Contract, this shall govern unless an alternate scheme acceptable to the Engineer is offered by the Contractor at no additional cost. If no scheme is shown on the plans or described in the special provisions of the Contract, and the Contractor wishes to deviate from the provisions of maintaining traffic as described in this Section, the Contractor may submit and the Engineer may approve a schedule showing a proposed sequence of operations and a compatible method of maintaining traffic.

The Contractor shall provide to the Engineer the name of the person who shall be responsible for installing and maintaining all temporary traffic control devices in work zones on limited access highways. This person shall be certified as a Traffic Control Supervisor by [ATSSA](#). This certification shall be maintained and valid throughout the duration of the Contract.

9.71.03—Construction Methods: The Contractor shall furnish and erect signs legally closing the highway to traffic, as shown on the plans or directed by the Engineer, prior to commencing any work on the Project.

The Contractor shall furnish a sufficient number of signs, barricades, drums, traffic cones and delineators to forewarn traffic of the construction as shown on the traffic control plans contained within or as directed by the Engineer.

The Contractor shall also provide such safety measures, pavement markings, warning devices and signs as deemed necessary to safeguard and guide the traveling public through detours ordered by the Engineer, included in the approved scheme for maintenance of traffic, or as shown on the plans. The Contractor shall erect, maintain, move, adjust, clean, relocate and store these signs, barricades, drums, traffic cones and delineators when, where and as directed by the Engineer, and in accordance with the ATSSA "Quality Guidelines for Temporary Traffic Control Devices and Features."

The use of unauthorized or unapproved signs, barricades, drums, traffic cones or delineators will not be permitted.

All signs in any one signing pattern shall be mounted the same height above the traveled surface. The Contractor shall keep all signs in proper position, clean and legible at all times. Care shall be taken so that weeds, shrubbery, construction materials or equipment, and soil, are not allowed to obscure any sign, light, or barricade. Signs that do not apply to existing conditions shall be removed or adjusted so that the legend is not visible to approaching traffic.

The Contractor, when ordered by the Engineer, shall remove snow and take care of icy conditions on temporary, new and existing sidewalks on any part of the right-of-way within the limits of the Project. Payment for the cost thereof, will be made as extra work.

Snow removal and correction of icy conditions, other than those resulting from the Contractor's operations, on uncompleted contracts under traffic, will remain an obligation of the State or others.

Should the Contractor fail to perform any of the work required under this section, the State may perform or arrange for others to perform such work. In such cases, the State will deduct from money due or to become due the Contractor all expenses connected there with which are found to be greater than the cost to the State had the Contractor performed the specified work.

9.71.04—Method of Measurement: This item, being paid on a lump sum basis, will not be measured for payment.

9.71.05—Basis of Payment: This work will be paid for at the Contract lump sum price for "Maintenance and Protection of Traffic." This price shall include all costs for labor, **training**, equipment and services involved in the erection, maintenance, moving, adjusting, cleaning, relocating and storing of signs, barricades, drums, traffic cones and delineators furnished by the Contractor, as well as all costs of labor and equipment involved in the maintenance of traffic lanes and detours, except for pavement markings, ordered or included in the approved scheme for maintenance of traffic. **This price shall also include furnishing and services of a trained Traffic Control Supervisor for work on limited access highways.**

"Maintenance and Protection of Traffic" does not include the cost of signs, barricades, drums, traffic cones, delineators, or the furnishing and placing of materials such as borrow, gravel, crushed stone, bituminous concrete for patching and pipe. These items will be paid for at **their respective** Contract unit prices, or in the absence of applicable Contract unit prices, as extra work. If the Engineer requires the Contractor to provide facilities in excess of the requirements of the adopted scheme for maintenance and protection of traffic, the Contractor shall perform the required work, and payment for the cost thereof will be made at applicable Contract unit prices, or in the absence of applicable Contract unit prices, as extra work.

Pay Item	Pay Unit
Maintenance and Protection of Traffic	l.s.

**SECTION 9.77
TRAFFIC CONE**

Replace Section 9.77 in its entirety with the following:

**SECTION 9.77
TRAFFIC CONE**

9.77.01—Description: Under this item the Contractor shall furnish all reflectorized orange traffic cones required on the Project to meet the requirements as stated in the item "Maintenance and Protection of Traffic," as shown on the plans and as directed by the Engineer.

The Contractor shall have, available on the Project, a sufficient number of traffic cones to fulfill all the requirements as specified in the Contract and to replace those traffic cones which have become damaged.

9.77.02—Materials: Traffic cones shall be constructed of materials to a thickness to withstand impact without damage to cones or to vehicles. The traffic cones shall be of sufficient mass or have bases to which ballast may be added to assure that they will not be blown over or displaced by wind from passing vehicles. Traffic cones used at night shall be reflectorized by utilizing Retroreflective Sheeting in accordance with M.18.09.

The following documentation shall be submitted by the Contractor prior to using traffic cones on the Project:

1. For traffic cones manufactured on or before December 31, 2019 and used for the duration of their normal service life, a copy of the manufacturer’s self-certification that the traffic cones comply with the requirements of the AASHTO Manual for Assessing Safety Hardware (MASH) or the NCHRP Report 350 is required.
2. For traffic cones manufactured after December 31, 2019, a copy of the manufacturer’s self-certification that the traffic cones comply with the requirements of the 2016 edition of the AASHTO MASH is required.

9.77.04—Method of Measurement: This item will be measured for payment by the number of traffic cones used on the Project.

9.77.05—Basis of Payment: This item will be paid for at the Contract unit price each for "Traffic Cone" used on the Project. Each cone will be paid for once, regardless of the number of times it is used on the Project.

Any traffic cones that are missing, damaged or defaced so that they are not effective, as determined by the Engineer in accordance with ATSSA "Quality Guidelines for Temporary Traffic Control Devices and Features," shall be replaced by the Contractor at no cost to the State.

When the traffic cones are no longer required on the Project they shall remain the property of the Contractor.

Pay Item	Pay Unit
Traffic Cone	ea.

**SECTION 9.78
TRAFFIC DRUM**

Replace Section 9.78 in its entirety with the following:

**SECTION 9.78
TRAFFIC DRUM**

- 9.78.01—Description**
- 9.78.02—Materials**
- 9.78.03—Construction Methods**
- 9.78.04—Method of Measurement**
- 9.78.05—Basis of Payment**

9.78.01—Description: Under this item the Contractor shall furnish all traffic drums required on the Project to correspond to the traffic patterns, as indicated in the Contract for "Maintenance and Protection of Traffic," as shown on the plans and as directed by the Engineer.

9.78.02—Materials: Traffic Drums shall be manufactured plastic or rubber devices designed in accordance with the latest edition of the MUTCD. The design of the device will allow for the installation of barricade warning lights. The device shall be stabilized with the use of sandbags or other approved means.

Retroreflective Sheeting, in accordance with M.18.09, shall be used on traffic drums. Only one type sheeting shall be used on a drum and all drums furnished on a construction project shall be manufactured with the same type retroreflective sheeting.

The following documentation shall be submitted by the Contractor prior to using traffic drums on the Project:

1. For traffic drums manufactured on or before December 31, 2019 and used for the duration of their normal service life, a copy of the manufacturer’s self-certification that the traffic drums comply with the requirements of the AASHTO MASH or the NCHRP Report 350 is required.
2. For traffic drums manufactured after December 31, 2019 and used without attachments, a copy of the manufacturer’s self-certification that the traffic drums comply with the requirements of the 2016 edition of the AASHTO MASH is required.
3. For traffic drums manufactured after December 31, 2019 and used with attachments such as warning lights, a copy of the Federal-Aid Eligibility Letter issued by the FHWA to the manufacturer documenting that the traffic drums with the proposed attachments meet the crash test and evaluation criteria of the 2016 AASHTO MASH is required.

9.78.03—Construction Methods:

The Contractor shall have, available on the Project, a sufficient number of traffic drums to fulfill all the requirements, as specified in the Contract, to provide adequate traffic control during periods of unforeseen circumstances or emergencies.

Traffic drums shall be designed and installed in accordance with the plans, the MUTCD latest edition, and as directed by the Engineer.

Any traffic drum that is missing, damaged or defaced so that it is not effective, as determined by the Engineer and in accordance with ATSSA "Quality Guidelines for Temporary Traffic Control Devices and Features," shall be replaced by the Contractor.

When the traffic drums are no longer required on the Project, they shall remain the property of the Contractor.

9.78.04—Method of Measurement: This work will be measured for payment by the number of traffic drums used on the Project.

9.78.05—Basis of Payment: This item will be paid for at the Contract unit price each for "Traffic Drum" used on the Project. Each drum will be paid for once, regardless of the number of times it is used on the Project.

Pay Item	Pay Unit
Traffic Drum	ea.

SECTION 9.79
CONSTRUCTION BARRICADE

Replace Section 9.79 in its entirety with the following:

SECTION 9.79
CONSTRUCTION BARRICADE

9.79.01—Description: Under this item the Contractor shall furnish all construction barricades of the specified type required on the Project to comply with the requirements of NCHRP Report 350 (TL-3), or the AASHTO MASH, and the requirements stated in the item "Maintenance and Protection of Traffic," as shown on the plans and as directed by the Engineer.

9.79.02—Materials: Construction barricades shall consist of the following materials:

The frame shall be of polyvinyl chloride pipe meeting the requirements of ASTM D2241 for PVC 1120 or 1220, SDR 21 (pressure rating 200 psi), ASTM D3034, SDR 35 or an approved equal. All straight members shall be the color white.

Wyes, tees and elbows for joint connections shall be polyvinyl chloride of suitable size and strength for the purpose intended.

Joints shall not be glued and a 3/16 inch nylon rope (or equivalent) shall be threaded loosely through the pipe to keep sections from flying if hit by a vehicle.

Face panels used as horizontal members shall be constructed of a suitable plastic material, 0.060 inch high-impact styrene, anodized aluminum of no less than 0.025 inch thickness or a comparable substitute approved by the Engineer.

All hardware shall be in accordance with standard commercial specifications and shall be approved by the Engineer.

Alternate stripes of white and **fluorescent** orange retroreflective sheeting shall be applied to the horizontal members as shown on the plans. Only one type sheeting shall be used on a barricade and all barricades on a construction project shall be constructed with the same type of retroreflective sheeting. Retroreflective sheeting shall meet the requirements of M.18.09.

Construction barricades shall be designed and fabricated so as to prevent them from being blown over or displaced by wind. Construction barricades shall be approved by the Engineer before they are placed into service.

Materials Certificates shall be required confirming compliance with the requirements set forth in the plans and specifications for these barricades.

The following documentation shall be submitted by the Contractor prior to using barricades on the Project:

1. **For barricades manufactured on or before December 31, 2019 and used for the duration of their normal service life, a copy of the Federal-Aid Eligibility Letter issued by the FHWA to the manufacturer documenting that the barricades meet the crash test and evaluation criteria of the AASHTO MASH or of the NCHRP Report 350 is required.**
2. **For barricades manufactured after December 31, 2019, a copy of the Federal-Aid Eligibility Letter issued by the FHWA to the manufacturer documenting that the barricades meet the crash test and evaluation criteria of the 2016 AASHTO MASH is required.**

9.79.03—Construction Methods: The Contractor shall furnish a sufficient number of construction barricades required for the traffic patterns for all operations which are being undertaken concurrently. The barricades shall be constructed in a neat and workmanlike manner to the satisfaction of the Engineer.

Ineffective barricades, as determined by the Engineer and in accordance with ATSSA "Quality **Guidelines for Temporary Traffic Control Devices and Features**," shall be replaced by the Contractor at no cost to the State.

Barricades that are no longer required shall be removed from the Project and shall remain the property of the Contractor.

9.79.04—Method of Measurement: This work will be measured for payment by the number of construction barricades used on the Project.

9.79.05—Basis of Payment: This item will be paid for at the Contract unit price each for "Construction Barricade" of the type specified and used on the Project. Each barricade will be paid for once, regardless of

the number of times it is used on the Project.

Pay Item

Pay Unit

Construction Barricade (Type)

ea.

**SECTION 9.81
42 INCH TRAFFIC CONE**

Replace Section 9.81 in its entirety with the following:

**SECTION 9.81
42 INCH TRAFFIC CONE**

9.81.01—Description: This item shall consist of furnishing 42-inch retroreflective traffic cones required on the Project to meet the requirements of the traffic control plans, as stated in the item "Maintenance and Protection of Traffic," as shown on the plans or as directed by the Engineer.

The Contractor shall have available on the Project a sufficient number of traffic cones to fulfill all the requirements as specified in the Contract and to replace those which have become damaged.

9.81.02—Materials: The traffic cone shall be manufactured of 2 piece construction - cone and stabilizer base. The cone shall be constructed of impact-resistant orange plastic or rubber of a thickness able to withstand impact without damage to cones or vehicles. The bottom of the cone shall be 8 1/2 inch conical diameter tapering to the top of the cone which shall be 3 1/2 inch conical diameter. The design of the device will allow for the installation of a weighted stabilizer base. The stabilizer base shall not be round in shape. It shall have a hole in the middle to allow for quick placement over the cone. The base shall be constructed of impact-resistant black plastic or rubber ballasted to 18 lbs.

Retroreflective stripes shall be fabricated from retroreflective sheeting. All stripes shall be of one type of sheeting. Retroreflective sheeting shall be as specified in M.18.09.

The following documentation shall be submitted by the Contractor prior to using traffic cones on the Project:

1. For traffic cones manufactured on or before December 31, 2019 and used for the duration of their normal service life, a copy of the manufacturer’s self-certification that the traffic cones comply with the requirements of AASHTO MASH or NCHRP Report 350 is required.
2. For traffic cones manufactured after December 31, 2019, a copy of the manufacturer’s self-certification that the traffic cones comply with the requirements of the 2016 edition of the AASHTO MASH is required.

9.81.03—Construction Methods: The stabilizer base shall be attached to the traffic cone in accordance with the manufacturer’s instructions. The Contractor shall ensure that the devices are kept clean and bright.

9.81.04—Method of Measurement: This item will be measured for payment by the number of traffic cones used on the Project.

9.81.05—Basis of Payment: This item will be paid for at the Contract unit price for "42 Inch Traffic Cone" used on the Project. Each cone will be paid for once, regardless of the number of times it is used on the Project.

Any traffic cones that are missing, damaged or defaced so that they are not effective, as determined by the Engineer, and in accordance with ATSSA "Quality Guidelines for Temporary Traffic Control Devices and Features," shall be replaced by the Contractor at no cost to the State.

When the traffic cones are no longer required on the Project, they shall remain the property of the Contractor.

Pay Item	Pay Unit
42 Inch Traffic Cone	ea.

**SECTION 10.18
NAVIGATION LIGHT**

Delete Section 10.18 in its entirety.

**SECTION 11.12
MAGNETIC VEHICLE DETECTOR**

Delete Section 11.12 in its entirety.

**SECTION M.03
 PORTLAND CEMENT CONCRETE**

Replace Section M.03 in its entirety with the following:

**SECTION M.03
 PORTLAND AND HYDRAULIC CEMENT CONCRETE**

M.03.01—Component Materials

M.03.02—Mix Design Requirements

M.03.03—Producer Equipment and Production Requirements

M.03.04—Curing Materials

M.03.05—Non Shrink, Non Staining Grout

M.03.06—Expansive Cement for Anchoring

M.03.07—Vacant

M.03.08—Joint Materials

M.03.09—Protective Compound/Sealers

M.03.10—Formwork

M.03.01—Component Materials

1. **Coarse Aggregate:** Coarse aggregate shall meet the requirements of M.01.
2. **Fine Aggregate:** Fine aggregate shall meet the requirements of M.01.
3. **Cement:** All cement shall be provided by a mill participating in the Departments' Cement Certification program. The requirements of the Certification Program are detailed in the [Departments' Quality Assurance Program for Materials](#).

- (a) **Portland Cement (PC):** Types I, II, and III Portland cement shall meet the requirements of AASHTO M 85. Type I and Type III Portland cement shall be used only when required or expressly permitted by the Project specification or the Engineer. The use of Type I or III will require that these mixtures be submitted as Non-standard Mix Designs.
- (b) **Blended Hydraulic Cements:** Types IS, IP, IL, and IT hydraulic cements consisting of Portland Cement and supplemental cementitious materials shall meet the requirements of AASHTO M 240.
- (c) **Supplemental Cementitious Material (SCM):** Unless already qualified as a Standard Mix Design, Contractor proposed Mix Designs with partial replacement of Portland Cement (PC) by the concrete producer with an SCM, shall be submitted in writing to the Engineer for approval prior to the start of work, on a project-by-project basis. The type of material, source, and the percentage of the PC replaced shall be clearly indicated. Upon request, a Certified Test Report for the SCM shall be provided to the Engineer for use during the Mix Design review.
 1. Fly Ash: Fly ash to be used as a partial replacement for Portland cement shall meet the requirements of AASHTO M 295, either Class C or Class F, including the uniformity requirements of Table 2A. Loss on Ignition for either class of fly ash shall not exceed 4.0%. Fly ash may be used to replace up to a maximum of 20% of the required Portland cement for mixes without permeability requirements. For mixes with permeability requirements, the maximum of 20% may be exceeded. The fly ash shall be substituted on a weight basis, with a minimum of 1 lb. of fly ash for 1 lb. of Portland cement. Different classes of fly ash or the same class from different sources shall not be permitted on any single project without the written approval of the Engineer.
 2. Ground Granulated Blast Furnace Slag (GGBFS): GGBFS used as a partial replacement for Portland cement shall meet the requirements of AASHTO M 302/ASTM C989, Grade 100 or 120. As determined by the Engineer, GGBFS may be used to replace a maximum of 30% of the required Portland cement for mixes without permeability requirements. For mixes with permeability requirements, the maximum of 30% may be exceeded. The Engineer may restrict or prohibit the use of GGBFS if ambient temperatures anticipated during the placement and initial curing of the concrete are low. The GGBFS shall be substituted on a weight basis, with a minimum of 1 lb. of slag for 1 lb. of Portland cement. Different sources of GGBFS shall not be permitted on any single project without the written approval of the Engineer.

3. **Ground Glass Pozzolan (GGP):** GGP used as a partial replacement for Portland cement shall meet the requirements of ASTM C1866. Alkali-silica reactivity with aggregates contained in the mix will need to be evaluated by the concrete producer to the satisfaction of the Engineer prior to use. The Engineer may restrict or prohibit the use of GGP considering the ambient temperatures anticipated during the placement and initial curing of the concrete.

4. Water: All water used in the mixing of concrete shall be odorless and clear in appearance. Surface water may be used if not taken from shallow or muddy sources; classified as Class C or Class D on the Department of Energy and Environmental Protection (DEEP) Water Quality Classification mapping; and accommodations have been made to prevent contaminants from entering the supply to the satisfaction of the Engineer. The Engineer may request that water from any surface or ground source be tested in accordance with ASTM C1602 and ASTM D512 if the appearance or scent of the water is suspect. To be acceptable, the pH of the water must not be less than 6.0 or greater than 8.0 and Chloride Ion Concentration of the water must not exceed 250ppm. Potable water taken directly from a municipal or regional water supply may be used for mixing concrete without testing. Heating or cooling of water may be required to meet mix temperature requirements at time of placement.

5. Admixtures: All admixtures shall perform their function without injurious effects upon the concrete. If requested by the TDC, the Contractor shall present a certified statement from a recognized laboratory attesting to this requirement. A "recognized" laboratory is any cement and concrete laboratory accredited by the Cement and Concrete Reference Laboratory (CCRL). The statement shall contain results of compression tests of cylinder specimens made with concrete using the admixture(s) in proportions equal to those proposed by the Contractor. The results of at least five standard 6 inch × 12 inch cylinders of each mix design shall be listed with the results of at least five like-sized cylinders not using the admixture(s). Specimens must be made and cured in the laboratory in accordance with AASHTO T 126 and will be tested in accordance with AASHTO T 22.

- (a) **Air-Entraining Admixtures:** In the event that air entrained concrete is required, an admixture meeting the requirements of AASHTO M 154 may be used. Tests for 7 and 28 day compressive and flexural strengths and resistance to freezing and thawing are required whereas tests for bleeding, bond strength and volume change will not be required.
- (b) **Other Chemical Admixtures:** In the event that concrete properties are specified that require the use of additional admixtures, or the Contractor proposes the use of additional admixtures to facilitate placement, the admixtures shall meet the requirements of AASHTO M194M/M, including the 1 year performance data.

M.03.02—Cast-in-place (CIP) Standard Mix Design Requirements

1. Standard CTDOT Mix Designs: CIP Standard Mix Designs shall be developed in accordance with applicable sections of ACI 211 and ACI 318. The mixtures shall consistently demonstrate the properties listed in Table M.03.02-1. The CIP mixtures shall also be designed to obtain the plastic properties of Portland cement concrete as specified in Table 6.01.03-2.

Table M.03.02-1 Standard Portland and Hydraulic Cement Concrete Performance Criteria

Class ¹	Compressive Strength (psi) @ 28 days AASHTO T 22	Electrical Resistivity (Permeability) kΩ-cm @ 56 days AASHTO T 358
PCC0223Z	2200	NA
PCC0334Z	3300	NA
PCC0336Z	3300	NA
PCC0354Z	3500	NA
PCC0446Z	4400	NA
PCC04462	4400	29 minimum
PCC0556Z	5500	NA
PCC05562	5500	29 minimum
PCCXXX83 ²	XXX00	15 maximum
PCCXXX82	XXX00	29 minimum
¹ PCCXXXYZ where: PCC = Portland Cement Concrete XXX = 28-day minimum compressive strength (psi x 100) Y = Nominal Maximum Aggregate Size (U.S. Sieve No. Designation) Z = Exposure Factor (See Table M.03.02-1a)		
² When this class is paid for in a surface or structural repair concrete item, the plastic properties necessary for confined placement to ensure appropriate workability for consolidation within the forms shall be noted on the delivery ticket by the concrete supplier.		

Table M.03.02-1a Exposure Factor per Application

Exposure	Application
0 Benign	Elements not exposed to weather (buried, enclosed)
1 Moderate	Exposed Elements not in contact with salt water or deicing chemicals
2 Severe	Structural Elements in substantial and consistent contact with salt water, deicing chemicals, flowing/standing water (limited use)
3 Special	Thin Elements repaired with concrete incorporating sacrificial anodes (limited use)

Mix designs shall indicate the dosage of admixtures anticipated to provide plastic properties required in the Project specification. Plastic properties of standard mix classes of concrete in the plastic state are listed in Table 6.01.03-2.

Standard Mix Designs are required to be designed and submitted by the concrete producers, and are qualified by the Department on a standing basis. Submittal or re-qualification of these Standard Mix Designs on an annual basis is not required. Previously qualified producer-designed Standard Mixes that have a record of satisfactory performance may be used on Department projects unless there is a change in the gravimetric properties or the sources of any materials. Revisions to the Standard Mix Designs, which

include changes in component sources, can be submitted at any time to the TDC, but must be **qualified prior** to use on Department projects.

2. Non-Standard CTDOT Mix Designs: Any proposed Mix Designs that do not comply with Table M.03.02-1 are required to be submitted 15 days prior to use on a project-by-project basis and **qualified** by the TDC prior to use. The use of an approved admixture with an otherwise **qualified** Standard Mix Design is not considered non-standard.

M.03.03—Producer Equipment and Production Requirements

1. General Requirements: The source of the concrete must be **qualified** by the Engineer prior to use on Department projects. Specifically, the location and capacity of the central mix or dry batch plant, and complement of truck mixers/haulers, shall be adequate for continuous placement of concrete on a typical Department project. **Qualification** may be revoked at any time in accordance with 1.06.01.

- (a) **Inspection:** The production facility supplying hydraulic cement concrete **must** have a current Certification of Ready Mixed Concrete Production Facilities from the National Ready Mixed Concrete Association (NRMCA), or equivalent certification **acceptable** to the Engineer.
- (b) In addition to the requirements of third party certification, the facility shall produce batch tickets that meet the requirements of **6.01.03-II-3(a)** for each delivery to Department projects.
- (c) **Quality Control:** The Contractor is responsible for all aspects of Quality Control (QC). As determined by the Engineer, should material delivered to a project not meet specification, the Contractor may be required to submit to the Engineer a corrective procedure for approval within 3 calendar days. The procedure shall address any minor adjustments or corrections made to the equipment or procedures at the facility.
- (d) **Suspension:** As determined by the Engineer, repeated or frequent delivery of deficient material to a Department project may be grounds for suspension of that source of material. A detailed QC plan that describes all QC policies and procedures for that facility may be required to formally address quality issues. This plan must be **demonstrated to the satisfaction** of the Engineer and fully implemented, prior to reinstatement of that facility.

2. Hand Mixed Concrete: Hand mixing shall be permitted only with the permission of the Engineer. Hand mixed batches shall not exceed 1/2 c.y. in volume. Hand mixing will not be permitted for concrete to be placed under water.

M.03.04—Curing Materials

1. Water: Any water source deemed acceptable by the Engineer for mixing concrete may be used to provide water for curing purposes. Surface water may be used if classified as Class C or Class D on the Department of Energy and Environmental Protection (DEEP) Water Quality Classification mapping and accommodations have been made to prevent contaminants from entering the supply to the satisfaction of the Engineer. In general, water shall not be taken from shallow or muddy sources. In cases where sources of supply are relatively shallow, the intake pipe shall be enclosed to exclude silt, mud, grass, etc.; and the water in the enclosure shall be maintained at a depth of not less than 2 feet under the intake pipe.

2. Mats: Mats for curing concrete shall be capable of maintaining moisture uniformly on the surface of the concrete. The mats shall not contain any materials such as dyes, sugar, etc., that may be injurious to the concrete.

The length or width of the mats shall be sufficient to cover all concrete surfaces being cured. Should more than one mat be required, sufficient overlap shall be provided by the Contractor as determined by the Engineer.

3. Liquid Membrane-Forming Compound: Liquid membrane-forming compound shall meet the requirements of AASHTO M 148 Type 2, Class B, or shall be a water-soluble linseed oil-based compound meeting the requirements of AASHTO M 148, Type 2.

4. White Polyethylene Sheeting (Film): White polyethylene sheeting (film) shall meet the requirements of AASHTO M 171.

M.03.05—Non Shrink, Non Staining Grout

1. Bagged (pre-mixed): Bagged (pre-mixed) formulations of non-shrink grout shall meet the requirements of ASTM C1107. The grout shall be mixed with potable water for use. The grout shall be mixed to a flowable consistency as determined by ASTM C230. All bagged material shall be clearly marked with the manufacturer's name, date of production, batch number, and written instructions for proper mixing, placement and curing of the product.

2. Bulk: The Contractor may formulate and design a grout mix for use on the Project in lieu of using a pre-bagged product. The Contractor shall obtain prior written approval of the Engineer for any such proposed Mix Design. Any such Mix Design shall include the proportions of hydraulic cement, potable water, fine aggregates, expansive agent, and any other necessary additive or admixture. This material shall meet all of the same chemical and physical requirements as shall the pre-bagged grout, in accordance with ASTM C1107.

M.03.06—Expansive Cement for Anchoring

The premixed anchoring cement shall be non-metallic, concrete gray in color and prepackaged. The mix shall consist of hydraulic cement, fine aggregate, expansive admixtures and water meeting the following requirements:

1. The anchoring cement shall have a minimum 24 hour compressive strength of 2,600 psi when tested in accordance with ASTM C109.

2. The water content of the anchoring cement shall be as recommended by the manufacturer. Water shall meet the requirements of M.03.01-4.

The Contractor shall provide a Certified Test Report and Materials Certificate for the premixed anchoring cement in accordance with 1.06.07 or 1.20-1.06.07. The Contractor shall also provide, when requested by the Engineer, samples of the premixed anchoring cement for testing and approval.

M.03.07—Vacant

M.03.08—Joint Materials

1. Transverse Joints for Concrete Pavement: Transverse joints shall consist of corrosion resistant load transfer devices, poured joint seal and in the case of expansion joints, expansion joint filler, all meeting the following requirements:

- (a) The corrosion resistant load transfer device shall be coated steel or sleeved steel or be made of corrosion resistant material. The dimensions of any devices used shall be as shown on the plans, exclusive of any coating or sleeving. Coated or sleeved metallic devices shall be made of steel that meets or exceeds the requirements of AASHTO M 255 Grade 75. Nonmetallic devices shall meet the strength requirements applicable to metallic devices.
- (b) All load transfer devices shall be galvanized and shall meet the requirements of M.06.01. The use of field applied bond breakers will not be permitted.
- (c) The basis of acceptance for corrosion resistant load transfer devices shall be the submission of Certified Test Reports meeting the requirements of 1.06.07 or 1.20-1.06.07 demonstrating that the load transfer device meets these requirements. The Engineer reserves the right to reject any load transfer device deemed unsatisfactory for use.

2. Longitudinal Joint Devices for Concrete Pavement: The metal used in the fabrication of longitudinal joint devices shall meet ASTM requirements for each type of metal used. The dimensions shall be as shown on the plans.

3. Joint Filler for Concrete Sidewalks and Curbing: Expansion joint filler shall be either preformed expansion joint filler or preformed rubber as indicated on the plans and shall meet the following requirements:

- (a) Preformed expansion joint filler shall be a resilient bituminous cellular type that meets the physical requirements of AASHTO M 213 and the testing requirements of ASTM D545.
- (b) Preformed rubber joint filler shall be semi-rigid, non-extruding, resilient type, closed-cell polypropylene foam meeting the requirements of ASTM D8139.

Dimensions shall be as specified or shown on the plans; and tolerances of plus 1/16 inch thickness, plus 1/8 inch depth and plus 1/4 inch length will be permitted.

4. Expansion Joint Fillers for Bridges and Bridge Bearings:

- (a) Preformed expansion joint filler for bridges shall meet the requirements of AASHTO M 153, Type I or Type II.
- (b) Pre-molded expansion joint filler for bridge bearings shall meet the requirements of AASHTO M 33.

5. Joint Sealants:

- (a) **Joint Sealer for Pavement:** The joint sealer for pavement shall be a rubber compound of the hot-poured type and shall meet the requirements of ASTM D6690 unless otherwise noted on the plans or in the special provisions.
- (b) **Joint Sealer for Structures:** Structure joint sealers shall be one of the following type sealants:

1. Where "Joint Seal" is specified on the plans, it shall meet the requirements of [ASTM C920 Type S \(Single Component\)](#), [Grade P \(Pourable, Self-leveling\)](#), or [Grade NS \(Non-sag type\)](#), [Class 50](#), or [other approved single component polyurethane-base elastomeric sealant](#).

A Certified Test Report will be required in accordance with [1.06.07](#) or [1.20-1.06.07](#).

2. Where "Silicone Joint Sealant" is specified on the plans, it shall be one of the following [sealants manufactured by the Dow Corning Corporation](#), or an approved equal:
 - i. [DOWSIL 888 Silicone Joint Sealant](#)
 - ii. [DOWSIL 890-SL Self-Leveling Silicone Joint Sealant](#)

6. Closed Cell Elastomer: The closed cell elastomer shall meet the requirements of [ASTM D1056, Grade 2B2](#). The elastomer shall have a pressure-sensitive adhesive backing on one side.

The Contractor shall deliver the closed cell elastomer to the job site a minimum of 30 days prior to installation. Prior to the delivery of the closed cell elastomer, the Contractor shall notify the Engineer of the date of shipment and the expected date of delivery. Upon delivery of the closed cell elastomer to the job site, the Contractor shall immediately notify the Engineer.

Each separate length, roll or container shall be clearly tagged or marked with the manufacturer's name, trademark and lot number. A lot is defined as that amount of closed cell elastomer manufactured at 1 time from 1 batch of elastomer. A batch is defined as that amount of elastomer prepared and compounded at 1 time. The Contractor shall furnish a Certified Test Report in accordance with [1.06.07](#) or [1.20-1.06.07](#).

[If requested by the DMT](#), the Contractor shall furnish a 1 foot length of closed cell elastomer in each lot for purposes of inspection and testing by the Engineer.

M.03.09—Protective Compound/Sealers

The brand and type of material must be listed on the Department's [Qualified Products List](#) and approved by the Engineer for the specified use.

M.03.10—Formwork

1. Stay-in-place Forms: Material for stay-in-place metal forms shall be made of zinc-coated (galvanized) steel sheet meeting [ASTM A653 \(Structural Steel \(SS\) Grade 33 through 80\)](#). The minimum thickness shall be 20 gauge. Coating weight shall meet the requirements of [ASTM A924, Class G235](#), and shall otherwise meet all requirements relevant to steel stay-in-place metal forms and the placing of concrete as specified herein and as noted in the Contract.

Form supports shall either be fabricated and meet the same material requirements as the forms, or be fabricated from structural steel meeting the requirements of [ASTM A36](#) and shall be hot-dip galvanized in accordance with [ASTM A123](#).

Lightweight filler material for forms shall be as recommended by the form manufacturer.

2. Temporary Forms and Falsework: Forms and Falsework shall be of wood, steel or other material approved by the Engineer. This approval does not relieve the Contractor from employing adequately sized materials of sufficient rigidity to prevent objectionable distortion of the formed concrete surfaces caused by pressure of the plastic concrete and other loads incidental to the construction operations.

SECTION M.04
BITUMINOUS CONCRETE MATERIALS

Replace Article M.04.01 up to Article M.04.01-1 with the following:

M.04.01—Bituminous Concrete Materials and Facilities: Each source of asphalt binder, emulsion, aggregate, and production facility used to manufacture bituminous concrete mixture, and laboratory testing the mixture must be qualified on an annual basis by the Engineer.

The basis of qualification for asphalt binder sources is participation in the National Transportation Product Evaluation Program (NTPEP), Asphalt Binder Suppliers (ABS) program and review of the sources' Quality System Manual and on-site audit report from NTPEP by the Department. In addition, each source must submit monthly split samples to the Division of Materials Testing (DMT) for each grade of binder currently or potentially supplied to Department projects.

The basis of qualification for emulsion sources is the submittal of a "Quality Control Plan for Emulsified Asphalt" formatted in accordance with AASHTO R 77 to the Engineer for review. In addition, a split sample per grade must be submitted to the DMT on a monthly basis.

The basis of qualification for aggregates is indicated in M.01

The basis of qualification for production facilities is indicated in M.04.01-10.

The basis of testing laboratory qualification for mixture testing is all testing equipment, supplies, and safety equipment shall be capable of performing all the applicable tests in their entirety that are referenced in AASHTO R 35 and AASHTO M 323 and requirements indicated in M.04.01-11

AASHTO/ASTM Standards noted with an (M) have been modified and are detailed in Table M.04.03-5.

Aggregates from multiple sources of supply must not be blended or stored in the same stockpile.

Replace Subarticle M.04.01-4 with the following:

4. Performance Graded (PG) Asphalt Binder:

(a) General:

- iii. PG asphalt binder shall be uniformly mixed and blended and be free of contaminants such as fuel oils and other solvents. Binder shall be properly heated and stored to prevent damage or separation.
- iv. The binder shall meet the requirements of AASHTO M 332 and shall be graded or verified in accordance with AASHTO R 29. The Contractor shall submit a Certified Test Report and bill of lading representing each delivery in accordance with AASHTO R 26(M). The Certified Test Report must also indicate the binder specific gravity at 77°F; rotational viscosity at 275°F and 329°F; and the mixing and compaction viscosity-temperature chart for each shipment.
- v. The Contractor shall submit the name(s) of personnel responsible for receipt, inspection, and record keeping of PG binder. Contractor Plant personnel shall document specific storage tank(s) where binder will be transferred and stored until used and provide binder samples from the storage tank to the Engineer upon request. The person(s) shall assure that each shipment is accompanied by a statement certifying that the transport vehicle was inspected before loading was found acceptable for the material shipped and that the binder is free of contamination from any residual material, along with 2 copies of the bill of lading.
- vi. The blending or combining of PG binders in one storage tank at the Plant from different suppliers, grades, or additive percentages is prohibited.

(b) Standard Performance Grade (PG) Binder:

- i. Standard PG binder shall be defined as "Neat." Neat PG binders shall be free from modification with: fillers, extenders, reinforcing agents, adhesion promoters, thermoplastic polymers, acid modification and other additives such as re-refined motor oil, and shall indicate such information on each bill of lading and Certified Test Report.
- ii. The standard asphalt binder shall be PG 64S-22.

(c) Modified Performance Grade (PG) Binder: The modified asphalt binder shall be Performance Grade PG 64E-22 asphalt modified solely with a Styrene-Butadiene-Styrene (SBS) polymer. The polymer modifier shall be added at either the refinery or terminal and delivered to the bituminous concrete production facility as homogenous blend. The stability of the modified binder shall be verified in accordance with ASTM D7173 using the Dynamic Shear Rheometer (DSR). The DSR

$G^*/\sin(\delta)$ results from the top and bottom sections of the ASTM D7173 test shall not differ by more than 10%. The results of ASTM D7173 shall be included on the Certified Test Report. The binder shall meet the requirements of AASHTO M 332 (including Appendix X1) and AASHTO R 29.

(d) Warm Mix Additive or Technology:

- i. The warm mix additive or technology must be listed on the North East Asphalt User Producer Group (NEAUPG) Qualified Warm Mix Asphalt (WMA) Technologies List at the time of bid, which may be accessed online at <http://www.neaupg.uconn.edu>.
- ii. The warm mix additive shall be blended with the asphalt binder in accordance with the manufacturer's recommendations.
- iii. The blended binder shall meet the requirements of AASHTO M 332 and shall be graded or verified in accordance with AASHTO R 29 for the specified binder grade. The Contractor shall submit a Certified Test Report showing the results of the testing demonstrating the binder grade. In addition, it must include the grade of the virgin binder, the brand name of the warm mix additive, the manufacturer's suggested rate for the WMA additive, the water injection rate (when applicable), and the WMA Technology manufacturer's recommended mixing and compaction temperature ranges.

Replace Subarticle M.04.01-9 with the following:

9. Recycled Asphalt Shingles (RAS): RAS shall consist of processed asphalt roofing shingles from post-consumer asphalt shingles or from manufactured shingle waste. The RAS under consideration for use in bituminous concrete mixtures must be certified as being asbestos-free and shall be entirely free of whole, intact nails. The RAS shall meet the requirements of AASHTO MP 23.

RAS shall be tested to determine the asphalt content and the gradation at a frequency acceptable to the Engineer. RAS stockpiles shall be maintained to prevent contamination.

The Contractor shall submit a Material Certificate to the Engineer stating that the RAS complies with all the applicable requirements.

After Subarticle M.04.01-10(h), revise with the following:

11. Testing Laboratory: The laboratory shall be provided with functioning equipment and adequate supplies to test bituminous concrete mixtures during production. The laboratory shall have a minimum of 300 s.f., have a potable water source and drainage in accordance with the CT Department of Public Health Drinking Water Division. The laboratory shall have a PC with high speed internet connection to submit electronic test results to the Engineer.

The laboratory shall be equipped with a heating system capable of maintaining a minimum temperature of 65°F. It shall be clean and free of all materials and equipment not associated with the laboratory. Sufficient light and ventilation must be provided. During summer months adequate cooling or ventilation must be provided so the indoor air temperature shall not exceed the ambient outdoor temperature.

The laboratory shall maintain a list of equipment used in the acceptance testing processes including, but not limited to, balances, scales, manometer/vacuum gauge, thermometers, and gyratory compactor, clearly showing calibration and/or inspection dates, in accordance with AASHTO R 18.

Replace the second and third paragraphs of Subarticle M.04.02-2(a) with the following:

All aggregate component consensus properties and tensile strength ratio (TSR) specimens shall be tested at an AASHTO accredited laboratory AASHTO re:source by NETTCP Certified Technicians.

All bituminous concrete mixes shall be tested for stripping susceptibility by performing the TSR test procedure in accordance with AASHTO T 283(M) at a minimum every 36 months. The compacted specimens may be fabricated at the Plant and then tested at an AASHTO re:source accredited facility.

Replace the first paragraph Subarticle M.04.02-2(c) with the following:

(c) **Mix Status:** Each facility will have each type of bituminous concrete mixture rated based on the results of the previous year of production. Mix status will be **developed for** each bituminous concrete facility prior to the beginning of the paving season.

After “A” – Approved: in Subarticle M.04.02-2(c) add the following:

“U” – Not Approved: Status assigned to a type of mixture that does not have an approved JMF. Bituminous concrete mixtures with a “U” status cannot be used on Department projects.

Replace the Subarticle M.04.02-2(c)(1) with the following:

1. no compliant acceptance production test results **have been** submitted to the Department from the previous year;

Replace the paragraph after Subarticle M.04.02-2(c)(7) with the following:

Bituminous concrete mixtures rated with a “PPT” status cannot be used on Department projects **until modifications are made at the facility**. Sufficient testing by NETTCP certified personnel must confirm that specification requirements in Tables M.04.02-2 through M.04.02-4 are met and the binder content (Pb) meets the requirements in Table M.04.03-2 before material can be used. One of the following methods must be used to verify the test results:

Replace the paragraph after Option C: in Subarticle M.04.02(c) with the following:

Department Witness or verification of compliant test results will change the mix’s status to “A” The differences between the Department’s test results and the Contractor’s must be within the “C” tolerances included in the [Department’s QA Program for Materials](#) in order to be verified.

Replace Subarticle M.04.03-2(a) with the following:

2. Acceptance Requirements:

(a) General:

For those mixes with a total estimated project tonnage over 500 tons, a Contractor representative shall obtain a field sample of the material placed at the project site in accordance with AASHTO R 97 or an alternate procedure approved by the Engineer. Sampling from the truck at the Plant in accordance with AASHTO R 97 will be allowed for those mixes with a total estimated project tonnage equal to or less than 500 tons. **The Contractor’s representative obtaining mix samples must be a certified NETTCP HMA Paving Inspector, NETTCP HMA Plant Technician, or has successfully completed the HMA Field Sampling Course administered by the Connecticut Advanced Pavement Laboratory.** Regardless of sampling location, the sample shall be quartered by the Contractor in accordance with AASHTO R 47 and placed in an approved container. **For samples obtained at the project site, a Type A Mechanical Splitter shall be used to quarter the sample in accordance with AASHTO R 47.** The container shall be sealed with a security tape provided by the Department and labelled to include the project number, date of paving, mix type, lot and subplot numbers and daily tonnage. The minimum weight of each quartered sample shall be 14000 grams. The Contractor shall transport one of the containers to the Departments Central Laboratory in Rocky Hill, retain one of the sealed containers for potential use in dispute resolution and test the remaining samples for acceptance in accordance with past practice.

The Contractor shall submit all acceptance tests results to the Engineer within 24 hours or prior to the next day’s production. All acceptance test specimens and supporting documentation must be retained by the Contractor and may be disposed of with the approval of the Engineer. All quality control specimens shall be clearly labeled and separated from the acceptance specimens.

Contractor personnel performing QC and acceptance testing must be present at the facility prior to, during,

and until completion of production, and be certified as a NETTCP HMA Plant Technician and be in good standing. Production of material for use on State projects must be suspended by the Contractor if such personnel are not present. Technicians found by the Engineer to be non-compliant with NETTCP policies and procedures or Department policies may be removed by the Engineer from participating in the acceptance testing process for Department projects until their actions can be reviewed.

Verification and dispute resolution testing will be performed by the Engineer in accordance with the Department's QA Program for Materials.

Should the Department be unable to validate the Contractor's acceptance test result(s) for a lot of material, the Engineer will use results from verification testing and re-calculate the pay adjustment for that lot. The Contractor may request to initiate the dispute resolution process in writing within 24 hours of receiving the adjustment and must include supporting documentation or test results to justify the request.

Replace Table M.04.03-1 with the following:

TABLE M.04.03-1: Curb Mix Acceptance Test Procedures

Protocol	Reference	Description
1	AASHTO T 30(M)	Mechanical Analysis of Extracted Aggregate
2	AASHTO R 97	Sampling of Bituminous Concrete
3	AASHTO T 308	Binder Content by Ignition Oven Method (adjusted for aggregate correction factor)
4	AASHTO T 209(M) ⁽²⁾	Theoretical Maximum Specific Gravity and Density of Bituminous Paving Mixtures
5	AASHTO T 312 ⁽²⁾	⁽¹⁾ Superpave Gyratory Molds Compacted to N _{des}
6	AASHTO T 329	Moisture Content of Hot-Mix Asphalt (HMA) by Oven Method

Replace Table M.04.03-2 with the following:

**TABLE M.04.03-2:
Superpave Acceptance Testing Frequency per Type/Level/Plant for Non-PWL Lots**

Daily Quantity Produced in Tons (Lot)	Number of Sub Lots/Tests
0 to 125	0, Unless requested by the Engineer
126 to 500	1
501 to 1,000	2
1,001 to 1,500	3
1,501 or greater	1 per 500 tons or portions thereof

Replace Table M.04.03-3 with the following:

TABLE M.04.03-3: Superpave Acceptance Testing Procedures

Protocol	Procedure	Description
1	AASHTO R 97	Sampling of bituminous concrete
2	AASHTO R 47	Reducing samples to testing size
3	AASHTO T 308	Binder content by ignition oven method (adjusted for aggregate correction factor)
4	AASHTO T 30(M)	Gradation of extracted aggregate for bituminous concrete mixture
5	AASHTO T 312	⁽¹⁾ Superpave gyratory molds compacted to N_{des}
6	AASHTO T 166	⁽²⁾ Bulk specific gravity of bituminous concrete
7	AASHTO R 35	⁽²⁾ Air voids, VMA
8	AASHTO T 209(M)	Maximum specific gravity of bituminous concrete (average of 2 tests)
9	AASHTO T 329	Moisture content of bituminous concrete

Replace the second paragraph after Table M.04.03-3 in Subarticle M.04.01-2(c) with the following:

The Contractor shall perform TSR testing within 30 days after the start of production for all design levels of HMA- and PMA- S0.5 Plant-produced mixtures, in accordance with AASHTO T 283(M). The TSR test shall be performed at an **AASHTO re:source** certified laboratory by NETTCP certified technicians. The compacted specimens may be fabricated at the Plant and then tested at an **AASHTO re:source** accredited facility.

Replace Subarticle M.04.03-2(c)(iii) with the following:

i. **JMF revisions:**

JMF revisions are only permitted prior to or after a production shift. A JMF revision is effective from the time it was submitted and is not retroactive to the previous test(s).

JMF revisions shall be justified by a documented trend of test results.

Revisions to aggregate or RAP specific gravities are only permitted when testing is performed at an **AASHTO re:source** certified laboratory by NETTCP certified technicians.

A JMF revision is required when the Plant target RAP or bin percentage deviates by more than 5% or the Plant target binder content deviates by more than 0.15% from the active JMF.

Replace Table M.04.03-5 with the following:

**Table M.04.03-5:
Modifications to Standard AASHTO and ASTM Test Specifications and Procedures**

AASHTO Standard Method of Test	
Reference	Modification
T 30	Section 7.2 through 7.4 Samples are not routinely washed for production testing
T 209	Section 7.2 The average of 2 bowls is used proportionally in order to satisfy minimum mass requirements. 8.3 Omit Pycnometer method.
T 283	When foaming technology is used, the material used for the fabrication of the specimens shall be cooled to room temperature, and then reheated to the manufacturer’s recommended compaction temperature prior to fabrication of the specimens.
AASHTO Standard Recommended Practices	
Reference	Modification
R 26	<p>All laboratory technician(s) responsible for testing PG binders shall be certified or Interim Qualified by NETTCP as a PG Asphalt Binder Lab Technician.</p> <p>All laboratories testing binders for the Department are required to be accredited by AASHTO re:source.</p> <p>Sources interested in being approved to supply PG binders to the Department by use of an “in-line blending system” must record properties of blended material and additives used.</p> <p>Each source of supply of PG binder must indicate that the binders contain no additives used to modify or enhance their performance properties. Binders that are manufactured using additives, modifiers, extenders, etc., shall disclose the type of additive, percentage and any handling specifications or limitations required.</p> <p>All AASHTO M 320 references shall be replaced with AASHTO M 332.</p> <p>Once a month, 1 split sample and test results for each asphalt binder grade and each lot shall be submitted by the PG binder supplier to the Department’s Central Lab.</p> <p>Material remaining in a certified lot shall be re-certified no later than 30 days after initial certification. Each April and September, the PG binder supplier shall submit test results for 2 BBR tests at 2 different temperatures in accordance with AASHTO R 29.</p>

**SECTION M.06
METALS**

Replace Article M.06.03 with the following:

M.06.03—Galvanizing: Unless otherwise specified on the plans or in the special provisions, the zinc coating on all iron and steel materials, other than wire, shall meet the requirements of ASTM A123, A153 or F2329, whichever shall apply.

The use of aerosol galvanizing products is strictly prohibited. This applies to both shop and field touch ups or repairs.

When mechanical galvanizing is used it shall meet the requirements of ASTM B695 Class 55.

**SECTION M.07
PAINT**

Replace Section M.07 in its entirety with the following:

**SECTION M.07
PAINT**

M.07.01—General for All Paints and Enamels

M.07.02—Coating Systems for Structural Steel

M.07.03 through M.07.19 —Vacant

M.07.20—Waterborne Pavement Marking Paint

M.07.21—Hot-Applied Waterborne Pavement Marking Paint

M.07.22—Epoxy Resin Pavement Markings

M.07.23—Vacant

M.07.24—Preformed Black Line Mask Pavement Marking Tape

M.07.25—Vacant

M.07.30—Glass Beads

M.07.01—General for All Paints and Enamels:

1. Paints and enamels shall consist of pigments of the required fineness and composition, ground in the required vehicle by a suitable grinding machine to the required fineness. All pigments, resins, oils, thinners and driers shall be free from adulterants.

2. Proportions: All proportions in formulas are by weight unless otherwise specified.

3. Fineness: All pigments, except aluminum, unless otherwise specified, shall be finely ground with 100% passing the No. 200 sieve; with no less than 97% passing the No. 325 sieve.

4. Curdling, Livering, Leveling: The paint or enamel shall not liver or curdle. The pigment shall remain in suspension in a satisfactory manner through the expected shelf life specified on the label. The enamel type paints shall level properly and not show brush marks.

5. Colors: All paints and enamels shall be matched to the Department's standard shades.

6. Time of Drying: All paints or enamels, unless otherwise specified, shall dry to full gloss in not more than 18 hours.

7. Weight per Gallon: The weight per gallon of all paints and enamels shall be determined at 77°F.

8. Shipping: All paints and enamels shall be shipped in containers plainly marked with the name, net weight and volume of paint or enamel content. The manufacturer's name, address, date and lot number shall be marked on every package.

9. Samples, Sampling, and Testing: The manufacturer shall supply a Certified Test Report per lot for any pigment, oil, resin, thinner, drier or paint. When a portion of the lot is delivered, a Material Certificate is required. Upon request by the Engineer, the manufacturer shall submit a sample in accordance with the latest edition of the Materials Testing Manual's "[Minimum Schedule for Acceptance Testing](#)."

Sampling and testing shall be performed in accordance with ASTM, Federal Standards, or by methods established by the Department.

M.07.02—Coating Systems for Structural Steel: The coating system used shall be specified in the Contract and shall be selected from the [Northeast Protective Coating Committee's](#) (NEPCOAT's) Specification Criteria for Protective Coatings qualified products list.

Color: The color of the topcoat material shall be as noted on the plans (**AMS-STD-595** Color Number).

Packaging and Labeling of Coating Material: The container shall be designed to store the specific coating material. Each container of coating material shall bear a label that identifies the name of the coating manufacturer, the name of the product, the lot and batch numbers, the date of manufacture and the shelf life expiration date. The label shall also include complete specific instructions for opening the container and for mixing, thinning, and applying the coating material contained therein. If the coating material cannot be positively identified from the label on the container, it shall not be used.

Delivery: Coating material shall be furnished in the manufacturer's original sealed and undamaged container.

Control of Materials: For each coating material, a Materials Certificate shall be submitted in conformance

with 1.06.07 or 1.20-1.06.07. The Material Certificate shall indicate compliance with NEPCOAT Acceptance Criteria for Protective Coatings, List A or B.

M.07.03 through M.07.19—Vacant

M.07.20—Waterborne Pavement-Marking Paint: Pavement-marking paint shall be waterborne paint and shall be white or yellow, depending on its use, for application on bituminous concrete and Portland cement concrete pavement. This paint shall be compatible with the stripe-painting equipment to be used on the Project. All requirements shall be as specified in M.07.21, except as follows:

1. Total nonvolatile compounds shall not be less than 70% by weight.
2. Pigment shall be 50 to 60% by weight.
3. Drying time for no-pick-up shall be 15 minutes or less when tested in accordance with ASTM D711.
4. The Contractor shall provide a Materials Certificate in accordance with 1.06.07 or 1.20-1.06.07 for each portion of a batch or lot delivered to the Project site.

M.07.21—Hot-Applied Waterborne Pavement-Marking Paint: Fast-drying waterborne pavement-marking paint to be applied on bituminous concrete and Portland cement concrete pavements shall be the color specified on the plans. This paint shall be capable of being applied with stripe-painting equipment at an application temperature of 130 to 145°F and shall have good spraying characteristics. The Contractor shall provide a Materials Certificate in accordance with 1.06.07 or 1.20-1.06.07 for each portion of a batch or lot delivered to the Project site.

General: Specifications and publications that apply are as follows:

- FS TT-P-1952 - Paint, Traffic and Air Field Marking, Waterborne
- Federal Test Method Standard (FTMS) No.141 - Paint, Varnish, Lacquer and Related Materials, Methods of Inspection, Sampling and Testing
- **The MUTCD**

ASTM Standards:

- D211 - Specifications for Chrome Yellow and Chrome Orange Pigments
- D476 - Classification for Dry Pigmentary for Titanium Dioxide Pigments

Detailed Requirements, Formulation and Manufacture: The paint shall be formulated and manufactured from first-grade raw materials and shall be free from defects and imperfections. The materials shall not exhibit settling or jellying after storage in the sealed containers upon receipt. The paint shall provide the proper anchorage, refraction and reflection for the finished glass spheres when applied as specified.

Composition: The composition of the paint material shall meet the requirements of any applicable Federal, State or Local regulation for products of this type and shall meet the following requirements:

1. Paint shall not contain more than 0.06% lead when tested in accordance with ASTM D3335
2. Total nonvolatile organic compounds shall be a minimum of 76% by weight
3. Pigment shall be 58 to 63% by weight when tested in accordance with ASTM D3723
4. Resin solids shall be composed of 100% acrylic emulsion polymer
5. Volatile organic compounds shall not exceed 1.25 lb./gal. excluding water when tested in accordance with ASTM D2369
6. Flash Point: Closed-cup flash point shall not be less than 145°F
7. Density: Weight per gallon shall not be less than 12.5 lb./gal. when tested in accordance with ASTM D1475

Viscosity: The consistency of the paint shall not be less than 80, nor more than 90 Krebs units when tested in accordance with ASTM D562.

Flexibility: The paint shall not show cracking or flaking when tested in accordance with ASTM D522. The panels shall be lightly buffed with steel wool and thoroughly cleaned with solvent before being used for tests.

Dry Opacity: Both white and yellow paints shall have a minimum contrast ratio of 0.96 when tested in accordance with ASTM D2805. Contrast ratio shall be determined by applying a wet film thickness of 0.005 inch to a standard hiding-power chart. After drying, the black- and- white-reflectance values shall be determined using a suitable reflectometer and the contrast ratio determined.

Bleeding: The paints shall have a minimum bleeding ratio of 0.97 when tested in accordance with FS TT-P-1952.

Abrasion Resistance: No less than 210 liters of sand shall be required to remove paint film when tested in accordance with FS TT-P-1952.

Color: The paint shall not discolor in sunlight and shall maintain colorfastness throughout its life. Color determination shall be made without beads, after a minimum of 24 hours. **Paint color shall be in accordance with the MUTCD.**

Glass Bead Adhesion: The paint with glass beads conforming to M.07.30, applied at the rate of 6.0 lb./gal. of paint, shall require not less than 150 liters of sand to remove paint film and glass beads.

Scrub Resistance: The paint shall pass 300 cycles minimum when tested in accordance with ASTM D2486.

Drying Time: Drying time to no pick-up shall be 3 minutes or less when tested in accordance with ASTM D711.

M.07.22—Epoxy Resin Pavement Markings:

General Requirements:

Identification: Each container must be labeled with the following information: Name and address of manufacturer, production batch number, date of manufacture, grade name and/or identification number, type of material, number of gallons, Contract number, directions for mixing and application.

Certification: The Contractor shall provide a Material Certificate in accordance with 1.06.07 or 1.20- 1.06.07 for each portion of a batch or lot delivered to the Site.

Detailed Requirements:

(a) **Epoxy Resin Material:** The material shall be composed of epoxy resins and pigments only. The white and the yellow epoxy resin materials shall be composed of approved materials and be lead- and chromium-free.

(b) Composition:

WHITE (percent by weight)	YELLOW (percent by weight)
20% ± 2% Titanium Dioxide (ASTM D476 Type III)	
80% ± 2% Epoxy Resins	75% ± 2% Epoxy Resins

(c) **Color:** The white material shall be **in accordance with the MUTCD**, when the material is placed in a type EH weatherometer for a period of 500 hours and weathered according to ASTM G152. The yellow material shall be **in accordance with the MUTCD**.

(d) **Adhesion Capabilities:** When the adhesion of the material to Portland cement concrete is tested in accordance with AASHTO T 237, the failure of the system must take place in the concrete.

(e) **Abrasion Resistance:** When the abrasion resistance of the material is tested according to ASTM D4060 with a CS-17 wheel under a load of 1000 grams for 1000 cycles, the wear index shall be no greater than 82.

(f) **Hardness:** The Type D durometer hardness of the material shall be not less than 75 nor more than 90 when tested in accordance with ASTM D2240 after the material has cured for 72 hours at 73°F ± 3.5°F.

(g) **Tensile Strength:** The tensile strength of the material, when tested in accordance with ASTM D638, shall not be less than 6,000 psi after 72 hours cure at 73°F ± 3.5°F.

(h) **Compressive Strength:** The compressive strength of the material, when tested in accordance with ASTM D695, shall not be less than 12,000 psi after 72 hours cure at 73°F ± 3.5°F.

(i) **Shelf Life:** The individual components shall not require mixing prior to use when stored for a period of 12 months.

(j) **Glass Beads:** The glass beads shall meet the requirements of M.07.30.

M.07.23—Vacant

M.07.24—Preformed Black-Line Mask Pavement-Marking Tape:

General Requirements: The preformed, patterned black-line mask pavement-marking tape shall consist of a matte black, non-reflective tape in widths or sizes sufficiently large to mask the existing markings which are to be temporarily covered.

The patterned masking tape shall be pre-coated with a pressure sensitive adhesive and shall be capable of being adhered to existing markings, on bituminous concrete pavement or Portland cement concrete in accordance with the manufacturer's instructions without the use of heat, solvents or other additional

adhesives, and shall be immediately ready for traffic use after application. The Contractor shall identify equipment necessary for proper application and removal, and make recommendations for application that will assure effective product performance.

The preformed, patterned black-line masking pavement-marking tape shall be suitable for use for 1 year after the date of receipt when stored in accordance with the manufacturer's recommendations.

Detailed Requirements:

- (a) **Composition:** The non-reflective, patterned black-line mask pavement-marking tape shall not contain metallic foil and shall consist of a mixture of high quality polymeric materials, pigments and inorganic fillers distributed throughout its base cross-sectional area, with a matte black non-reflective top layer. The patterned surface shall have a minimum of 20% of the surface area raised and coated with non-skid particles. The channels between the raised areas shall be substantially free of particles. The film shall be pre-coated with a pressure sensitive adhesive. A non-metallic medium shall be incorporated to facilitate removal.
- (b) **Skid Resistance:** The surface of the patterned, non-reflective black-line mask pavement-marking tape shall provide an initial average skid resistance value of 60 British Pendulum Number when tested in accordance with ASTM E303.
- (c) **Thickness:** The patterned material, without adhesive, shall have a minimum thickness of 0.065 inch at the thickest portion of the patterned cross-section and a minimum thickness of 0.02 inch at the thinnest portion of the cross-section.
- (d) **Adhesion:** The black-line mask pavement-marking tape shall adhere to the pavement and existing pavement markings under climatic and traffic conditions normally encountered in the construction work zone.
- (e) **Removability:** The black-line mask pavement-marking tape shall be capable of being removed after its intended use without the use of heat, solvents, grinding, sand or water blasting.

M.07.25—Vacant

M.07.30—Glass Beads: The glass beads shall meet the requirements of AASHTO M 247, Type 1 or 4, depending on application.

**SECTION M.14
PRESTRESSED CONCRETE MEMBERS**

Replace Section M.14 in its entirety with the following:

**SECTION M.14
PREFABRICATED CONCRETE MEMBERS**

M.14.01—Materials

M.14.01—Materials:

- Concrete:** The concrete for the members shall be air-entrained concrete composed of Portland cement, fine and coarse aggregates, admixtures and water. The concrete shall meet the properties listed in Table M.14-1 for the class designated on the plans.

Table M.14-1 Precast/Prestressed Portland Cement Concrete Mix Classes

Class	28-day Strength (psi)	Resistivity (kΩ-cm) at 56 days AASHTO T 358	Entrained Air
PRC04060	4,000	NA	6.0 +/- 1.5%
PRC04062	4,000	29	6.0 +/- 1.5%
PRC05060	5,000	NA	5.0 +/- 1.5%
PRC05062	5,000	29	5.0 +/- 1.5%
PRC06060	6,000	NA	5.0 +/- 1.5%
PRC06062	6,000	29	5.0 +/- 1.5%
PRC08060	8,000	NA	5.0 +/- 1.5%
PRC08062	8,000	29	5.0 +/- 1.5%
PRC10060	10,000	NA	4.0 +/- 1.5%
PRC10062	10,000	29	4.0 +/- 1.5%

PRCXXXYZ() PRC=Precast/Prestressed Concrete

XXX = 28-day strength (x100 psi) Y=Stone size (No. 6 = No. 67)

Z= (0=no resistivity requirement, 2=resistivity requirement)

- Coarse and Fine Aggregate** shall meet the requirements of M.01.
 - Water and all Admixtures** shall meet the requirements of M.03.01.
 - Portland Cement** shall meet the requirements of M.03.01, except that mixes using Type III or Type IIIA Portland cement will be considered standard. Mixes using other cement types will be considered non-standard.
- Prestressing Steel:** Unless otherwise specified, prestressing elements shall be uncoated, high tensile strength, seven-wire strand meeting the requirements of AASHTO M 203.
 - Reinforcing Steel and Tie Wire:** All deformed bars, stirrups, dowels, threaded dowels and tie wire shall meet the requirements of 6.02 and M.06.01-1.
 - Lifting Hooks, Pipe Sleeves, Base Protective Plates, Threaded Inserts:** These components shall be as indicated on the Shop and Working Drawings.
 - Transverse Tie Strands** shall be of the size and type noted on the plans, coated with a corrosion-resistant mastic and inserted into a polyethylene tube.
 - Non Shrink Grout** shall meet the requirements of M.03.05.
 - Void Forms:** Internal voids may be formed by the use of void forms especially made for this purpose. These void forms must be of substantial construction and be adequately waterproofed in order to maintain their shape during the fabrication process. These void forms shall be as indicated on the Shop and Working Drawings.
 - Metal Tie Wires, Clips, Bar supports:** Unless otherwise noted on the plans, all wires, clips, chair

and bar supports, used during the fabrication and placement of the reinforcing bars shall be of the same type as the reinforcing steel.

9. Penetrating Sealer Protective Compound: The penetrating sealer shall conform to M.03.09.

**SECTION M.15
HIGHWAY ILLUMINATION**

In the list of Articles, change the title of Article M.15.16 as follows:

| **M.15.16—Vacant**

Replace Article M.15.16 with the following:

| **M.15.16—Vacant**

SECTION M.16
TRAFFIC CONTROL SIGNALS

In the list of Articles, change the title of Articles M.16.08 and M.16.13 as follows:

M.16.08—Pedestrian Pushbutton
M.16.13—Vacant

Replace Subarticle M.16.06-9 in its entirety as follows:

M.16.06—Traffic Signals:

9. Painting: All surfaces of the signal housing, housing door, visors, inside and out, the back surface of the backplate and all brackets and hardware shall be cleaned and coated with a Primer conforming to FS TT-P-1757. The surfaces shall then be finished with 3 coats of infrared oven baked paint applied by the manufacturer, before assembly.

First Coat: The primer shall be iron oxide baking primer and shall meet or exceed the requirements of FS TT-P-664.

Second Coat: Shall be light gray exterior baking enamel and shall comply with FS TT-E-489, either No. 16251, No. 16314, or No. 16376 Gray.

Third Coat: Shall be exterior baked enamel and shall comply with FS A-A-2962.

The housing, housing door, the back surface of the backplate, and all brackets and hardware shall be painted black by the manufacturer. The color shall be Aerospace Material Specification – Standard 595 (AMS-STD-595) Color No. 17038.

At intersections at Merritt Parkway interchanges, the housing, housing door, the back surface of the backplate, and all brackets and hardware shall be painted black by the manufacturer. The color shall be AMS-STD-595 Color No. 14056.

The outside of the visors shall have a dull black finish that meets FS TT-E-527.

The inside of the visors and front surface of the backplate per the MUTCD shall have a dull black finish to minimize light reflection and to increase contrast between the signal indication and its background. The dull black finish shall meet FS TT-E-527.

Replace Subarticle M.16.07-C-2 in its entirety with the following:

M.16.07—Pedestrian Signal:

2. LED: The optical unit shall consist of multiple LED light sources and a regulated power supply assembled as a sealed unit. The diodes shall be arranged to display a full-hand symbol side by side with a full pedestrian symbol. The optical unit shall fit into a standard pedestrian signal housing so that it may be installed into an existing incandescent pedestrian signal. The LED optical unit shall be capable of maintaining message symbol integrity despite any partial loss of LEDs. The beam color shall match that of the incandescent message: walking symbol - lunar white, hand - Portland orange. The beam pattern and intensity shall meet ITE specifications. The intensity may not degrade by more than 10% per annum. The optical unit shall be warranted by the manufacturer for a period of 5 years.

Electrical Requirements:

- Input Voltage: 89 VAC to 135 VAC
- Wattage: 15 Watts
- Input Impedance at 60 Hz must satisfy all conflict monitor requirements.
- A regulated power supply shall be engineered to protect the LEDs from electrical surges and transient voltages.

Replace Subarticles M.16.07-E and M.16.07-F with the following:

E. Hardware: All exposed screws and fasteners shall be stainless steel. All internal screws, fasteners and metal parts shall be stainless steel, non-corrosible materials; or cadmium-plated ferrous materials.

F. Painting: All surfaces of the signal housing, door, all brackets and hardware, and visors, inside and out, shall be finished with 3 coats of infrared-oven- baked paint applied by the manufacturer before

assembly. All brackets and hardware shall be painted **black** by the manufacturer. The color shall be **AMS-STD-595 Color No. 17038**.

First Coat: The primer shall be iron oxide baking primer and shall meet or exceed the requirements of FS TT-P-645.

Second Coat: Shall be light gray exterior baking enamel and shall meet the requirements of FS TT-E-489, No. 16251, No. 16314 or No. 16376 gray.

Third Coat: Shall be exterior-baking enamel and shall meet the requirements of FS A-A-2962.

The housing, housing door, outside of the visor, and all brackets and hardware shall be painted black by the manufacturer. The color shall be **AMS-STD-595 Color No. 17038**.

At intersections at Merritt Parkway interchanges, the housing, housing door, outside of visor, and all brackets and hardware shall be painted dark green by the manufacturer. The color shall be **AMS-STD-595 Color No. 14056**.

The inside of the visor shall have a dull black finish to minimize light reflection and to increase contrast between the signal indication and its background. The dull black finish shall meet FS TT-E-527.

In Article M.16.08, replace the "Painting" Subarticle with the following:

M.16.08—Pedestrian Pushbutton:

Painting: All surfaces of the unit shall be finished with 3 coats of infrared oven-baked paint **applied by the manufacturer**, before assembly.

First Coat: Primer, shall be **iron** oxide baking primer and shall meet **or** exceed performance specification of FS TT-P-664.

Second Coat: Gray Enamel, shall be lusterless and shall comply with FS TT-E-527.

Third Coat: **Black** Enamel, shall be **BLACK** exterior-baking enamel and shall meet the requirements of FS A-A 2962. The color shall be **AMS-STD-595 Color No. 17038**. **At intersections at Merritt Parkway interchanges, the color shall be AMS-STD-595 Color No. 14062**.

Replace Article M.16.13 with the following:

M.16.13—Vacant

In Article M.16.09, replace the "Painting" Subarticle with the following:

M.16.09—Controllers:

Painting: All outside surfaces of the cabinet and door shall be finished with 3 coats of infrared oven-baked paint before assembly.

First Coat: The primer shall be **iron** oxide baking primer and shall meet or exceed FS TT-P-636.

Second and Third Coats: The second and third coats will be aluminum paint meeting the requirements of FS TT-P-320, and Federal Test Method Standard 141. The color shall be **AMS-STD-595 Color No. 17178**.

Replace the last paragraph in Article M.16.17 with the following:

M.16.17—Illuminated Signs:

A weatherproof housing of the dimensions specified on the plans shall be provided to enclose the fiber optic module assembly with bifurcated output fiber bundles, color filters, light sources and transformers. The sign housing frame shall be manufactured from extruded aluminum, 6061-T6, ASTM B221. This assembly shall be provided with a hinged access door. The hinge shall be stainless steel piano type hinge mounted on the left side of the door. All external hardware shall be stainless steel, internal hardware shall be corrosion resistant. The housing shall have a minimum of four 1 inch diameter drainage holes. The entire front face of the sign shall be protected by a 1/8 inch thick sheet of clear polycarbonate mounted in the door frame. The housing shall be Federal **Black** according to **AMS-STD-595 Color No. 17038** and the aluminum front panel shall be flat black according to **AMS-STD-595 Color No. 37031** unless otherwise specified on the plans. **At intersections at Merritt Parkway interchanges, the housing shall be AMS-STD-595 Color No. 14062**. The complete sign assembly shall not weigh more than 150 pounds.

The legend displayed for an "Overhead Illuminated 'Stop Ahead' Sign" shall consist of letters 12 inches high and approximately 9 inches wide formed by fiber optic bundles spaced approximately 1 1/2 inches apart. The sign shall be supplied completely assembled and ready to be checked out.