



**03395**



**03396**

# Virtual Public Information Meeting

State Project No. 0028-0208

Bridge Nos. 03395 & 03396 / Route 2 WB & EB over Route 85

Town of Colchester

# Project 28-208 Purpose & Need

**The purpose of the project is to address structural deficiencies associated with the satisfactory condition of each of the decks, the fair condition of the steel beams and diaphragms of Bridge No. 03395 and the poor condition of the steel beams and diaphragms of Bridge No. 03396.**

**This work is being done to preserve bridge life expectancy while minimizing impacts to Route 2 traffic and Route 85 traffic, in order to get or maintain the bridges in a State of Good Repair.**

**The proposed rehabilitation includes new metallized steel beams with composite concrete decks, continuous decks (where applicable), bearing replacement and substructure repairs.**



Bridge No.03395



Bridge No. 03396

# Project 28-208 Location

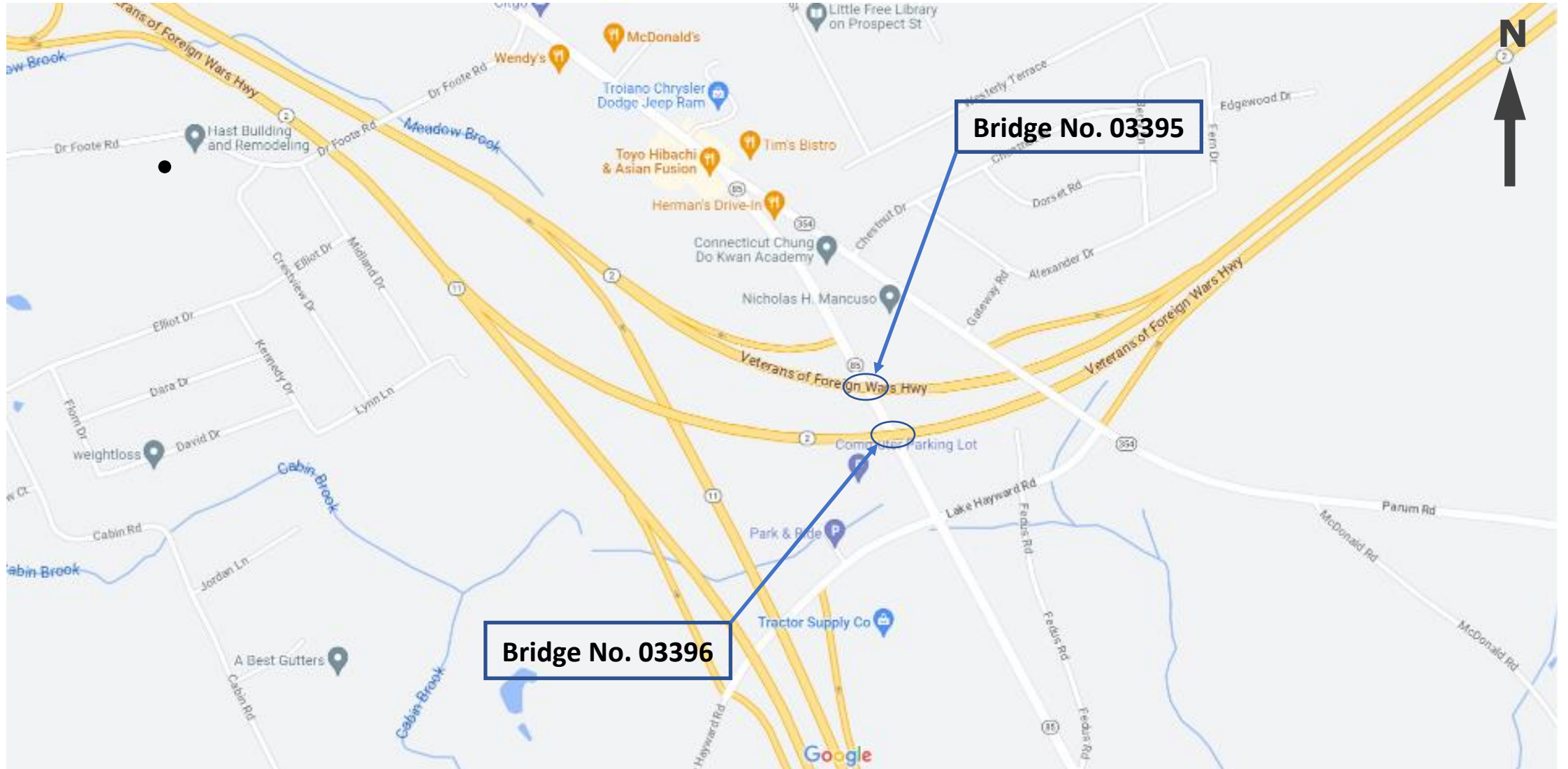

# Project 28-208 Location



# Aerial View (Bridge No. 03395)



# Aerial View (Bridge No. 03396)



# Existing Bridge Overview (Bridge No. 03395)

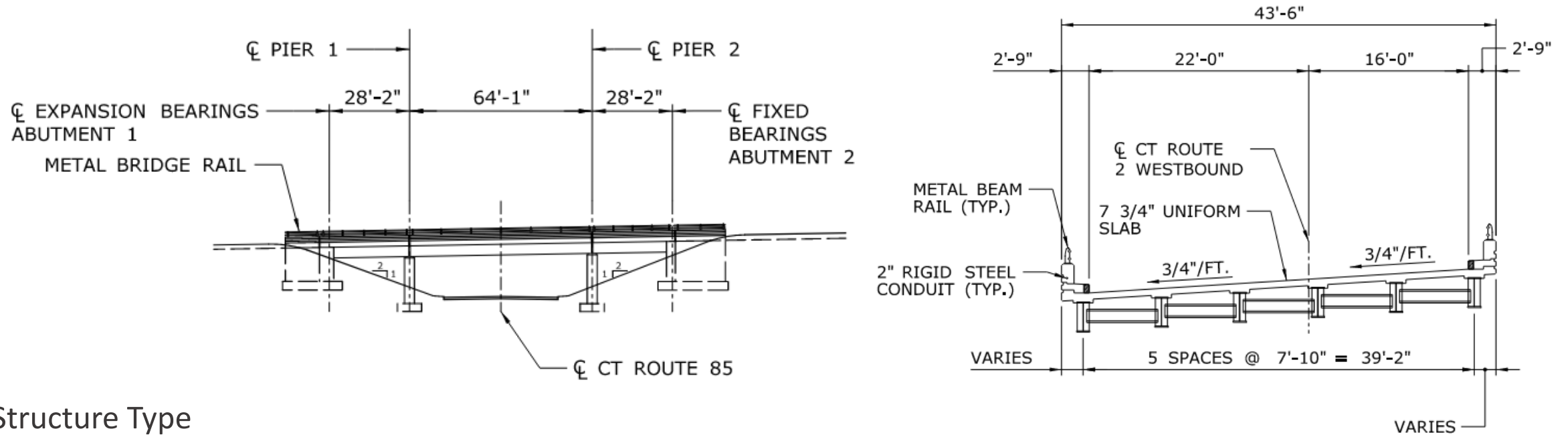

## Structure Type

- Curved Structure: Rolled beams are laid parallel to BL tangent in Spans 2 & 3, skewed in Span 1
- 3-Span Bridge: Spans 1, 2 & 3 simply supported; Spans 1 & 3 non-composite; Span 2 composite and coverplated
- Year Constructed: 1966
- Dimensions: 124' overall length, 38'-0" curb-to-curb width
- Steel rolled beams support 7-3/4" c.i.p. reinforced concrete deck slab with membrane waterproofing and overlay
- Minimum vertical clearance over Rte. 85 is 14'-3" (posted at 13'-11")

# Existing Bridge Overview (Bridge No. 03395)

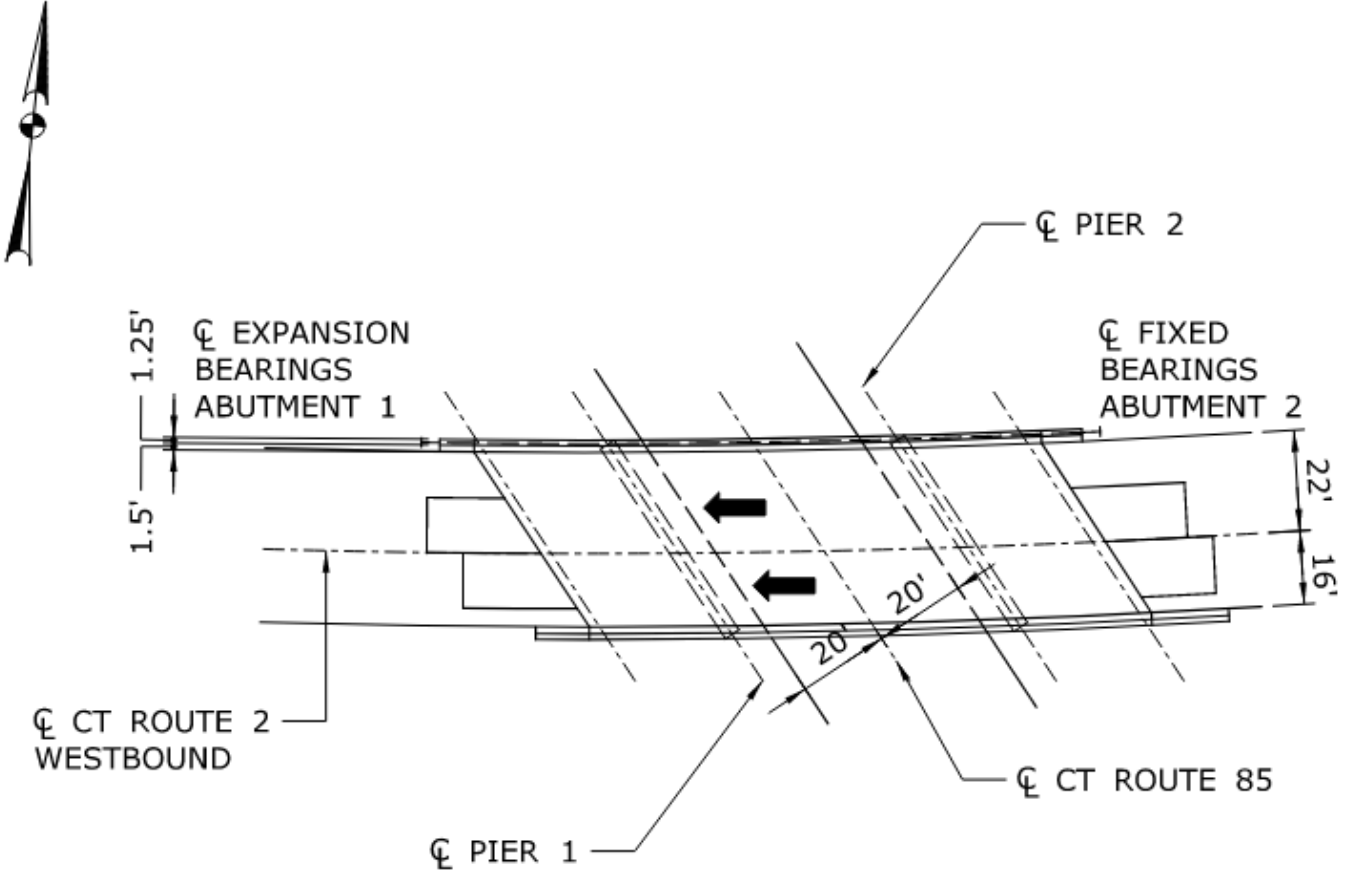



# Existing Bridge Overview (Bridge No. 03396)

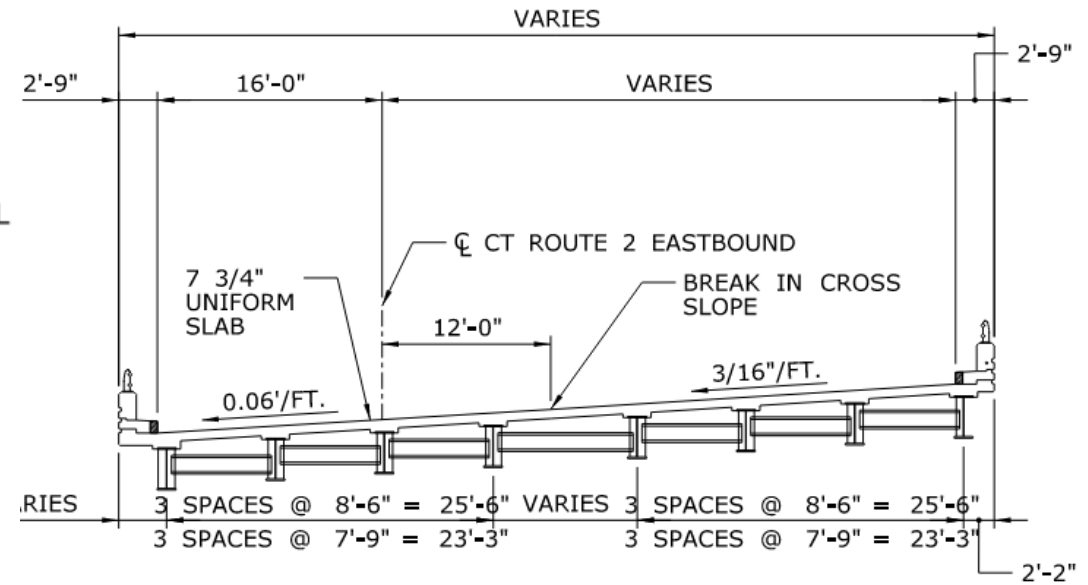
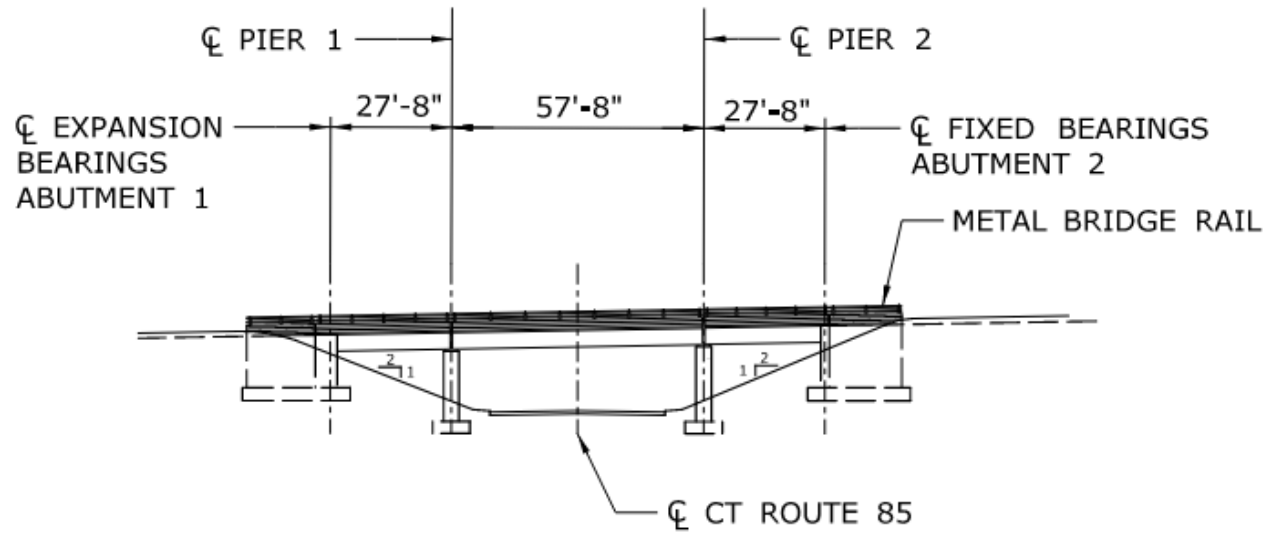

## Structure Type

- Curved Structure: North rolled beams are laid parallel to BL tangent, south rolled beams are laid parallel to south fascia
- 3-Span Bridge: Spans 1, 2 & 3 simply supported; Spans 1 & 3 non-composite; Span 2 composite and coverplated
- Year Constructed: 1966
- Dimensions: 117' overall length, 57'-7" curb-to-curb width (max.), 53'-3" curb-to-curb width (min.)
- Steel rolled beams support 7-3/4" c.i.p. reinforced concrete deck slab with membrane waterproofing and overlay
- Minimum vertical clearance over Rte. 85 is 14'-8" (vertical clearance is not posted)

# Existing Bridge Overview (Bridge No. 03396)

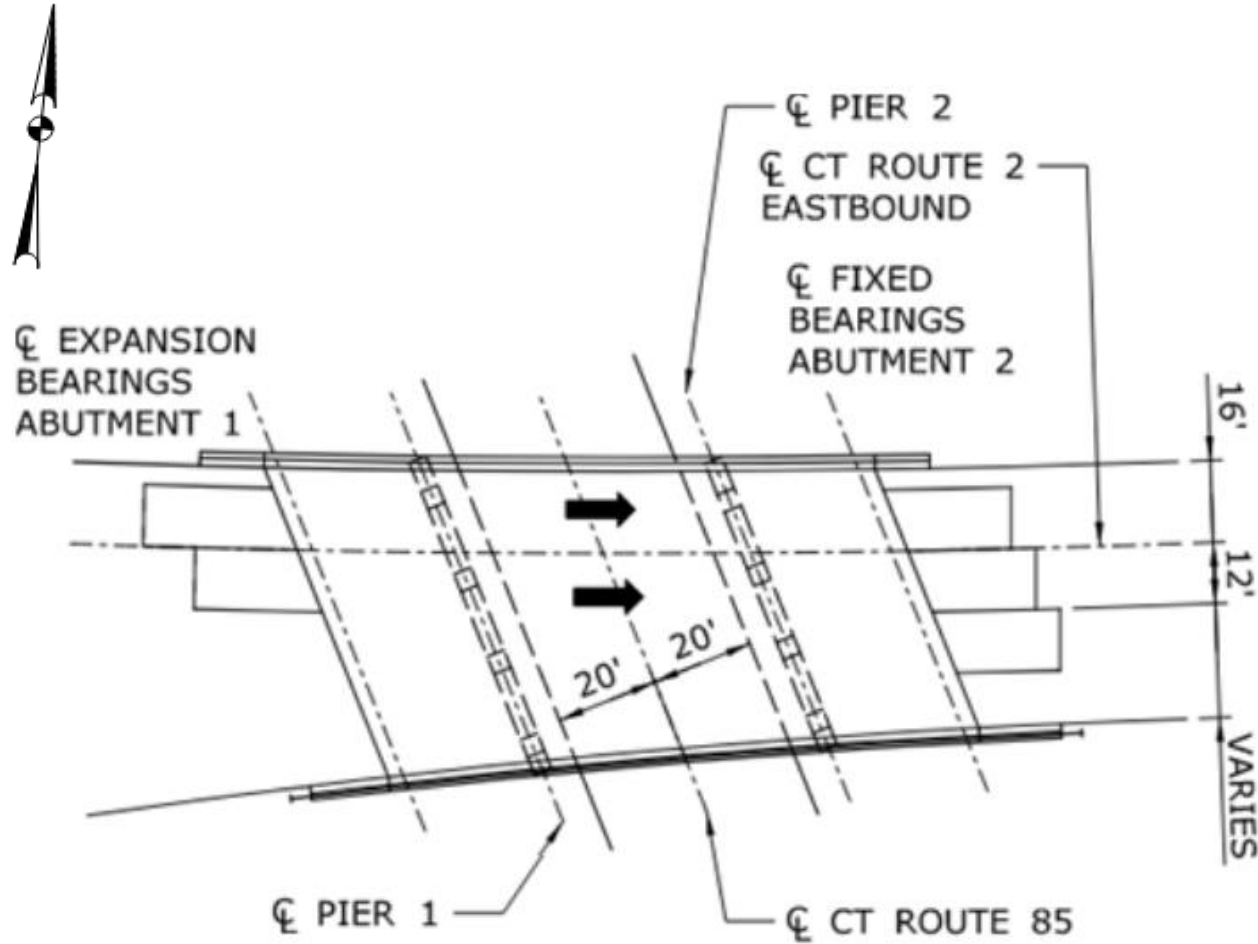

# Project 28-208 Scope of Work

## Superstructure Replacement and Minor Substructure Repairs:

- Install maintenance and protection of traffic controls along Route 2
- Install temporary traffic signals on Route 85
- Remove approach roadway pavement
- Remove approach slabs
- Remove overlay and existing concrete decks
- Remove existing steel beams and bearings
- Repair beam seats and install new elastomeric bearings
- Erect new metallized steel beams
- Place new approach slabs
- Place new composite, concrete decks and membrane waterproofing
- Pave approach roadways and install bituminous overlay on bridges
- Install guide rail
- Repair existing substructures



# Maintenance & Protection of Traffic – Stage 1



## Maintenance and Protection of Traffic

- Route 2 traffic can be staged with half-width phased construction to maintain one lane of traffic on each bridge at all times
- Superstructure replacement and substructure repairs will affect Route 85 travel-ways under the bridges; lane and shoulder closures with alternating traffic can be used to stage the work
- A detour route for Rte. 85 traffic is available, but is not necessary

# Maintenance & Protection of Traffic – Stage 2



## Maintenance and Protection of Traffic

- Route 2 traffic can be staged with half-width phased construction to maintain one lane of traffic on each bridge at all times
- Superstructure replacement and substructure repairs will affect Route 85 travel-ways under the bridges; lane and shoulder closures with alternating traffic can be used to stage the work
- A detour route for Rte. 85 traffic is available, but is not necessary

# Project 28-208 Schedule

- Final Design Plans: 05/28/2025
- Advertising: 08/06/2025
- Notice to Proceed: 04/01/2026



- Anticipated Construction Duration:  
April 2026 – November 2027
- Estimated Project Cost: \$14,500,00  
(80% Federal Funds/20% State Funds)